



Presentation example PME7



Presentation example LME7

## PME73.830Ax

## Program module for burner control LME73.000Ax

### User Documentation

#### Application:

- 1-stage or modulating, direct or pilot ignited forced draft burners
- Integrated actuator control via 3-position controller or analog signal (feedback potentiometer in the actuator required)
- Integrated valve proving (can be parameterized)
- E.g. for burners to EN 676

The PME7 and this User Documentation are intended for use by OEMs which integrate the LME7 with PME7 in their products.



#### Note!

This documentation is only valid together with LME7 Basic Documentation (P7105)!

# Contents

<b>1</b>	<b>Supplementary documentation .....</b>	<b>3</b>
<b>2</b>	<b>Warning notes .....</b>	<b>4</b>
<b>3</b>	<b>Typographical conventions .....</b>	<b>4</b>
<b>4</b>	<b>Program sequence PME73.830Ax .....</b>	<b>5</b>
<b>5</b>	<b>List of phase display .....</b>	<b>6</b>
<b>6</b>	<b>Fuel trains (examples) .....</b>	<b>7</b>
6.1	Gas direct ignition (G), 1-stage .....	7
6.2	Gas pilot ignition 1 (Gp1/1), 1-stage .....	7
6.3	Gas pilot ignition 1 (Gp1/2), 1-stage, with valve proving.....	8
6.4	Gas direct ignition 1 (Gp1/2), 1-stage, with valve proving .....	8
<b>7</b>	<b>Gas valve proving .....</b>	<b>9</b>
<b>8</b>	<b>Input gas pressure switch-min .....</b>	<b>11</b>
<b>9</b>	<b>Connection diagram for LME73.000Ax with SQM4.....</b>	<b>12</b>
<b>10</b>	<b>Time table and settings .....</b>	<b>13</b>
<b>11</b>	<b>Inputs and outputs / internal connection diagram .....</b>	<b>15</b>
<b>12</b>	<b>Parameter list (AZL2).....</b>	<b>16</b>
<b>13</b>	<b>Error code list.....</b>	<b>19</b>
<b>14</b>	<b>Legend .....</b>	<b>21</b>
<b>15</b>	<b>List of figures .....</b>	<b>22</b>

# 1 Supplementary documentation

Product type	Designation	Type of documentation	Documentation number
LME	Burner control	Environmental Product Declaration	E7105 *)
PME	Program module	Environmental Product Declaration	E7105.1 *)
LME7	Burner control	Data Sheet	N7105
LME	Burner control	Product Range Overview	Q7101
LME7	Burner control	Basic Documentation	P7105

\*) On request only



## Note

This document only refers to the product type – not the *product designation*. See the table below for details.

Product type	Product designation
ACS410	PC software
AZL2	Display and operating unit
ION	Ionization probe
LME7	Burner control
QRA	UV flame detector
QRB	Photo resistive detector
QRC	Blue-flame detector
PME7	Program module
SQM4	Actuator

## 2 Warning notes



### Warning!

The safety, warning and technical notes given in the Basic Documentation on the LME7 (P7105) apply fully to the present document also!

To avoid injury to persons, damage to property or the environment, the following warning notes must be observed!

The LME7 are safety devices! Do not open, interfere with or modify the unit. Siemens does not assume responsibility for damage resulting from unauthorized interference!



### Warning!

On the OEM access level of the LME7, it is possible to make parameter settings that differ from application standards. When setting the parameters, it is important to ensure that the application will run safely in accordance with legal requirements. Failure to observe this information poses a risk of damaging the safety functions.



### Warning!

**Risk of damage to the switching contacts!**

If the external primary fuse (Si) is blown due to overload or short-circuit at the terminals, the LME7 must be replaced.

## 3 Typographical conventions

### Safety notes

This User Documentation contains notes which must be observed to ensure your personal safety and to protect the product and the connected equipment. The instructions and notes are highlighted by warning triangles-or a hand symbol and are presented as follows, depending on the hazard level:



### Warning

means that death, severe personal injury or substantial damage to property **can** occur if adequate precautionary measures are not taken



### Note

draws your attention to **important information** on the product, on product handling, or to a special part of the documentation

### Qualified personnel

Only **qualified staff** are allowed to install and operate the equipment. Qualified staff in the context of the safety-related notes contained in this document are persons who are authorized to commission, ground and tag devices, systems and electrical circuits in compliance with established safety practices and standards.

### Correct use

*Note the following:*

The device may only be used on the applications described in the technical documentation and only in connection with devices or components from other suppliers that have been approved or recommended by Siemens.

The product can only function correctly and safely if shipped, stored, set up and installed correctly, and operated and maintained as specified.

# 4 Program sequence PME73.830Ax

→ For fuel trains G, Gp1/1 and Gp1/2

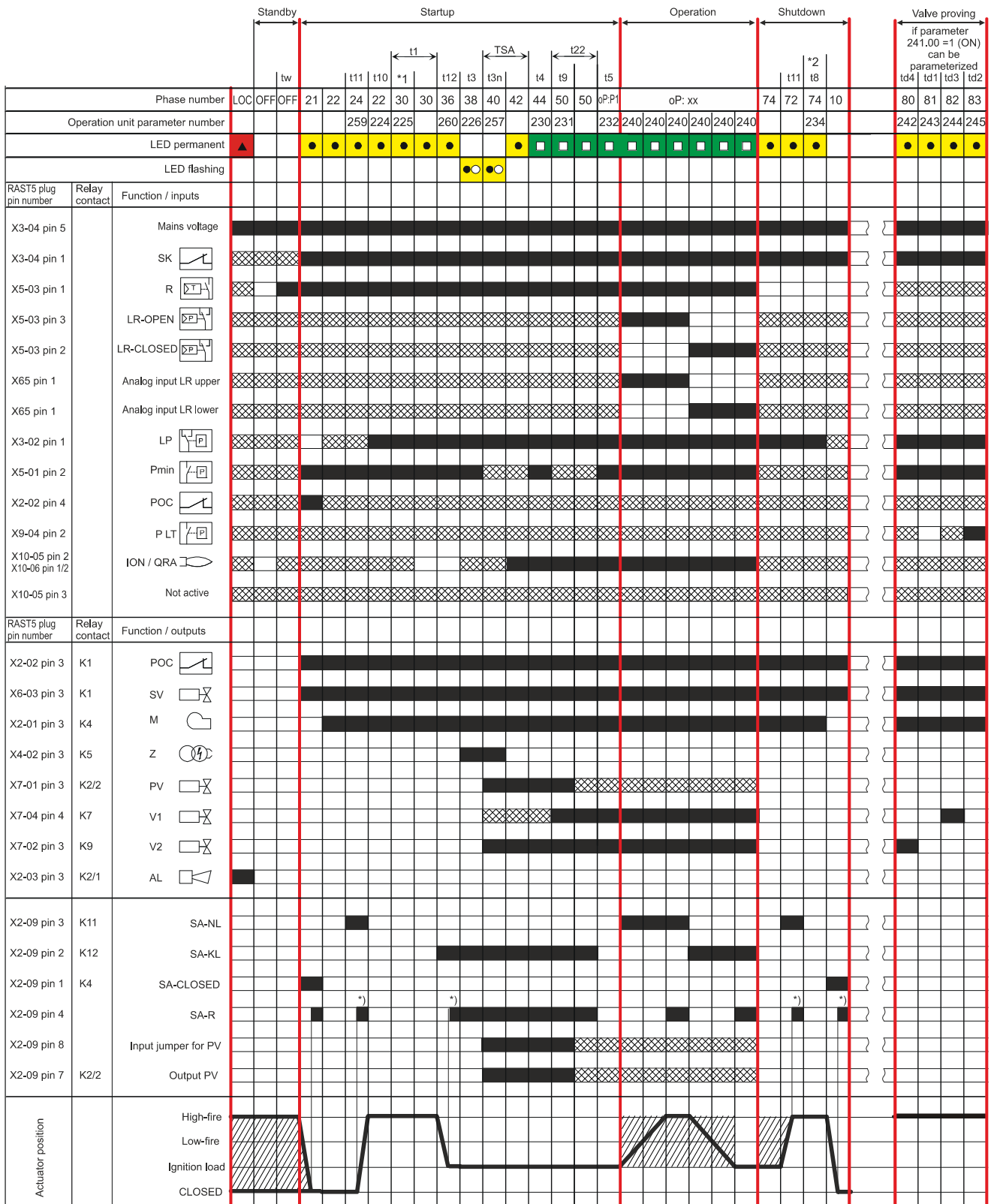

7105d76e/0312

Figure 1: Program sequence for fuel trains G, Gp1/1, and Gp1/2

\*) During the actuator's running phases, the actuator's feedback signal must first be OFF, then ON

## 5 List of phase display

Phase number of display		LED	Function
7-segment	AZL2		
LOC	LOC	Red	Lockout phase
<b>Standby</b>			
OFF	OFF	OFF	Standby, waiting for heat request
P08	Ph08	OFF	Power ON/test phase (e.g. detector test)
<b>Startup</b>			
P21	Ph21	Yellow	Safety valve ON, air pressure switch in no-load position Test if POC closed (timeout/lockout after 5 seconds) Actuator travels in CLOSED position (timeout)
P22	Ph22	Yellow	Part 1: Fan motor ON Part 2: Specified time air pressure switch Message (timeout), stabilization air pressure switch
P24	Ph24	Yellow	Actuator travels in prepurge position (timeout)
P30	Ph30	Yellow	Part 1: Prepurge time without extraneous light test *1 Part 2: Prepurging with extraneous light test (2.1 seconds)
P36	Ph36	Yellow	Actuator travels in ignition load position (timeout)
P38	Ph38	Yellow	Preignition time
P40	Ph40	Yellow flashing	Postignition time
P42	Ph42	Green	Flame detection
P44	Ph44	Green	Interval: End of safety time and fuel valve V1 ON
<b>Operation</b>			
xx	oP:xx	Green	Operation (modulation), display of the actual value in percent (%)
oP1	oP:P1	Green	Interval until load controller release
<b>Shutdown</b>			
P10	Ph10	OFF	Home run
P72	Ph72	Yellow	Actuator travels in postpurge position (timeout)
P74	Ph74	Yellow	Postpurge time *2
<b>Valve proving</b>			
P80	Ph80	Yellow	Test space is evacuated
P81	Ph81	Yellow	Test time atmospheric pressure
P82	Ph82	Yellow	Test space is filled
P83	Ph83	Yellow	Test time gas pressure
<b>Safety shutdown phases</b>			
P01	Ph01	Yellow / red	Under voltage / over voltage
P02	Ph02	Yellow	Safety shutdown (e.g. open safety loop) → Non-volatile lockout
P04	Ph04	Green / red	Extraneous light in standby
P90	Ph90	Yellow	Gas pressure switch-min open → safety shutdown and start prevention

\*1 Valve proving during prepurging, if  
 - parameter 241.00 = 1 and parameter 241.02 = 1 or  
 - parameter 241.00 = 1 and parameter 241.01 = 0 or  
 - parameter 234 (postpurge time) = 0 seconds

\*2 Valve proving during postpurging, if  
 - parameter 241.00 = 1 and parameter 241.02 = 1 or  
 - parameter 241.00 = 1 and parameter 241.01 = 1 and  
 - parameter 234 (postpurge time) >0 seconds

# 6 Fuel trains (examples)

## 6.1 Gas direct ignition (G), 1-stage

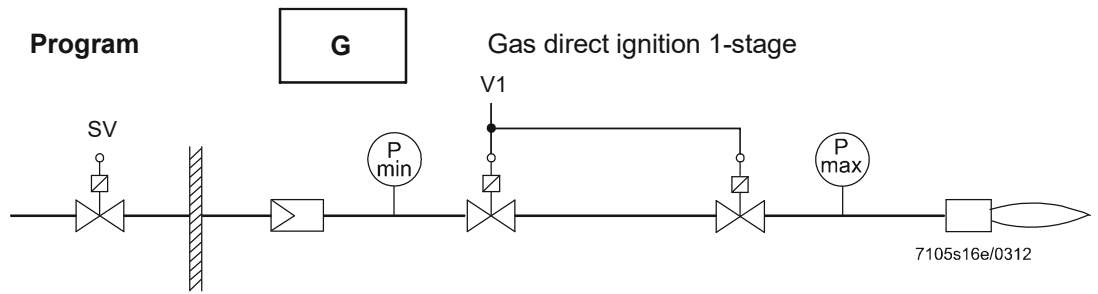
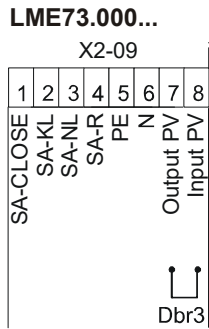
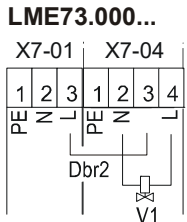

Figure 2: Fuel train gas direct ignition (G), 1-stage

## 6.2 Gas pilot ignition 1 (Gp1/1), 1-stage

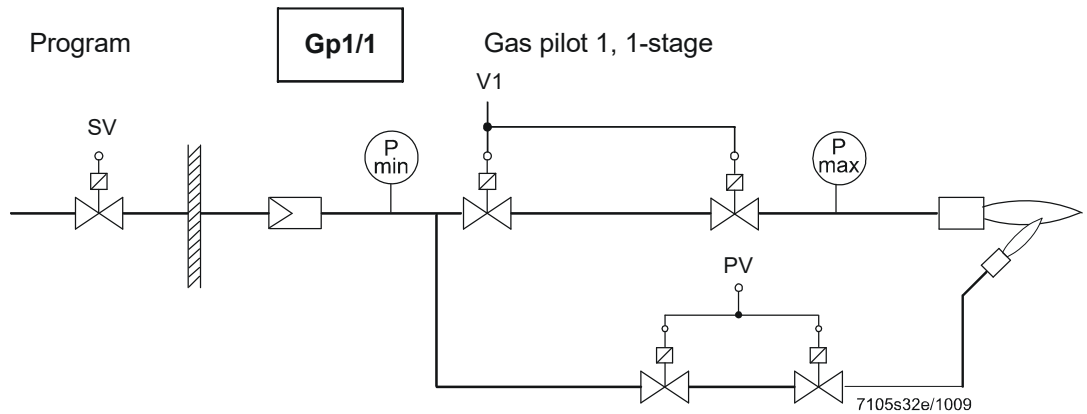
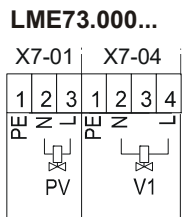

Figure 3: Fuel train gas pilot ignition 1 (Gp1/1), 1-stage

### 6.3 Gas pilot ignition 1 (Gp1/2), 1-stage, with valve proving

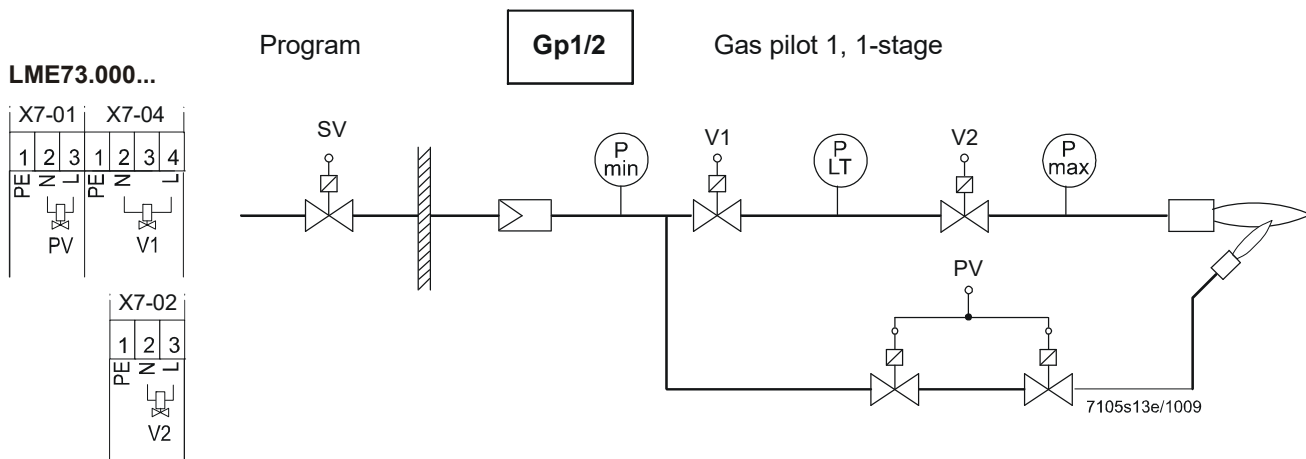

Figure 4: Fuel train gas pilot ignition 1 (Gp1/2), 1-stage, with valve proving

### 6.4 Gas direct ignition 1 (Gp1/2), 1-stage, with valve proving

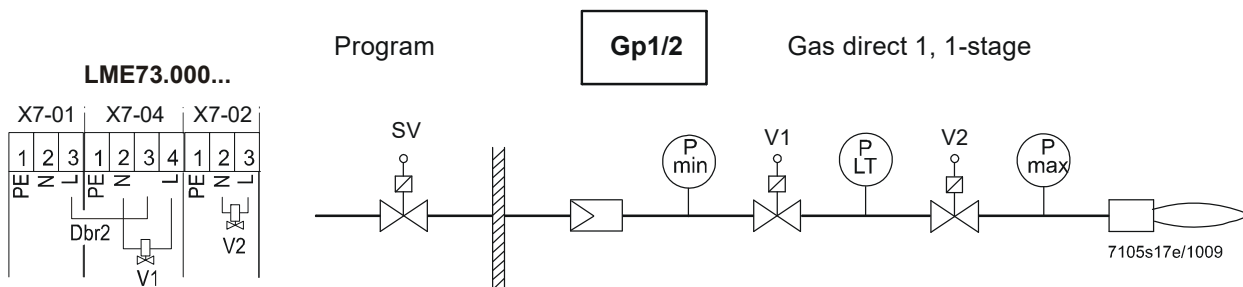

Figure 5: Fuel train gas direct ignition 1 (Gp1/2), 1-stage, with valve proving



**Note:**  
 When valve proving is activated (e.g. on shutdown), the load on the valve's terminals is restricted.

Fuel valve V1 terminal X7-04 pin 4/fuel valve V2 terminal X7-02 pin 3

- |                 |                     |                     |
|-----------------|---------------------|---------------------|
| • Rated voltage | AC 120 V            | AC 230 V            |
|                 | 50/60 Hz            | 50/60 Hz            |
| • Rated current | 1 A                 | 1 A                 |
| • Power factor  | $\cos\varphi > 0.4$ | $\cos\varphi > 0.4$ |

If the terminal load is not reduced (max. rated current 2 A,  $\cos\varphi > 0.4$ ), the design lifetime will be reached after about 100,000 burner startup cycles!



# 7 Gas valve proving

Valve proving is dependent on parameter 241. Valve proving is employed to detect leaking gas valves and, if necessary, to prevent the gas valves from opening or ignition from being switched on. A non-volatile lockout will be initiated in these cases.

## Valve proving with separate pressure switch

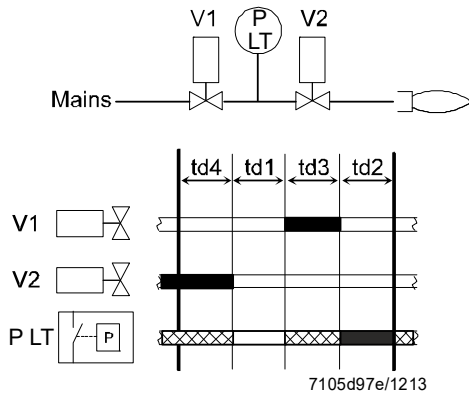

Fig. 6: Valve proving with separate pressure switch

Step 1: td4 – test space evacuating.

Gas valve on the burner side is opened to bring the test space to atmospheric pressure.

Step 2: td1 – test time atmospheric pressure.

When the gas valve has closed, the gas pressure in the test space must not exceed a certain level.



Step 3: td3 – test space filling.

Gas valve on the mains side opens to fill the test space.

Step 4: td2 – test time gas pressure.

When the gas valve has closed, the gas pressure in the test space must not drop below a certain level.

### Legend

td1	Test time atmospheric pressure
td2	Test time gas pressure
td3	Test space filling
td4	Test space evacuating
Vx	Fuel valve
P LT	Pressure switch valve proving
	Input/output signal 1 (ON)
	Input/output signal 0 (OFF)
	Permissible signal 1 (ON) or 0 (OFF)

Query logic of gas pressure switch for valve proving:

- Gas pressure present → pressure switch closed
- Gas pressure not present → pressure switch open

Valve proving can be parameterized to take place on startup, shutdown, or both.

Recommendation:

Perform valve proving on shutdown.

No.	Parameter
241.00	Valve proving 0 = OFF 1 = ON <sup>1)</sup>
242	Valve proving - test space evacuating
243	Valve proving - test time atmospheric pressure
244	Valve proving - test space filling
245	Valve proving - test time gas pressure

<sup>1)</sup> Valve proving during postpurging, if parameter 234 >0 (postpurge time) and parameter 241.01 = 1

## Program sequence with valve proving

During startup

Valve proving during startup is performed only after a reset from the lockout position, after power ON, and when parameter 234 = 0 seconds.

In that case, valve proving takes place at the same time as prepurging. This means that the prepurge time corresponds to at least the sum of all 4 valve proving parameters (242, 243, 244, and 245).

During shutdown

Valve proving during shutdown is performed only if the postpurge time >0 (parameter 234 >0). If no postpurge time is parameterized, valve proving takes place during startup when prepurging. During shutdown (heat request OFF), it is checked if parameter 241.00 = 1 (valve proving ON) and parameter 234 ≠ 0 seconds before the fuel valves close. This means that, first, fuel valve V1 is closed. Fuel valve V2 remains open, so that the remaining gas in the test space can be burned. The postpurge time runs at the same time as valve proving. This means that the postpurge time corresponds to at least the sum of all 4 valve proving parameters (242, 243, 244, and 245).

Prior to postpurging and valve proving, the actuator travels to the high-fire position.



### Warning!

**The OEM must set the evacuation, filling and test times for atmospheric or mains pressure on every plant in compliance with the requirements of EN 1643. If not observed, there is a risk of impairment of safety functions.**

It must be ensured that the 2 test times are correctly set. It is to be checked whether the gas required for the test may be fed into the combustion chamber (on the relevant application). The test times are safety-related. After a reset, unlock, and in the case of aborted or prevented valve proving, the LME7 will perform valve proving the next time it is started up (only when valve proving is activated). In the case of valve proving, prepurging is active during the startup phase, even if it has been deactivated.

Examples of aborted valve proving:

When the safety loop or the start prevention input for gas (containing pressure switch-min) opens during valve proving.

### Valve proving – calculation of leakage rate

$$t_{\text{Test}} = \frac{(P_G - P_W) \cdot V \cdot 3600}{P_{\text{atm}} \cdot Q_{\text{Leck}}}$$

Q <sub>Leck</sub>	in l/h	Leakage rate in liters per hour
P <sub>G</sub>	in mbar	<b>Overpressure</b> between the fuel valves at the beginning of the test phase
P <sub>W</sub>	in mbar	Overpressure set on the pressure switch (normally 50% of the gas inlet pressure)
P <sub>atm</sub>	in mbar	<b>Absolute air pressure</b> (1013 mbar normal pressure)
V	in l	Volume between the fuel valves (test volume) including valve volume and pilot path if present
t <sub>Test</sub>	in s	Test time

## 8 Input gas pressure switch-min

Behavior in the event gas pressure switch-min fails (terminal X5-01 pin 2 and pin 3)

If gas pressure switch-min fails, safety shutdown is triggered and startup prevented until gas pressure switch-min closes again. During start prevention, the yellow LED is lit and the safety circuit is active. The LME7 is in phase 90.

# 9 Connection diagram for LME73.000Ax with SQM4

Note:  
 The connection diagram shown is merely an example which must be verified in the individual case depending on the application!

**PME73.830Ax 1-stage modulating**  
**With/without pilot ignition**  
**With/without valve proving**

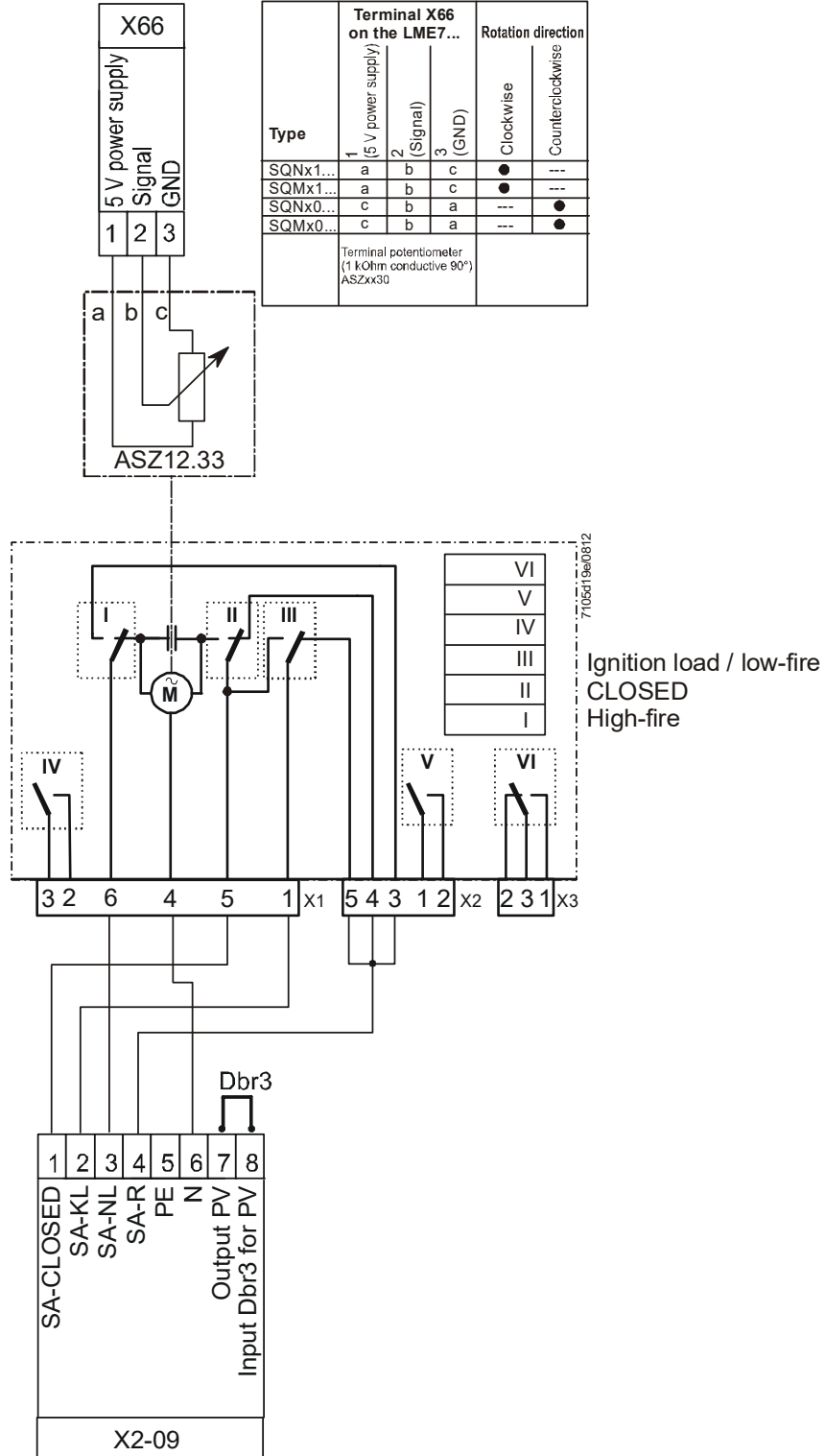

Figure 7: Connection diagram for LME73.000Ax with SQM4

# 10 Time table and settings

Type	Times in seconds																	
PME73.830Ax	tw	TSA max.	t1 P225 4) min.	t3 P226 min.	t3n P257 approx.	t4 P230 min.	t5 P232 min.	t8 P234 5) min.	t9 P231 approx.	t10 P224 approx.	t11 P259 approx.	t12 P260 approx.	t22	1)	2)	3)	td1 P243 td2 P245 min.	td3 P244 td4 P242 max.
Requirements	2.5	3	30	6	2,5	9	8.5	15	3	15	300	300	t9+1	---	---	---	10	3
Factory setting	---	t3n+0.45	29.106+2.1	6.174	2.205+0.3	9.408	8.82	19.404	2.646	13.818	300.762	300.762	---	---	---	---	10.29	2.646
Max.	2.5	14	1237+2.1	37.485	13.23+0.3	74.97	74.97	1237	74.97	13.818	1237	1237	---	1	0.45	0.45	37.485	2.646
Min.	---	---	0+2.1	1.029	0+0.3	3.234	2.058	0	0	0	0	0	---	0.3	0.3	---	1.029	0
Step size	---	---	4.851	0.147	0.147	0.294	0.294	4.851	0.294	0.294	4.851	4.851	---	---	---	---	0.147	0.147

Parameter number	Function	Factory setting
240	Restart in the event of loss of flame during operation 0: None 1: None 2: 1 x restart	0
241.00	Valve proving 0: OFF 1: ON	1
241.01	Valve proving 0: During prepurge time 1: During postpurge time	1
241.02	Valve proving 0: According to parameter 241.01 1: During prepurge time and postpurge time	0
515	Actuator position during prepurge time and postpurge time 0: Purging in low-fire 1: Purging in high-fire	1
247	Continuous pilot (during operation) 0 = OFF 1 = ON	0

## Legend

tw	Waiting time
TSA	Safety time
t1	Prepurge time
t3	Preignition time
t3n	Postignition time parameter 257 +0.3 seconds
t4	Interval: End of safety time – fuel valve V1 ON
t5	Interval: Pilot valve OFF – load controller release
t8	Postpurge time
t9	Interval: Fuel valve V1 ON – pilot valve OFF
t10	Specified time air pressure switch message (timeout)
t11	Opening time of actuator (timeout)
t12	Closing time of actuator (timeout)
t22	2 <sup>nd</sup> safety time
td1	Test time atmospheric pressure
td2	Test time gas pressure
td3	Test space filling
td4	Test space evacuating
1)	Reaction time to a change of signal by the air pressure switch contact (opens) and flame-out response time in the event of loss of flame
2)	Reaction time to a change of signal by the inputs (e.g. pressure switch-min)
3)	Flame detection time
4)	Minimum time $td1 + td2 + td3 + td4$ if: parameter 241.00 = 1 (ON), after power ON, with a non-volatile lockout, parameter 234 (postpurge time) = 0 (postpurging) or parameter 241.01 = 0
5)	Minimum time $td1 + td2 + td3 + td4$ if: Parameter 241.00 = 1 (ON) and parameter 234 (postpurge time) >0 (postpurging) and parameter 241.01 = 1

# 11 Inputs and outputs / internal connection diagram

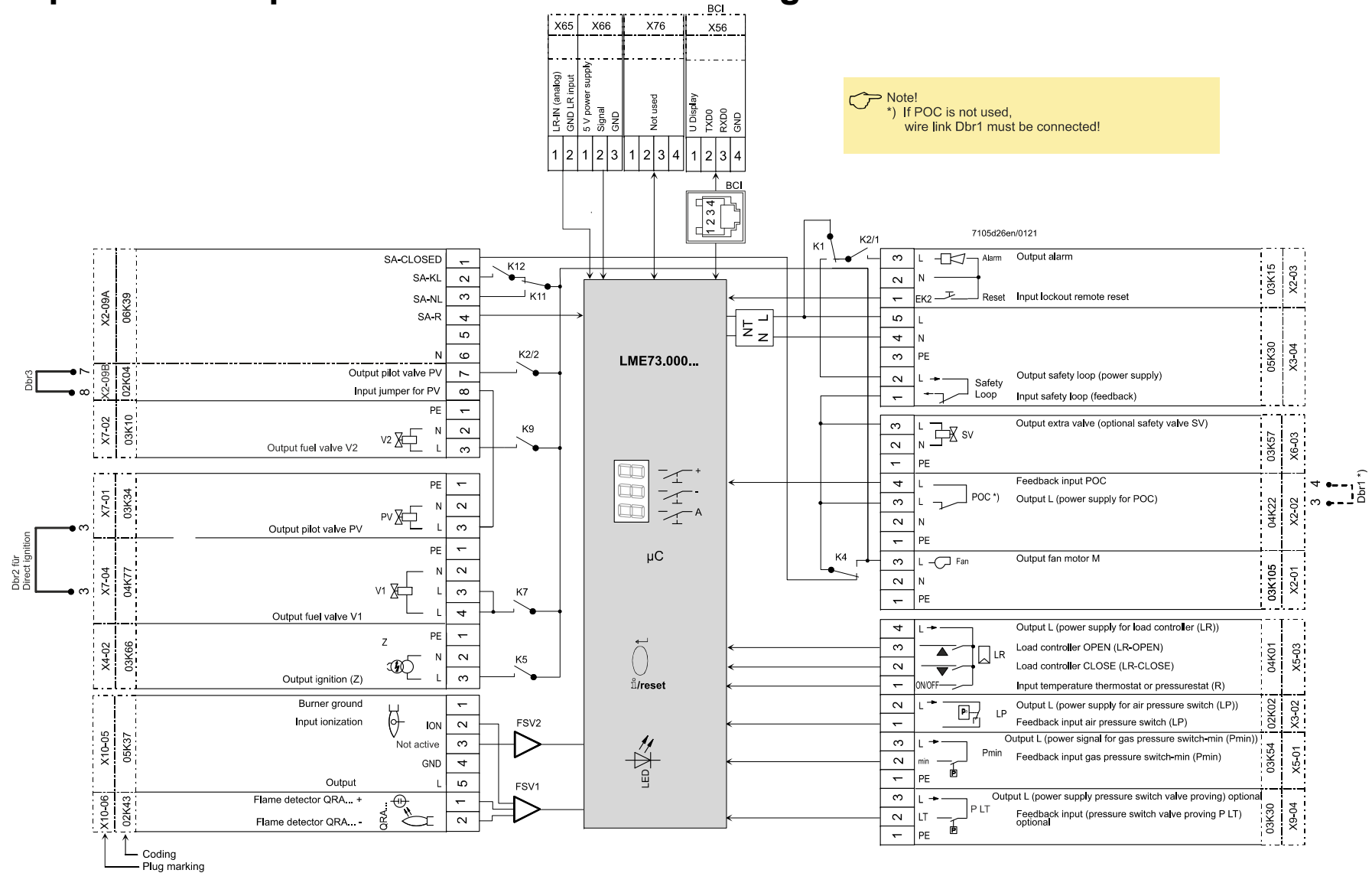

Figure 8: Inputs and outputs / internal connection diagram

## 12 Parameter list (AZL2)

### Abbreviations for password level:

HF	Heating engineer
OEM	Manufacturer of the original product

Parameter number	Parameter	Edit	Value range		Increment	Factory setting	Password level reading from level	Password level writing from level
			Min.	Max.				
<b>000</b>	<b>Internal parameter</b>							
41	Heating engineer (HF) password (4 characters)	Edit	xxxx	xxxx	---	---	---	OEM
42	OEM's password (5 characters)	Edit	xxxxx	xxxxx	---	---	---	OEM
60	Backup/restore	Edit	Restore	Backup	---	---	---	SO
<b>100</b>	<b>General</b>							
102	Identification date	Read only	---	---	---	---	Info	---
103	Identification number	Read only	0	9999	1	0	Info	---
113	Burner identification	Edit	x	xxxxxxxx	1	burnErlId	Info	SO
123	Min. power control step	Edit	1%	10%	0,1	2	SO	SO
140	Mode display for the 7-segment display 1 = standard (program phase) 2 = flame 1 (QRA/ION) 3 = flame 2 (QRB/QRC) ⇒ not used 4 = active power (power value)	Edit	1	4	1	4	SO	SO
164	Number of startups resettable	Resettable	0	999999	1	0	Info	Info
166	Total number of startups	Read only	0	999999	1	0	Info	---
170.00	Switching cycles relay contact K12	Read only	0	99999999	1	0	Info	---
170.01	Switching cycles relay contact K11	Read only	0	99999999	1	0	Info	---
170.02	Switching cycles relay contact K2	Read only	0	99999999	1	0	Info	---
170.03	Switching cycles relay contact K1	Read only	0	99999999	1	0	Info	---
171	Signaling of "Switching cycle exceeded" for one of the relay contact counters (parameters 170.00 to 170.03) → not active	Read only	0	99999999	1	1000000	Info	---



Parameter number	Parameter	Edit	Value range		Increment	Factory setting	Password level reading from level	Password level writing from level
			Min.	Max.				
<b>200</b>	<b>LME7 burner control</b>							
224	Specified time air pressure switch	Edit	0 s	13.818 s	0.294 s	13.818 s	SO	OEM
225	Prepurge time +2.1 seconds	Edit	0 s	1237 s	4.851 s	29.106 s	SO	OEM
226	Preignition time	Edit	1.029 s	37.485 s	0.147 s	6.174 s	SO	OEM
230	Interval (t4): End of safety time - fuel valve V1 ON	Edit	3.234 s	74.97 s	0.294 s	9.408 s	SO	OEM
231	Interval (t9): Fuel valve V1 ON – pilot valve OFF	Edit	0 s	74.97 s	0.294 s	2.646 s	SO	OEM
232	Interval (t5): Pilot valve OFF – release of load controller	Edit	2.058 s	74.97 s	0.294 s	8.820 s	SO	OEM
234	Postpurge time	Edit	0 s	1237 s	4.851 s	19.404 s	SO	OEM
240	Restart in the event of loss of flame during operation 0: None 1: None 2: 1 x restart	Edit	0	2	1	0	SO	OEM
241.00	Valve proving 0 = OFF 1 = ON	Edit	0	1	1	1	SO	OEM
241.01	Valve proving 0 = during prepurge time 1 = during postpurge time	Edit	0	1	1	1	SO	OEM
241.02	Valve proving 0 = according to parameter 241.01 1 = during prepurge time and postpurge time	Edit	0	1	1	0	SO	OEM
242	Valve proving - test space evacuating	Edit	0 s	2.648 s	0.147 s	2.648 s	SO	OEM
243	Valve proving - test time atmospheric pressure	Edit	1.029 s	37.485 s	0.147 s	10.290 s	SO	OEM
244	Valve proving - test space filling	Edit	0 s	2.648 s	0.147 s	2.648 s	SO	OEM
245	Valve proving - test time gas pressure	Edit	1.029 s	37.485 s	0.147 s	10.290 s	SO	OEM
247	Continuous pilot (during operation) 0 = OFF 1 = ON	Edit	0	1	1	0	SO	OEM
257	Postignition time +0.3 seconds	Edit	0 s	13,23 s	0.147 s	2.205 s	SO	OEM
259	Opening time of actuator (timeout)	Edit	0 s	1237 s	4.851 s	300.762 s	SO	OEM
260	Closing time of actuator (timeout)	Edit	0 s	1237 s	4.851 s	300.762 s	SO	OEM
515	Actuator position during prepurge time and postpurge time 0: Purging in low-fire 1: Purging in high-fire	Edit	0	1	1	1	SO	OEM





Parameter number	Parameter	Edit	Value range		Increment	Factory setting	Password level reading from level	Password level writing from level
			Min.	Max.				
<b>600</b>	<b>Power setting</b>							
654	Analog input (feedback potentiometer ASZxx.3x required) 0 = 3-position step input 1 = 0...10 V 2 = 0...135 Ω 3 = 0...20 mA 4 = 4 to 20 mA with a non-volatile lockout at I < 4 mA 5 = 4...20 mA	Edit	0	5	1	1	SO	SO
<b>700</b>	<b>Error history</b>							
701	Current error: 00: Error code 01: Startup meter reading 02: HMI phase 03: Power value	Read only	2 0 --- 0%	255 999999 --- 100%	1 1 --- 1	--- --- ---	Service	---
702	Latest error in the history 00: Error code 01: Startup meter reading 02: HMI phase 03: Power value	Read only	2 0 --- 0%	255 999999 --- 100%	1 1 --- 1	--- --- ---	Service	---
• • •								
711	Oldest error in the history 00: Error code 01: Startup meter reading 02: HMI phase 03: Power value	Read only	2 0 --- 0%	255 999999 --- 100%	1 1 --- 1	--- --- ---	Service	---
<b>900</b>	<b>Process data</b>							
936	Normalized speed	Read only	0%	100%	0.01%	---	Service	---
951	Mains voltage	Read only	0 V	LME73.000A1: 175 V LME73.000A2: 350 V	1 V	---	Service	---
954	Flame intensity	Read only	0%	100%	1%	---	Service	---

# 13 Error code list

Error code		Clear text	Possible causes
AZL2	LED display (alternating)		
Loc: 2	Loc 2	No establishment of flame at the end of safety time	<ul style="list-style-type: none"> <li>Faulty or soiled fuel valves</li> <li>Defective, soiled or incorrectly connected flame detector</li> <li>Poor adjustment of burner, no fuel</li> <li>Faulty ignition equipment</li> </ul>
Loc: 3	Loc 3	Air pressure faulty (air pressure switch welded in no-load position, decrease to specified time (air pressure switch flame-on response time)	Air pressure switch faulty <ul style="list-style-type: none"> <li>Loss of air pressure signal after specified time</li> <li>Air pressure switch has welded in no-load position</li> </ul>
Loc: 4	Loc 4	Extraneous light	Extraneous light during burner startup
Loc: 5	Loc 5	Air pressure faulty, air pressure switch welded in working position	Time supervision air pressure switch <ul style="list-style-type: none"> <li>Air pressure switch has welded in working position</li> </ul>
Loc: 6	Loc 6	Fault of actuator	<ul style="list-style-type: none"> <li>Actuator faulty or blocked</li> <li>Faulty connection</li> <li>Wrong adjustment</li> </ul>
Loc: 7	Loc 7	Loss of flame	Too many losses of flame during operation (restart limitation) <ul style="list-style-type: none"> <li>Faulty or soiled fuel valves</li> <li>Faulty or soiled flame detector</li> <li>Poor adjustment of burner</li> </ul>
Loc: 10	Loc 10	Non-volatile lockout with alarm output switched on at terminal X2-03 pin 3 (fault lamp ON)	Wiring error or internal error, other errors
Loc: 10	Loc 10	Non-volatile lockout with alarm output switched off at terminal X2-03 pin 3 (fault lamp OFF)	Output contact error (welded contact of an output relay)
Loc: 12	Loc 12	Valve proving	Fuel valve V1 leaking
Loc: 13	Loc 13	Valve proving	Fuel valve V2 leaking
Loc: 14	Loc 14	POC error	Error valve closure control POC
Loc: 22	Loc 22	Safety loop open	<ul style="list-style-type: none"> <li>Gas pressure switch-max open</li> <li>Safety temperature limiter has tripped</li> </ul>
Loc: 60	Loc 60	Analog power source 4...20 mA, I <4 mA	Wire breakage
Loc: 138	Loc 138	Restore process successful	Restore process successful
Loc: 139	Loc 139	No PME7 detected	No PME7 plugged in
Loc: 167	Loc 167	Manual locking	Manual locking
Loc: 206	Loc 206	AZL2 incompatible	Use the latest version

Error code		Clear text	Possible causes
AZL2	LED display (alternating)		
rSt Er1	rSt Er1	Error in compatibility between PME7 and LME7 during restore process	Program sequence of PME7 does not match the LME7
rSt Er2	rSt Er2	Error in compatibility between PME7 and LME7 during restore process	LME7 hardware does not match the PME7
rSt Er3	rSt Er3	Error during restore process	<ul style="list-style-type: none"> <li>• PME7 faulty</li> <li>• PME7 removed during restore process</li> </ul>
bAC Er3	bAC Er3	Error in compatibility between PME7 and LME7 during backup process	Program sequence of PME7 does not match the LME7
Err PrC	Err PrC	Error in PME7	<ul style="list-style-type: none"> <li>• Data content of the PME7 defective</li> <li>• No PME7 plugged in</li> </ul>

# 14 Legend

AL	Alarm device
Dbr...	Wire link
	Lockout reset button (info button)
 /reset (EK1)	
EK2	Remote lockout reset button
FSV	Flame signal amplifier
ION	Ionization probe
Kx	Relay contact
LED	3-color signal lamp
LP	Air pressure switch
LR	Load controller
LR-OPEN	Load controller OPEN position
LR-CLOSED	Load controller CLOSED position
M	Fan motor
NT	Power supply unit
P LT	Pressure switch - valve proving
Pmax	Pressure switch-max
Pmin	Pressure switch-min
POC	Valve closure control (proof of closure)
PV	Pilot valve
QRA	Flame detector
R	Control thermostat or pressurestat
SA	Actuator
SA-KL	Actuator low-fire
SA-NL	Actuator high-fire
SA-R	Actuator feedback
SA-CLOSED	Actuator CLOSED
SA-ZL	Actuator ignition load
SK	Safety Loop
SV	Safety valve
V1	Fuel valve
V2	Fuel valve
Z	Ignition transformer
	Input/output signal 1 (ON)
	Input/output signal 2 (OFF)
	Permissible signal 1 (ON) or 0 (OFF)

# 15 List of figures

---

Figure 1: Program sequence for fuel trains <b>G</b> , <b>Gp1/1</b> , and <b>Gp1/2</b> .....	5
Figure 2: Fuel train gas direct ignition (G), 1-stage.....	7
Figure 3: Fuel train gas pilot ignition 1 (Gp1/1), 1-stage.....	7
Figure 4: Fuel train gas pilot ignition 1 (Gp1/2), 1-stage, with valve proving.....	8
Figure 5: Fuel train gas direct ignition 1 (Gp1/2), 1-stage, with valve proving.....	8
Fig. 6: Valve proving with separate pressure switch.....	9
Figure 7: Connection diagram for LME73.000Ax with SQM4.....	12
Figure 8: Inputs and outputs / internal connection diagram.....	15