

SIEMENS

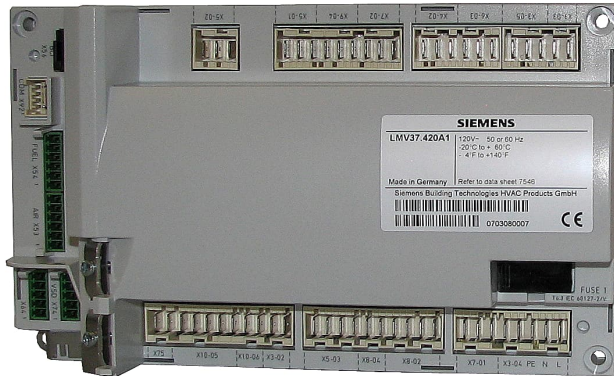

LMV37.400Ax
LMV37.420Ax

Basic unit with integrated fuel-air ratio control for forced draft burners

Basic Documentation

The LMV37.4 and this Basic Documentation are intended for OEMs which integrate the units in their products!

Software version
V03.80

CC1P7546en
21.05.2021

Smart Infrastructure

Supplementary documentation

User Documentation Modbus AZL2..... A7541

Environmental Product Declaration LMV2 / LMV3.....E7541 *)

Installation and Operating Instructions PC Software ACS410J7352

Data 'Sheet LMV37.4..... N7546

Product Range Overview LMV2 / LMV3Q7541

*) On request

Contents

1	Safety notes	10
1.1	Warning notes	10
1.2	Mounting notes	11
1.3	Installation notes.....	12
1.4	Electrical connection of the LMV37.4	13
1.5	Connection BC interface via integrated RJ11 jack (X56)	14
1.6	Electrical connection of flame detectors.....	15
1.7	Commissioning notes	15
1.8	Notes on settings and parameter settings.....	17
1.9	Standards and certificates	18
1.10	Service notes.....	19
1.11	Life cycle.....	19
1.12	Disposal notes.....	19
2	Makeup of structure / function description	20
2.1	For Europe.....	20
2.2	For North America	20
2.3	General information	21
3	Type summary	21
4	Technical Data	22
4.1	Basic unit LMV37.4.....	22
4.1.1	Terminal loading «Inputs»	23
4.1.2	Terminal loading «Outputs»	23
4.1.3	Analog output / load output X74 pin 3	25
4.1.4	Cable lengths.....	25
4.1.5	Cross-sectional areas.....	25
4.1.6	Connections of actuators.....	25
4.2	Signal cable AGV50 from AZL2 → BC interface	26
4.3	Environmental conditions	26
4.4	Flame detector.....	27
4.4.1	Ionization probe	27
4.4.2	UV flame detectors QRA2 / QRA4 / QRA10.....	29
4.4.3	Photoresistive flame detectors QRB1 / QRB3.....	30
4.4.4	Yellow flame detector QRB4	31
4.4.5	Blue-flame detectors QRC.....	32
5	Dimensions	33
5.1	LMV37.4	33
6	Display and diagnostics	34
7	Basic unit LMV37.4	34
7.1	Description of inputs and outputs	34
7.2	Flame detectors.....	35
7.2.1	Loss of flame	35

7.2.2	Extraneous light	36
7.2.3	No flame at the end of safety time	36
7.2.4	Flame intensity	36
7.2.5	Supervision of flame detector	36
7.2.6	Flame detection sensitivity	37
7.3	Digital inputs	38
7.3.1	Safety loop X3-04 pin 1 and 2	39
7.3.2	Burner flange X3-03, pin 1 and 2	40
7.3.3	Input for external load controller (ON / OFF) X5-03, pin 1	40
7.3.4	Inputs X5-03 pin 2 and 3 (Open / Close or stage 2 / stage 3)	40
7.3.5	Air pressure switch X3-02	41
7.3.6	Gas pressure switch valve proving – or heavy oil direct start X9-04	42
7.3.7	Gas / oil pressure switch-min, start release gas X5-01	44
7.3.8	Setting the time for making the pressure switch test	46
7.3.9	Gas / oil pressure switch-max / or POC contact, start release oil / additional speed-dependent air pressure switch X5-02	47
7.3.10	Reset X8-04, pin 1	50
7.4	Digital outputs	51
7.4.1	Output alarm type No-SI – X3-05, pin 2	51
7.4.2	Fan motor contactor type SI – X3-05, pin 1	51
7.4.3	Fan continuous purging X3-05, pin 3	51
7.4.4	Output ignition type SI (IGNITION) X4-02	52
7.4.5	Outputs fuel valves type SI V1 / V2 / V3 / PV) X8-02, X7-01, X7-02	53
7.4.6	Output safety valve type SI X6-03	53
7.4.7	Output for operation display, type SI X8-04 pin 2	53
7.5	Program sequence	54
7.5.1	Time parameters	54
7.5.2	Valve proving	55
7.5.2.1	Valve proving with separate pressure switch X9-04	56
7.5.2.2	Valve proving via gas pressure switch-min X5-01	57
7.5.2.3	Lockout phase (phase 00)	57
7.5.2.4	Safety phase (phase 01)	58
7.5.3	Special functions during the program sequence	59
7.5.3.1	Reset / manual lockout	59
7.5.3.2	Alarm upon start prevention	60
7.5.3.3	Possible start preventions	61
7.5.3.4	Restart counter	61
7.5.3.5	Start without prepurging (as per EN 676)	64
7.5.3.6	Gas shortage program	65
7.5.3.7	Program stop function	66
7.5.3.8	Forced intermittent operation (<24 hours)	66
7.5.3.9	Low-fire shutdown	66
7.5.3.10	Continuous fan	67
7.5.3.11	Test function for approval of burner – loss-of-flame test (TÜV test)	68
7.5.3.12	Postpurging in the lockout position	69
7.5.3.13	Switching back to pilot	70
7.6	Fuel trains (application examples)	72
7.7	Sequence diagrams	81
7.7.1	Gas direct ignition «G», «G mod», «G mod pneu»	82

7.7.2	Gas pilot ignition 1 «Gp1», «Gp1 mod», «Gp1 mod pneu».....	83
7.7.3	Gas pilot ignition 2 «Gp2», «Gp2 mod», «Gp2 mod pneu».....	84
7.7.4	Light oil direct ignition «Lo», «Lo mod», «Lo 2-stage», «Lo 3-stage»	85
7.7.5	Light oil pilot ignition «LoGp» «LoGp mod» «LoGp 2 stage»	86
7.7.6	Heavy oil direct ignition «Ho», «Ho mod separate circulation control», «Ho 2-stage separate circulation control»	87
7.7.7	Heavy oil direct ignition «Ho», «Ho mod without circulation control», «Ho 2-stage without circulation control», «Ho 3-stage without circulation control»	88
7.7.8	Legend to the sequence diagrams	89
8	Selection of operating mode	92
8.1	Deleting curves	94
9	Connection to load controllers	95
9.1	Load controller ON contact X5-03 pin 1	95
9.2	External load controller via contacts X5-03, pin 2 / pin 3.....	95
9.3	Default output via building automation – X92	98
9.4	Manual output.....	100
9.5	Output with curve settings	100
9.6	External load controller via analog input X64 pin 1 / X64 pin 2	101
9.6.1	Switching thresholds for modulating operation.....	101
9.6.2	Switching thresholds for multistage operation	102
9.7	Prioritization of load controller sources.....	103
9.7.1	Emergency operation with several load controller sources	104
9.7.2	Manual control	104
10	Electronic ratio control	105
10.1	General.....	105
10.2	Behavior outside the operating positions.....	105
10.2.1	Traveling speed	105
10.2.2	Home position.....	105
10.2.3	Prepurging	106
10.2.4	Ignition	106
10.2.5	Postpurging	106
10.3	Modulating operation	107
10.3.1	Definition of curves	108
10.3.2	Traveling speed / maximum curve slope	109
10.3.3	Entering the running position.....	110
10.3.4	Operating position	110
10.3.5	Limitation of modulation range	111
10.3.6	Setting the minimum and maximum output	112
10.4	Multistage operation	113
10.4.1	Definition of curves.....	113
10.4.2	Traveling speed	113
10.4.3	Adjustment of output.....	114
10.4.4	Entering the operating position.....	114
10.4.5	Operating position	114
10.4.6	Limitation of modulation range	115
10.5	End of operating position.....	115

10.6	Notes on settings and parameter settings	116
11	Actuators X53 / X54	117
11.1	Function principle.....	117
11.2	Definition of angles	117
11.3	Referencing.....	118
11.3.1	Reference travel.....	120
11.4	Direction of rotation.....	122
11.5	Monitoring the actuator positions	123
11.6	Changing the error detection band for monitoring the actuator positions	125
11.7	Forced travel	125
11.8	Detection of line interruptions	125
11.9	Protection against actuator mixup.....	126
11.9.1	Proposal for implementation	126
12	Fan control	127
12.1	Function principle.....	127
12.2	Activation of VSD/PWM fan	127
12.3	VSD control X74 pin 3.....	128
12.4	PWM fan control X64 pin 3	128
12.5	Safe separation of mains voltage and protective extra low-voltage.....	129
12.6	Ramp time.....	129
12.7	Acquisition of speed.....	130
12.7.1	Acquisition of speed with proximity switch	130
12.7.2	Acquisition of speed with Hall generator.....	131
12.7.3	Forced travel fan	132
12.8	Speed control.....	133
12.9	Speed supervision	134
12.9.1	Extended speed supervision.....	135
12.10	Setting the parameters of VSD	136
12.11	Standardization of speed	137
12.12	Control of fan motor with pneumatic fuel-air ratio control	141
12.13	EMC of LMV37.4 and VSD	141
12.14	Special conditions for PWM fan in electronic fuel-air ratio control system...	141
12.14.1	Characteristics PWM fan	142
12.14.2	Acquisition of speed PWM fan	143
12.15	Trim function	144
12.15.1	Settings and mode of operation.....	145
12.15.2	Optional internal checks.....	146
12.15.3	External tests (optional)	148
12.16	Description of connection terminals	150
12.16.1	VSD.....	150
12.16.2	PWM fan	150
13	Load output X74 pin 3	151
13.1	Safe separation of mains voltage and extra low-voltage	151
13.2	Modulating operation	152

13.3	2-stage operation.....	152
13.4	3-stage operation.....	152
14	Fuel meter input X75 pin 1 / X75 pin 2	153
14.1	Configuration of fuel meter	153
14.1.1	Types of fuel meters	153
14.1.2	Configuration of pulses per volume unit	153
14.1.3	Reading and resetting the meter readings	153
14.2	Fuel throughput	154
14.2.1	Configuration	154
14.2.2	Reading out the fuel throughput	154
15	Connection and internal diagram	155
16	Special feature: Burner identification.....	156
17	Connection to superposed systems.....	156
17.1	General information and building automation functions	156
17.2	Modbus.....	158
18	PC software ACS410	159
19	Error history.....	160
19.1	Error classes.....	160
19.2	Makeup of error history.....	161
20	Lifecycle function	161
21	Safety notes on use of the AZL2.....	162
22	Operating via AZL2.....	163
22.1	Description of unit/display and buttons.....	163
22.2	Meaning of symbols on the display	164
22.3	Brightness of display	164
22.4	Special functions	165
22.4.1	Manual lockout	165
22.4.2	Manual control (manual request for output).....	166
22.5	Timeout for menu operation	166
22.6	Backup / restore	167
22.6.1	Backup.....	168
22.6.2	Restore	170
23	Operation of LMV37.4 via the AZL2	172
23.1	Normal display.....	172
23.1.1	Display in standby mode	172
23.1.2	Display during startup / shutdown	172
23.1.2.1.	Display of program phases.....	172
23.1.2.2.	Display of program phase with remaining running time until end of the phase is reached	172
23.1.2.3.	List of phase displays	173
23.1.3	Display of operating position	174
23.1.4	Fault status messages, display of errors and info	175

23.1.4.1.	Display of errors (faults) with lockout.....	175
23.1.4.2.	Reset.....	175
23.1.4.3.	Activating info / service mode from lockout.....	175
23.1.4.4.	Error with safety shutdown.....	176
23.1.4.5.	General information	176
23.1.4.6.	Prevention of startup.....	176
23.1.4.7.	Safety loop	176
24	Menu-driven operation	177
24.1	Assignment of levels	177
25	Info level	178
25.1	Display of info level.....	178
25.2	Display of info values (examples)	179
25.2.1	Identification date	179
25.2.2	Identification number.....	179
25.2.3	Burner identification	180
25.2.4	Number of startups resettable.....	181
25.2.5	Total number of startups	182
25.2.6	End of info level	182
26	Service level	183
26.1	Display of service level	183
26.2	Display of service values (example)	184
26.2.1	Number of faults.....	184
26.2.2	Error history	184
26.2.3	Intensity of flame.....	184
26.2.4	End of service level.....	185
27	Parameter level	186
27.1	Entry of password	187
27.2	Entry of burner identification	189
27.3	Change of heating engineer's password.....	191
27.4	Change of OEM's password	192
27.5	Use of parameter level.....	193
27.6	Structure of parameter levels.....	194
27.7	Parameters without index, with direct display	195
27.7.1	Using the example of parameter 208: Program stop	195
27.8	Parameters without index, with no direct display (with parameters having a value range >5 digits)	197
27.8.1	Using the example of parameter 162: Operating hours resettable	197
27.9	Parameter with index, with direct display.....	199
27.9.1	Using the example of parameter 501: No-flame positions fuel actuator	199
27.10	Parameters with index, with no direct display	201
27.10.1	Using the example of parameter 701: Errors.....	201
27.11	Fuel-air ratio curves – settings and commissioning.....	204
27.11.1	Initial commissioning.....	204
27.11.2	Setting curvepoints P0 and P9 for modulating operation («G mod», «Gp1 mod», «Gp2 mod» and «Lo mod»).....	207

27.11.3	Setting curvepoints P0 and P9 for «G mod pneu», «Gp1 mod pneu» and «Gp2 mod pneu»	208
27.11.4	Warm settings for modulating operation («G mod», «Gp1 mod», «Gp2 mod» and «Lo mod»)	209
27.11.5	Warm settings for modulating mode («G mod pneu», «Gp1 mod pneu» and «Gp2 mod pneu»).....	214
27.11.6	Cold settings for «G mod», «Gp1 mod», «Gp2 mod» and «Lo mod»	214
27.11.7	Cold settings for «G mod pneu», «Gp1 mod pneu» and «Gp2 mod pneu»	215
27.11.8	Editing the curvepoints	216
27.11.9	Interpolating the curvepoints	217
27.11.10	Setting of curvepoints for multistage mode («Lo 2-stage» and «Lo 3-stage»).....	220
27.11.11	Warm settings for «Lo 2-stage» and «Lo 3-stage»	221
27.11.12	Cold settings for multistage mode («Lo 2-stage» and «Lo 3-stage»).....	225
27.11.13	Intensity of flame during curve settings	226
28	Parameter list LMV37.4	227
29	Error code list (all LMV2 types / LMV3 types).....	243
30	Revision history of LMV37.4.....	260
31	List of figures	265

1 Safety notes

1.1 Warning notes



To avoid injury to persons, damage to property or the environment, the following warning notes must be observed!

LMV37.4 are safety devices! Do not open, interfere with or modify the units. Siemens does not assume responsibility for damage resulting from unauthorized interference!

Additional safety notes contained in other chapters of this document must be observed as well!

After commissioning and after each service visit, check the flue gas values across the entire output range!

The present Basic Documentation describes a wide choice of applications and functions and shall serve as a guideline. The correct functioning of the units is to be checked and proven by function checks on a test rig or on the plant itself!

- All activities (mounting, installation and service work, etc.) must be performed by qualified personnel
- Degree of protection IP40 as per EN 60529:1991 + A1:2000 + A2:2013 for the LMV37.4 must be ensured through adequate mounting of the LMV37.4 by the burner or boiler manufacturer
- Before making any wiring changes in the connection area, completely isolate the plant from mains supply (all-polar disconnection). Ensure that the plant cannot be inadvertently switched on again and that it is indeed dead. If not disconnected, there is a risk of electric shock hazard
- Protection against electric shock hazard on the LMV37.4 and on all connected electrical components must be ensured through adequate mounting. In terms of design, stability, and protection, covers must conform to the EN 60730 series of standards
- After each activity (mounting, installation and service work, etc.), check to ensure that wiring is in an orderly state and that the parameters are correctly set
- Fall or shock can adversely affect the safety functions. Such units must not be put into operation even if they do not exhibit any damage
- When programming the fuel-air ratio control curves, the commissioning engineer must constantly watch the quality of the combustion process (e.g. by means of a flue gas analyzer) and, in the event of poor combustion values or dangerous conditions, take appropriate actions, e.g. by shutting down the LMV37.4 manually
- The following plug-on terminations carry FELV (Functional Extra Low-Voltage) (also refer to chapter *Electrical connection of the LMV37.4*) which means that they do not provide safe separation from mains voltage:
 - The BCI (X56) for the connecting cable of the AZL2 or PC software ACS410
 - COM (X92) for accessories, such as the OCI410These plug-on terminations may be removed or replaced only when the plant is dead (all-polar disconnection)
- The connectors of the connecting cables for the LMV37.4 or other accessories, such as the OCI410 (plugged into the BCI), may only be removed or exchanged when the plant is shut down (all-polar disconnection), since the BCI interface does not provide safe separation from mains voltage
- The connections for the SQM3 or SQN1 actuators do not provide safe separation from mains voltage. Prior to connecting or changing one of these actuators, the plant must be shut down (all-polar disconnection)

To ensure safety and reliability of the LMV37.4, the following points must also be observed:

- Condensation and ingress of humidity must be avoided. Should such conditions occur, make sure that the unit is completely dry before switching on again!
- Static charges must be avoided since they can damage the unit's electronic components when touched.
Recommendation: Use ESD equipment
- If the unit fuse was blown due to overload or a short-circuit at the connection terminals, the LMV37.4 must be replaced since the switching contacts might have been damaged
- If error codes 95...98 appear during operation, this may be an indication of contact problems and the LMV37.4 should be replaced

1.2 Mounting notes

- Ensure that the relevant national safety regulations and standard notes are complied with
- In geographical areas where DIN regulations are in use, the requirements of VDE must be satisfied, especially DIN / VDE 0100, 0550 and DIN / VDE 0722
- The LMV37.4 must be secured with fixing screws M4 (UNC32) or M5 (UNC24), observing a maximum tightening torque of 1.8 Nm and using all 4 fixing points. The additional mounting surfaces on the housing are provided to improve mechanical stability. These must fully rest on the mounting surface to which the unit is secured. The flatness of that mounting surface must be within a tolerance band of 0.3 mm

Note on mounting

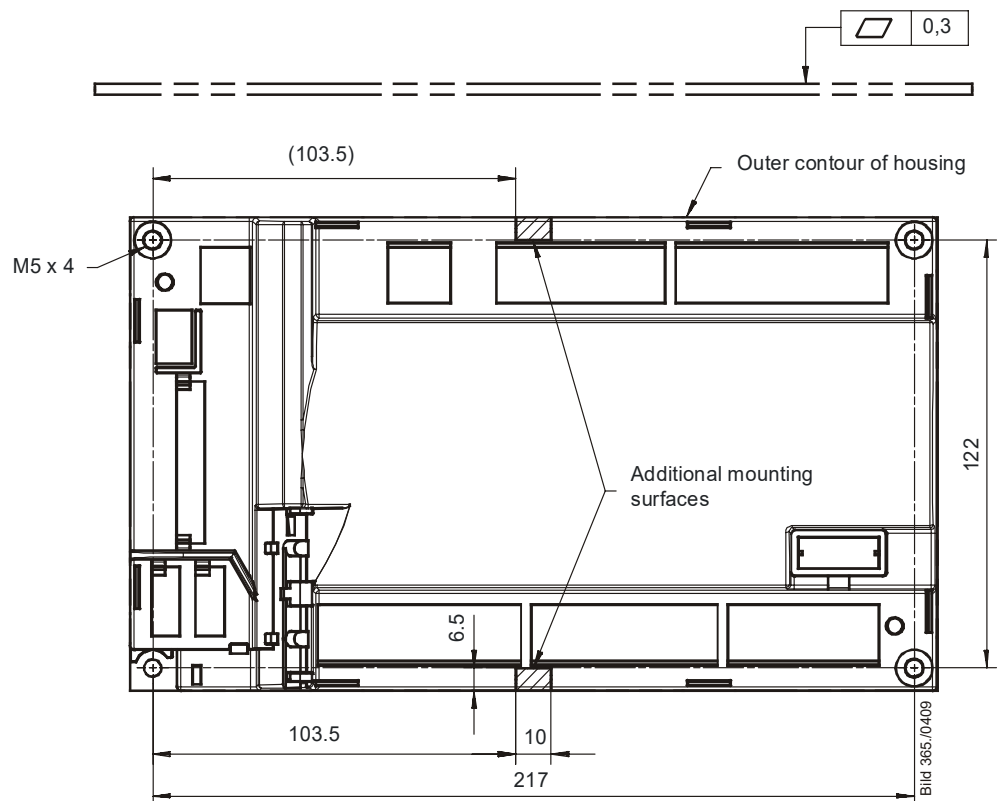

Figure 1: Note on mounting

1.3 Installation notes

- Always run the high-voltage ignition cables separate from the unit and other cables while observing the greatest possible distances
- Ensure that the electrical wiring inside the boiler is in compliance with national and local safety regulations
- Mains power must always be supplied via *L* and *N*. This means that no potential differential must exist between the neutral conductor *N* and protective conductor *PE*
- Phase and neutral conductor must not be interchanged (dangerous malfunctions, loss of protection against electric shock hazard, etc.)
- Make certain that strain relief of the connected cables is in compliance with the relevant standards (e.g., in accordance with the EN 60730 and EN 60335 series of standards)
- Ensure that spliced wires cannot get into contact with neighboring terminals. Use adequate ferrules
- The burner manufacturer must protect unused terminals of the LMV37.4 by fitting dummy plugs (exception: X64 (reserve) and X74)
- When making the wiring, the AC 120 V or AC 230 V section must be strictly separated from other voltage sections, thus ensuring protection against electric shock hazard. For more detailed information, refer to chapter *Electrical connection of the LMV37.4*
- The connectors of the connecting cables for the LMV37.4 may only be removed or exchanged when the plant is turned off (all-polar disconnection), since the BCI interface does not provide safe separation from mains voltage
- AGV50 signal cable between LMV37.4 and AZL2
Since the BCI carries FELV (refer to chapter *Electrical connection of the LMV37.4*), the connection between LMV37.4 and AZL2 must be established via the AGV50 signal cable, or by ensuring compliance with the specification. The signal cable is specified for use under the burner hood. When using other types of signal cable that do not meet the specification requirements, safety against electric shock hazard is not necessarily ensured
- Do not lay signal cable AGV50 from the LMV37.4 to the AZL2 together with other cables
- Service operation with a longer signal cable from the LMV37.4:
If a longer signal cable is required for service work for example (short-time usage, <24 hours), note that the above application under the burner hood no longer applies and, for this reason, the signal cable can be subjected to increased mechanical stress. In that case, use a reinforced signal cable
- Both the AGV50 signal cable and the AZL2 must be shipped and stored so that no damage due to dust and water can occur when the products are used in the plant
- To ensure protection against electric shock hazard, make certain that, prior to switching on power, the AGV50 signal cable is correctly connected to the AZL2
- The AZL2 must be used in a dry and clean environment
- The mechanical coupling between the actuators and the controlling elements for fuel and air, or any other controlling elements, must be rigid
- Once the LMV37.4 has been installed in the equipment, a check must be carried out to ensure compliance with the EMC emission requirements!
- When grounded PELV signals are connected to the SELV terminals of the burner control, they also become PELV voltages (according to EN 60730-1:2016, chapter 11.2.7, DIN EN 298 chapter 9.2.d)
- An isolating transformer grounded on one side must be used if the wiring takes place with a mains circuit without a grounded conductor or the mains supply between the phases (in accordance with DIN EN 298-1, chapter 9.2.d)
- To prevent high-energy couplings due to magnetic induction or capacitive coupling, the cable lengths must be >10 m on the detector cables and communication lines with a shielded cable, grounded on both sides (based on requirements from EN 13611)
- Testing torque of the screws RAST5 connector: 0.5 Nm
- Testing torque of the screws RAST3.5 connector: 0.25 Nm

1.4 Electrical connection of the LMV37.4

The LMV37.4 operates with the following low-voltages:

- SELV (Safety Extra Low-Voltage) and PELV (Protective Extra Low-Voltage) ensure protection against electric shock hazard
- FELV (Functional Extra Low-Voltage) without safe separation offers no protection which, in the event of fault, would not exclude risks

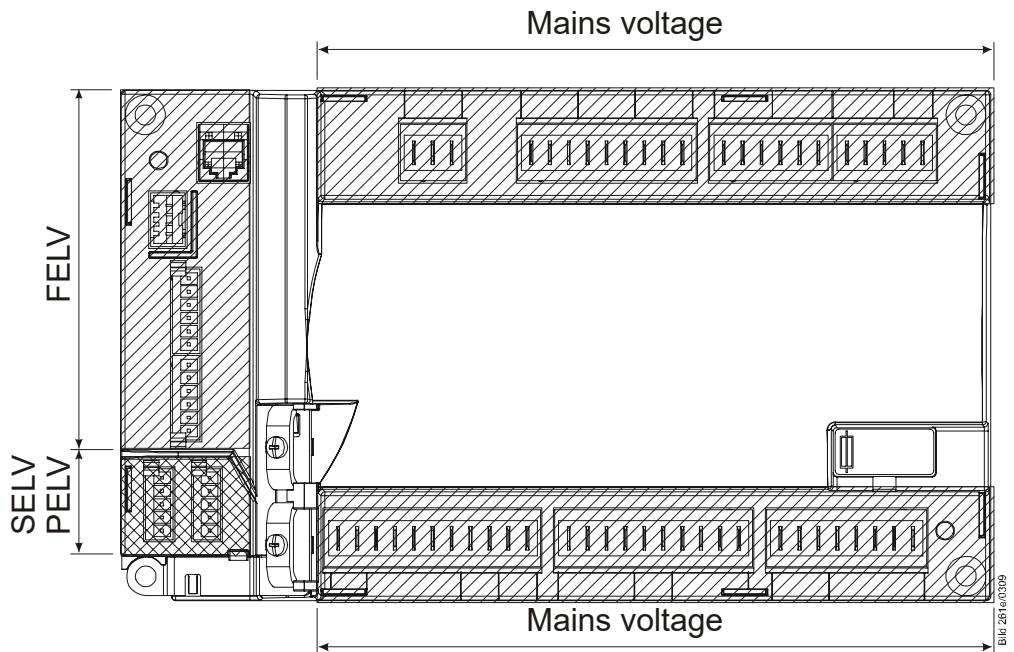

Figure 2: Electrical connection



Note

SELV or PELV depends on the safety class of the connected components. In the case of PELV, the relevant component is connected to protective earth.

1.5 Connection BC interface via integrated RJ11 jack (X56)

- If the BC interface (jack RJ11) is not used, protection against electric shock hazard must be provided (jack must be covered up)
- The AZL2 signal cable or other accessories like the OCI410 interface (plugged into the RJ11 jack), may only be plugged in or disconnected when the unit is dead (all-polar disconnection), since the BC interface does not provide safe separation from mains voltage
- The AZL2 is designed for direct connection to the integrated RJ11 jack on the LMV37.4
- Signal cable from LMV37.4 to AZL2 must conform to certain specifications. Siemens has specified the signal cable for use under the burner hood. When using other signal cables, it is not guaranteed that the required cable features will be met.
- Do not lay the signal cable from the LMV37.4 to the AZL2 together with other cables. Use a separate cable
- Service operation with a longer signal cable from LMV37.4 to AZL2
If a longer signal cable is required for service work, for example (short-time, <24 hours), note that the above usage under the burner hood no longer applies and, for this reason, the signal cable can be subjected to increased mechanical stress. Extra cable sheathing is therefore required
- Both the signal cable and the AZL2 must be shipped and stored so that no damage due to dust and water can occur when used in the plant later on
- To ensure protection against electric shock hazard, make certain that, prior to switching on power, the signal cable is correctly connected to the AZL2
- The AZL2 must be used in a dry and clean environment

Connection interface OCI410 on the BC interface

Connect the OCI410 interface without other extension with the USB interface at your PC, follow the example design below.

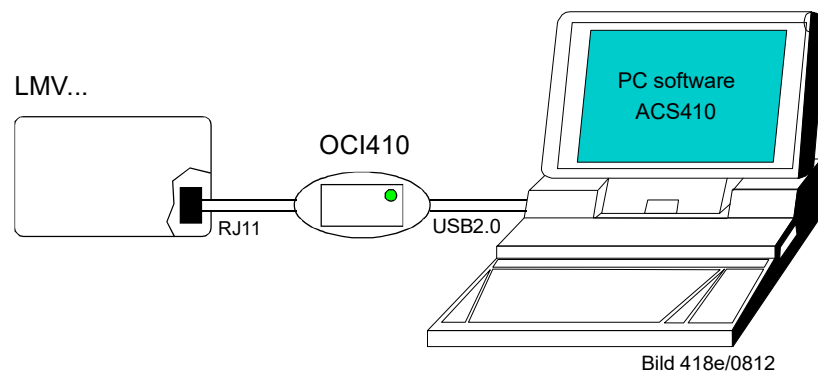

Figure 3: Connection interface OCI410 on the BC interface

1.6 Electrical connection of flame detectors

It is important to achieve practically disturbance-free and loss-free signal transmission:

- Never run the detector cables together with other cables
 - Line capacitance reduces the magnitude of the flame signal
 - Use a separate cable
- Observe the permissible detector cable lengths
- The mains-powered ionization probe is not protected against electric shock hazard. It must be protected against accidental contact
- Earth the burner in compliance with the relevant regulations; earthing the boiler alone does not suffice
- Locate the ignition electrode and the ionization probe such that the ignition spark cannot arc over to the ionization probe (risk of electrical overloads)
- Insulation resistance
 - The insulation resistance must be >50 MΩ between ionization probe and ground
 - Soiled detector holders reduce the insulation resistance, thus supporting creepage currents

1.7 Commissioning notes

- When commissioning the unit, check **all safety functions**
- There is no absolute protection against incorrect use of the RASTx connectors. For this reason, prior to commissioning the plant, check the correct assignment of all connectors
- Electromagnetic emissions must be checked on an application-specific basis

After the plant has been installed and commissioned, the person responsible for the plant / heating engineer must **document** the parameterized values and settings (e.g. curve characteristics) used for fuel-air ratio control.

These data can be printed out with the help of the ACS410 PC software, for example, or must be written down.

This document must be kept in a safe place and checked by the expert.



Caution!

On the OEM level of the LMV37.4, parameter settings other than those specified in the application standards can be made. For this reason, check whether the parameter settings made are in compliance with the relevant application standards (e.g. EN 676, EN 267, etc.), or whether the respective plant demands special approval!

Air-fuel ratio control system

The selected setting values of fuel and combustion air must be assigned such that – while giving consideration to the combustion chamber / fuel pressure, temperature and combustion air pressure, as well as wear of actuators and controlling elements, etc. – correct operation with sufficient amounts of excess air is ensured across the burner's full output range for an extensive period of time (until the next regular inspection is due; also refer to chapter *Monitoring the positions*). This must be proven by the burner / boiler manufacturer by measuring the characteristic combustion process values. If the standardization process is repeated, the fuel-air ratio control system must be rechecked.

LMV37.4

Prior to commissioning the system, the following points must be checked:

- Parameterization of operating mode (e.g. «G mod», «Gp1 mod», «Lo mod», etc.) must accord with the type of burner used (refer to chapter *Selection of operating mode*)
- Correct assignment of the valves to the valve outputs of the LMV37.4
- Correct setting of the time parameters, especially the safety and prepurge times
- Correct functioning of the flame detector in the event of loss of flame during operation (including the response time), with extraneous light, during the prepurge time and, when there is no establishment of flame, at the end of the safety time
- Activation of the valve proving function and determination of the correct leakage rate, if required by the application (refer to chapter *Valve proving*)

The functions of the following available or required input status signals must be checked:

- Air pressure
- Minimum gas pressure / maximum gas pressure or POC
- Gas pressure valve proving
- Minimum oil pressure and maximum oil pressure
- Safety loop (e.g. safety limiter)

Duties of the expert when making the approval tests

	Action	Check / response
a)	Burner startup with flame detector darkened	Lockout at the end of first safety time
b)	Burner startup with flame detector exposed to extraneous light, e.g. to incandescent light with detectors for visible radiation, quartz-halogen bulb or cigarette lighter flame with detectors for UV radiation	Lockout at prepurge time
c)	Simulation of loss of flame during operation. For that, darken the flame detector in the operating position and maintain that state	Lockout or restart, depending on the LMV37.4 configuration
d)	Check the plant's response time with loss of flame during operation. For that purpose, manually disconnect the fuel valves from power and check the time from this moment the LMV37.4 requires to turn off power to the valve	Turning off power to the valves by the LMV37.4 within the period of time permitted for the respective type of plant
e)	Check the safe operation of the burner while giving consideration to LMV37.4 tolerances	<p>LMV37.4 tolerances are the result of a number of factors, such as:</p> <ul style="list-style-type: none"> • Tolerances of actuators plus mechanical linkage to the controlling elements • Environmental conditions (temperature, air conditions) • Type of fuel (calorific value / pressure) • Type of supply air path and flue ways <p>Example of procedure for checking the burner's response to actuator tolerances:</p> <ul style="list-style-type: none"> • Approach a output point in programming mode (e.g. low-fire or high-fire) • Change the actuator's position against the optimum fuel-air ratio setting as can be expected in the case of tolerances • Check the flue gas values with a flue gas analyzer <p>Recommendation: Make this readjustment against the optimum fuel-air ratio setting for one actuator at a time!</p>

Further checks may be required, depending on the field of use and the relevant standards.

1.8 Notes on settings and parameter settings

- When adjusting the electronic fuel-air ratio control system integrated in the LMV37.4, allow for sufficient amounts of excess air since – over a period of time – the flue gas settings are affected by a number of factors (e.g. density of air, wear of actuators and controlling elements, etc.). For this reason, the flue gas values initially set must be checked at regular intervals
- To safeguard against inadvertent or unauthorized parameter transfer from the PC software ACS410 to the LMV37.4, the OEM must assign an **individual burner identification** for each burner. Compliance with this regulation is mandatory to ensure that the LMV37.4 prevents the transfer of parameter sets of some other plant (with inadequate and possibly dangerous parameter values) to the LMV37.4 via the PC software ACS410. In addition, the fuel-air ratio control parameters must be manually approached and the combustion values checked
- With the LMV37.4, it is to be noted that the unit's characteristics are determined primarily by the specific parameter settings rather than the type of LMV37.4. This means that, among other things, each time a plant is commissioned, the parameter settings must be checked and the LMV37.4 must not be transferred from one plant to another without adapting the parameter settings to the new plant
- When using the ACS410 PC software, the safety notes given in the relevant Installation and Operating Instructions (J7352) must also be observed
- A password protects the parameter level against unauthorized access. The OEM allocates individual passwords to the setting levels he can access. The default passwords used by Siemens must be changed by the OEM. These passwords are confidential and may only be given to persons authorized to access such setting levels
- The responsibility for setting the parameters lies with the person who – in accordance with his access rights – made changes to the respective setting level

In particular, the OEM (burner and / or boiler manufacturer) assumes responsibility for the correct parameter settings in compliance with the standards covering the specific applications (e.g. EN 267, EN 676, EN 746-2, etc.).

1.9 Standards and certificates



Applied directives:

- Low-voltage directive 2014/35/EC
- Directive for pressure devices 2014/68/EC
- Gas Appliances Regulation (EU) EU/2016/426
- Electromagnetic compatibility EMC (immunity) *) 2014/30/EC

*) The compliance with EMC emission requirements must be checked after the burner management system is installed in equipment

Compliance with the regulations of the applied directives is verified by the adherence to the following standards / regulations:

- Automatic burner control systems for burners and appliances burning gaseous or liquid fuels DIN EN 298
- Safety and control devices for gas burners and gas burning appliances - Valve proving systems for automatic shut-off valves DIN EN 1643
- Gas/air ratio controls for gas burners and gas burning appliances - Part 2: Electronic types DIN EN 12067-2
- Safety and control devices for burners and appliances burning gaseous and/or liquid fuels — General requirements DIN EN 13611
- Safety and control devices for gas burners and gas-burning appliances - Particular requirements Part 1: Automatic and semi-automatic valves ISO 23552-1
- Automatic electrical controls for household and similar use Part 2-5: Particular requirements for automatic electrical burner control systems DIN EN 60730-2-5

The relevant valid edition of the standards can be found in the declaration of conformity!



Note on EN 60335-2-102

Household and similar electrical appliances - Safety - Part 2-102:

Particular requirements for gas, oil and solid-fuel burning appliances having electrical connections. The electrical connections of the LMV37.4 comply with the requirements of EN 60335-2-102.



EAC Conformity mark (Eurasian Conformity mark)



ISO 9001:2015
ISO 14001:2015
OHSAS 18001:2007



China RoHS
Hazardous substances table:
<http://www.siemens.com/download?A6V10883536>

Type	CE	SP US	FM APPROVED	DIN Geprüft	DVGW	TÜV	AGA
LMV37.400A2	---	---	---	●	●	●	●
LMV37.420A1	●	●	●	●	●	●	●

1.10 Service notes

- **If fuses are blown, the unit must be returned to Siemens** (refer to chapter *Warning notes*)
- Error diagnostics can only be made via the LMV37.4 (BC interface)



Note!

Only authorized persons may replace the fuse (according to DIN EN 298-1, chapter 9.2.r)

1.11 Life cycle

The burner management system has a designed lifetime* of 250,000 burner startup cycles which, under normal operating conditions in heating mode, correspond to approx. 10 years of usage (starting from the production date given on the type field). This lifetime is based on the endurance tests specified in standard DIN EN 298. A summary of the conditions has been published by the European Control Manufacturers Association (Afecon) (www.afecor.org).

The designed lifetime is based on use of the LMV37.4 according to the manufacturer's Data sheet and Basic documentation. After reaching the designed lifetime in terms of the number of burner startup cycles, or the respective time of usage, the LMV37.4 is to be replaced by authorized personnel.

* The designed lifetime is not the warranty time specified in the Terms of Delivery

1.12 Disposal notes

The unit contains electrical and electronic components and must not be disposed of together with household waste. Local and currently valid legislation must be observed.

2 Makeup of structure / function description

The LMV37.4 is a microprocessor-based burner management system with matching system components for the control and supervision of forced draft burners of medium to high capacity.

Integrated in the LMV37.4 are:

- Burner management system complete with valve proving system
- Electronic fuel-air ratio control system for a maximum of 2 SQM3 or SQN1 actuators
- Control of VSD air fan
- Modbus interface

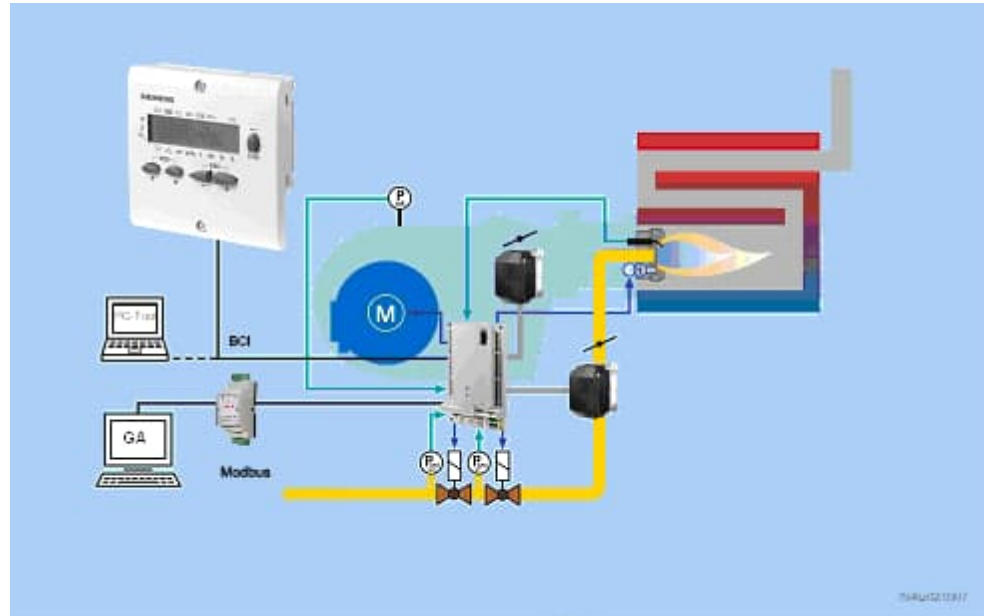

Figure 4: System structure

Example: Modulating gas burner

The system components (AZL2, actuators) are connected directly to the LMV37.4. All safety-related digital inputs and outputs of the LMV37.4 are monitored by a contact feedback network.

The diagram shows the maximum functionality of the LMV37.4. The actual functions are to be determined based on the respective execution / configuration.

2.1 For Europe

For intermittent operation in connection with the LMV37.4, the ionization probe or the QRA, QRB or QRC optical flame detectors can be used. **Continuous operation is possible only when using an ionization probe.**

2.2 For North America

For intermittent operation could in connection with the LMV37.4, the ionization probe or the optical flame detector QRA or QRB can be used. **Continuous operation is possible only when using an ionization probe.**

2.3 General information

The burner management system is operated and parameterized either via the AZL2 display and operating unit or with the help of the PC software ACS410.

The AZL2 with LCD and menu-driven operation facilitates straightforward use and targeted diagnostics. When making diagnostics, the display shows the operating states, the type of error and the point in time the error occurred. Passwords protect the different parameter levels of the burner / boiler manufacturer and heating engineer against unauthorized access.

There is also a COM port which can be accessed from a superposed system, such as a building automation system.

On the BCI interface via interface OCI410, a PC can be connected with the PC software ACS410 (for dual fuel operation on request).

Among other features, the PC software ACS410 enables convenient readout of settings and operating states, parameterization of the LMV37.4 and trend recordings.

The burner / boiler manufacturer can select from different types of fuel trains and make use of a wide choice of individual parameter settings (program times, configuration of inputs / outputs, etc.), enabling him to make optimum adaptations to the relevant application. The actuators are driven by stepper motors and can be positioned with high resolution. Specific features and actuator settings are defined by the LMV37.4.

3 Type summary

Microprocessor-controlled LMV37.4 for single-fuel burners of any capacity for intermittent operation, with electronic fuel-air ratio control, with up to 2 actuators, integrated gas valve proving and VSD control.

Article no.	Type	Mains voltage	Parameter set	Flame detectors	TSA	
					Gas	Oil
BPZ:LMV37.400A2	LMV37.400A2	AC 230 V	Europe	QRA2 / QRA4 / QRA10 / QRB / QRC / ION	3 s	5 s
BPZ:LMV37.420A1	LMV37.420A1	AC 120 V	North America	QRA4 / QRB / ION	5 s	5 s

4 Technical Data

4.1 Basic unit LMV37.4

Mains voltage	
• LMV37.420A1	AC 120 V -15% / +10%
• LMV37.400A2	AC 230 V -15% / +10%
Mains frequency	50 / 60 Hz \pm 6%
Power consumption	<30 W (typically)
Safety class	I, with parts according to II and III to EN 60730-1:2016
Degree of protection	IP00 to EN 60529:1991 + A1:2000 + A2:2013
	<p>Note</p> <p>The burner or boiler manufacturer must ensure degree of protection IP40 for the LMV37.4 as per EN 60529:1991 + A1:2000 + A2:2013 through adequate installation</p>
Mode of operation	Type 2B in accordance with EN 60730-1:2016
Rated surge voltage	In accordance with EN 60730-1:2016 chapter 20 (OC III)
Voltage and current for the purposes of the EMC emitted interference tests	The emitted interference measurement test takes place with mains voltage and maximum power consumption

4.1.1 Terminal loading «Inputs»

- | | |
|--|------------|
| • Permissible primary fuse (Si) (external) | Max. 16 AT |
|--|------------|



Caution!

Risk of damage to the switching contacts!

If the external primary fuse (Si) is blown due to overload or short-circuit at the terminals, the LMV37.4 must be replaced.

- | | |
|--|---------------------------|
| • Unit fuse (F1) (internally) | 6.3 AT (IEC 60127-2:2014) |
| • Mains supply: Input current depending on the operating state of the unit | |

Undervoltage

- | | |
|--|------------------|
| • Safety shutdown from operating position at mains voltage | |
| - LMV37.420A1 | Approx. AC 93 V |
| - LMV37.400A2 | Approx. AC 186 V |
| • Restart on rise in mains voltage | |
| - LMV37.420A1 | Approx. AC 96 V |
| - LMV37.400A2 | Approx. AC 195 V |

Status inputs: Status inputs (with the exception of the safety loop) of the contact feedback network are used for system supervision and require mains-related input voltage

- | | |
|---|---|
| • Input safety loop | Refer to <i>Terminal loading outputs</i> |
| • Input currents and input voltages | |
| - UeMax | UN +10% |
| - UeMin | UN -15% |
| - IeMax | 1.5 mA peak |
| - IeMin | 0.7 mA peak |
| • Contact material recommendation for external signal sources (air pressure switch, pressure switch-min, pressure switch-max, etc.) | Gold-plated silver contacts |
| • Transition / settling behavior / bounce | |
| - Perm. bounce time of contacts when switching on / off | Max. 50 ms
(after the bounce time, contact must stay closed or open) |
| • UN | |
| - LMV37.420A1 | AC 120 V |
| - LMV37.400A2 | AC 230 V |
| • Voltage detection | |
| - On | |
| - LMV37.420A1 | AC 90...132 V |
| - LMV37.400A2 | AC 180...253 V |
| - Off | |
| - LMV37.420A1 | <AC 40 V |
| - LMV37.400A2 | <AC 80 V |

4.1.2 Terminal loading «Outputs»

Total contact loading:

- | | |
|--|----------------------|
| • Rated voltage | |
| - LMV37.420A1 | AC 120 V, 50 / 60 Hz |
| - LMV37.400A2 | AC 230 V, 50 / 60 Hz |
| • Unit input current (safety loop) from: | Max. 5 A |
| - Fan motor contactor | |
| - Ignition transformer | |
| - Valves | |
| - Oil pump / magnetic clutch | |

Individual contact loading:

Fan motor contactor

• Rated voltage	
- LMV37.420A1	AC 120 V, 50 / 60 Hz
- LMV37.400A2	AC 230 V, 50 / 60 Hz
• Rated current	
- LMV37.420A1	2 A
- LMV37.400A2	1,6 A pilot duty load declaration to UL372
• Power factor	$\text{Cos}\varphi > 0.4$

Alarm output

• Rated voltage	
- LMV37.420A1	AC 120 V, 50 / 60 Hz
- LMV37.400A2	AC 230 V, 50 / 60 Hz
• Rated current	1 A
• Load factor	$\text{Cos}\varphi > 0.4$

Ignition transformer

• Rated voltage	
- LMV37.420A1	AC 120 V, 50 / 60 Hz
- LMV37.400A2	AC 230 V, 50 / 60 Hz
• Rated current	
- LMV37.420A1	2 A
- LMV37.400A2	1.6 A pilot duty load declaration to UL372 or 250 VA ignition load declaration to UL372
• Power factor	$\text{Cos}\varphi > 0.2$

Fuel valves

• Rated voltage	
- LMV37.420A1	AC 120 V, 50 / 60 Hz
- LMV37.400A2	AC 230 V, 50 / 60 Hz
• Rated current	
- LMV37.420A1	2 A
- LMV37.400A2	1.6 A pilot duty load declaration to UL372
• Power factor	$\text{Cos}\varphi > 0.4$

Operation display

• Rated voltage	
- LMV37.420A1	AC 120 V, 50 / 60 Hz
- LMV37.400A2	AC 230 V, 50 / 60 Hz
• Rated current	0.5 A
• Power factor	$\text{Cos}\varphi > 0.4$

Safety valve (magnetic clutch / oil pump)

• Rated voltage	
- LMV37.420A1	AC 120 V, 50 / 60 Hz
- LMV37.400A2	AC 230 V, 50 / 60 Hz
• Rated current	
- LMV37.400A2	2 A
- LMV37.420A1	1,6 A pilot duty load declaration to UL372
• Power factor	$\text{Cos}\varphi > 0.4$

Connections for pressure switch

• Rated voltage	
- LMV37.420A1	AC 120 V, 50 / 60 Hz
- LMV37.400A2	AC 230 V, 50 / 60 Hz
• Rated current	1.5 mA
• Power factor	---

Power supply for pressure switch-max / POC (X5-02 pin 3)

• I _{aMax}	<10 mA
---------------------	--------

4.1.3 Analog output / load output X74 pin 3

Accuracy of output voltage	±1%
----------------------------	-----

4.1.4 Cable lengths

• Mains line AC 120 V / AC 230 V	Max. 100 m (100 pF/m)
• Display, BC interface	For installation under the burner hood or in the control panel Max. 3 m (100 pF/m)
• Load controller X5-03	Max. 20 m (100 pF/m)
• Load controller X64 (24 mA)	Max. 20 m (100 pF/m)
• Safety loop / burner flange (total)	Max. 20 m (100 pF/m)
• External lockout reset button	Max. 20 m (100 pF/m)
• Safety valve	Max. 20 m (100 pF/m)
• Load output ¹⁾	Max. 10 m (100 pF/m)
• VSD control ¹⁾²⁾	Max. 3 m (100 pF/m)
• Speed input	Max. 3 m (100 pF/m)
• Fuel valve V1 / V2 / V3	Max. 3 m (100 pF/m)
• Pilot valve	Max. 3 m (100 pF/m)
• Ignition transformer	Max. 3 m (100 pF/m)
• Other lines	Max. 3 m (100 pF/m)

¹⁾ Do not run the cable together with other cables. If not observed, hum voltage might cause electromagnetic interference

²⁾ Shorter cable length due to closed control loop

Specification as per EN 60730-1:2016

Type of shutdown or interruption of each circuit

Shutdown with microswitch 1-pole

Mode of operation Type 2 B

4.1.5 Cross-sectional areas

The cross-sectional areas of the mains power lines (L, N, and PE) and, if required, the safety loop (safety limit thermostat, water shortage, etc.) must be sized for rated currents according to the selected external primary fuse.

The cross-sectional areas of the other cables must be sized in accordance with the internal unit fuse (max. 6.3 AT).

Min. cross-sectional area	0.75 mm ² (single-core or multi-core as per VDE 0100)
---------------------------	--

Cable insulation must meet the relevant temperature requirements and environmental conditions.

Fuses (F1) used inside the LMV37.4	6.3 AT (IEC 60127-2:2014)
------------------------------------	---------------------------

4.1.6 Connections of actuators

The ready connected actuator cables must not be extended.

4.2 Signal cable AGV50 from AZL2 → BC interface

Signal cable	Color white Unshielded Conductor 4 x 0.141 mm ² With RJ11 plug
Cable length	
• AGV50.100	1 m
• AGV50.300	3 m
Location	Under the burner hood (extra measures required for SKII EN 60730-1:2016)

4.3 Environmental conditions

Storage	EN 60721-3-1:1997
Climatic conditions	Class 1K3
Mechanical conditions	Class 1M2
Temperature range	-20...+60 °C
Humidity	<95 % r.h.
Transport	EN 60721-3-2:1997
Climatic conditions	Class 2K2
Mechanical conditions	Class 2M2
Temperature range	-30...+60 °C
Humidity	<95 % r.h.
Operation	EN 60721-3-3:1995 + A2:1997
Climatic conditions	Class 3K3
Mechanical conditions	Class 3M3
Temperature range	-20...+60 °C
Humidity	<95 % r.h.
Installation altitude	Max. 2,000 m above sea level



Caution!

Condensation, formation of ice and ingress of water are not permitted!

4.4 Flame detector

4.4.1 Ionization probe

For continuous operation!

No-load voltage at ION terminal (X10-05 pin 2)	Approx. U_{Mains}
---	----------------------------



Caution!
The ionization probe must be protected against electric shock hazard!

Short-circuit current	Max. AC 1 mA
Required detector current	Min. DC 2.3 μA , flame display approx. 30%
	When the more sensitive flame supervision is activated, the required detector current is halved (see chapter <i>Flame detection sensitivity</i>).
Possible detector current	Max. DC 12...30 μA , flame display approx. 100 %
Max. perm. length of detector cable (laid separately)	3 m (wire-ground 100 pF/m)



Warning!
Simultaneous operation of QRA and ionization probe is not permitted!



Note

The higher the detector cable's capacitance (cable length), the more voltage at the ionization probe, and thus the detector current, drops. Long cable lengths plus very highly resistive flames might necessitate low-capacitance detector cables (e.g. ignition cable). In spite of technical measures taken in the circuitry aimed at compensating potential adverse effects of the ignition spark on the ionization current, it must be made certain that the minimum detector current required is already reached during the ignition phase. If this is not the case, the connections on the primary side of the ignition transformer must be changed and/or the electrodes relocated.

Threshold values when flame is supervised by an ionization probe:

- Start prevention (extraneous light) Intensity of flame (parameter 954) $\geq 18\%$
- Operation Intensity of flame (parameter 954) $> 24\%$

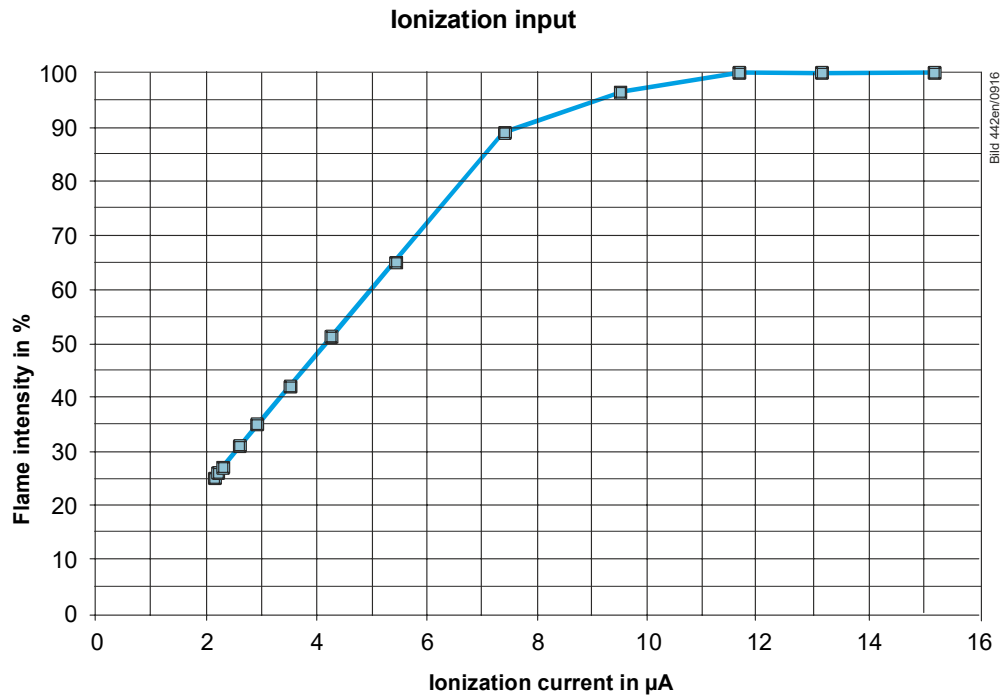

Figure 5: Ionization input at AC 120 V / AC 230 V

Measuring circuit for
detector current
measurement

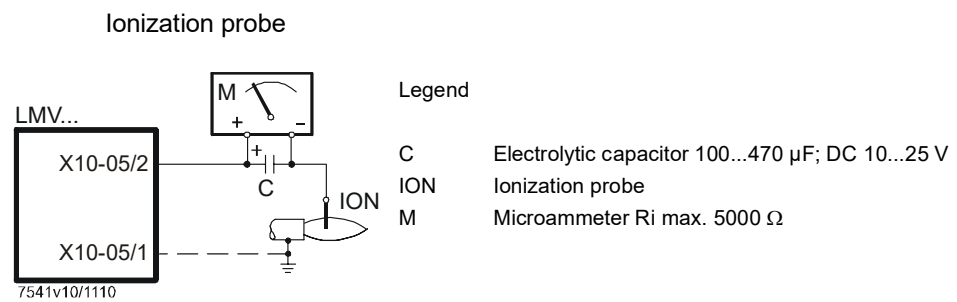

Figure 6: Measuring circuit for ionization probe

4.4.2 UV flame detectors QRA2 / QRA4 / QRA10



Caution!

If QRA2-UV tubes / QRA4-UV tubes / QRA10-UV tubes are used for flame supervision on the LMV37.4, it must be ensured that the LMV37.4 is permanently connected to power (DIN EN 298), thus enabling the LMV37.4 to detect flame detector failures during startup and shutdown.

Generally, the LMV37.4 works with QRA flame detectors in intermittent operation.

For technical data, refer to Data Sheet N7712 covering QRA2 / QRA10 UV flame detector!

For technical data, refer to Data Sheet N7711 covering QRA4 UV flame detector!

Operating voltage	Max. 350 V peak
Required detector current in operation	Min. 30 μ A
	When the more sensitive flame supervision is activated, the required detector current is halved (see chapter <i>Flame detection sensitivity</i>).
Possible detector current in operation	Max. 600 μ A
Permissible length of flame detector cable normal cable (laid separately)	Max. 6 m
Threshold values when flame is supervised by QRA:	
• Start prevention (extraneous light)	Intensity of flame (parameter 954) \geq 18%
• Operation	Intensity of flame (parameter 954) $>$ 24%

Measuring circuit for detector current measurement

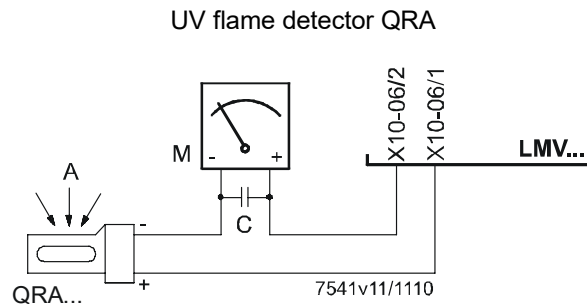

Figure 7: Measuring circuit QRA

Legend

- A Incidence of light
- C Electrolytic capacitor 100...470 μ F; DC 10...25 V
- M Microammeter R_i max. 5000 Ω



Warning!

- Input QRA is not short-circuit-proof!
Short-circuits of X10-06 pin 2 against earth can destroy the QRA input
- Simultaneous operation of QRA and ionization probe is not permitted!

4.4.3 Photoresistive flame detectors QRB1 / QRB3

No-load voltage at QRB1/QRB3 terminal (X10-05 pin 3)	Approx. DC 5 V
Max. perm. length of QRB1/QRB3 detector cable (laid separately)	3 m (wire – wire 100 pF/m)



Note

A detector resistance of $R_F < 500 \Omega$ is identified as a short-circuit and leads to safety shutdown in operation as if the flame had been lost.

For this reason, before considering the use of a highly sensitive photoresistive detector (QRB1B or QRB3S), it should be checked whether this type of flame detector is indeed required! Increased line capacitance between QRB1/QRB3 connection and mains live wire L has an adverse effect on the sensitivity and increases the risk of damaged flame detectors due to overvoltage. Always run detector cables separately!

Threshold values when flame is supervised by QRB1/QRB3:

Start prevention (extraneous light) with R_{QRB}	$< 400 \text{ k}\Omega$ Intensity of flame $\geq 10\%$
Operation with R_{QRB}	$< 230 \text{ k}\Omega$ Intensity of flame $> 16\%$
Short-circuit detection with R_{QRB}	$< 0.5 \text{ k}\Omega$

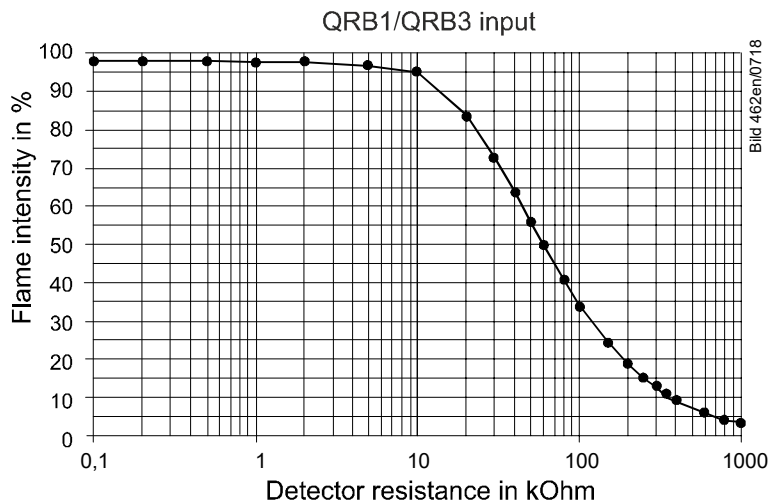

Figure 8: QRB1/QRB3 input at AC 230 V

A flame detector resistance of $R_F < 500 \Omega$ is identified as a short-circuit and leads to safety shutdown in operation, like in the case of loss of flame.



Note

The maximum display intensity is limited to approx. 40% on the QRB1 / QRB3 for system-specific reasons.

4.4.4 Yellow flame detector QRB4

Open-circuit voltage at terminal QRB4 (X10-05 pin 3)	Approx. 5 V DC
Permissible length of QRB4 detector cable (laid separately)	3 m (wire to wire 100 pF/m)
Threshold values when flame is supervised by QRB4	
Start prevention (extraneous light)	Flame intensity (parameter 954) $\geq 10\%$
Operation	Flame intensity (parameter 954) $> 16\%$



Note!

In the case of the QRB4, the maximum intensity display is limited to approximately 40% due to the system (parameter 954).



Note!

Connection of QRB4 cables!

Blue cable of QRB4 to terminal X10-05 pin 4.
Black cable of QRB4 to terminal X10-05 pin 3.
Otherwise, the QRB4 will not work.

4.4.5 Blue-flame detectors QRC

Check the intensity of flame with the AZL2.

For system-specific reasons, the display of maximum flame intensity by the AZL2 is limited to approx. 55%.



Caution!

Flame detectors QRC are only suited for AC 230 V operation.

Start prevention (extraneous light) with IQRC	Ca. 15 μ A, display approx. 10 % Intensity of flame (parameter 954)
Operation with IQRC	Ca. 25 μ A, display approx. 16 % Intensity of flame (parameter 954)

	Required detector current (with flame)	Permissible detector current (without flame)	Typical detector current (with flame)
QRC	Min. 70 μ A	Max. 5,5 μ A	100 μ A

The values given in the table above only apply under the following conditions:

- Mains voltage AC 230 V
- Ambient temperature 23 °C

Measuring circuit for
detector current
measurement

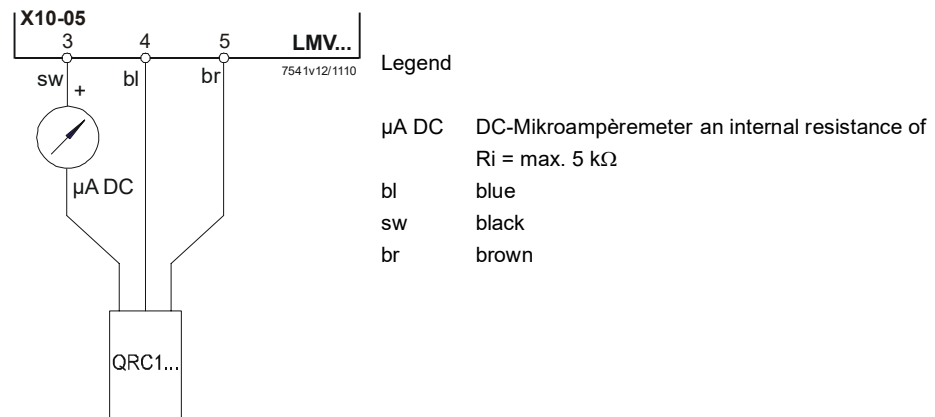

Figure 9: Measuring circuit QRC

5 Dimensions

5.1 LMV37.4

Dimensions in mm

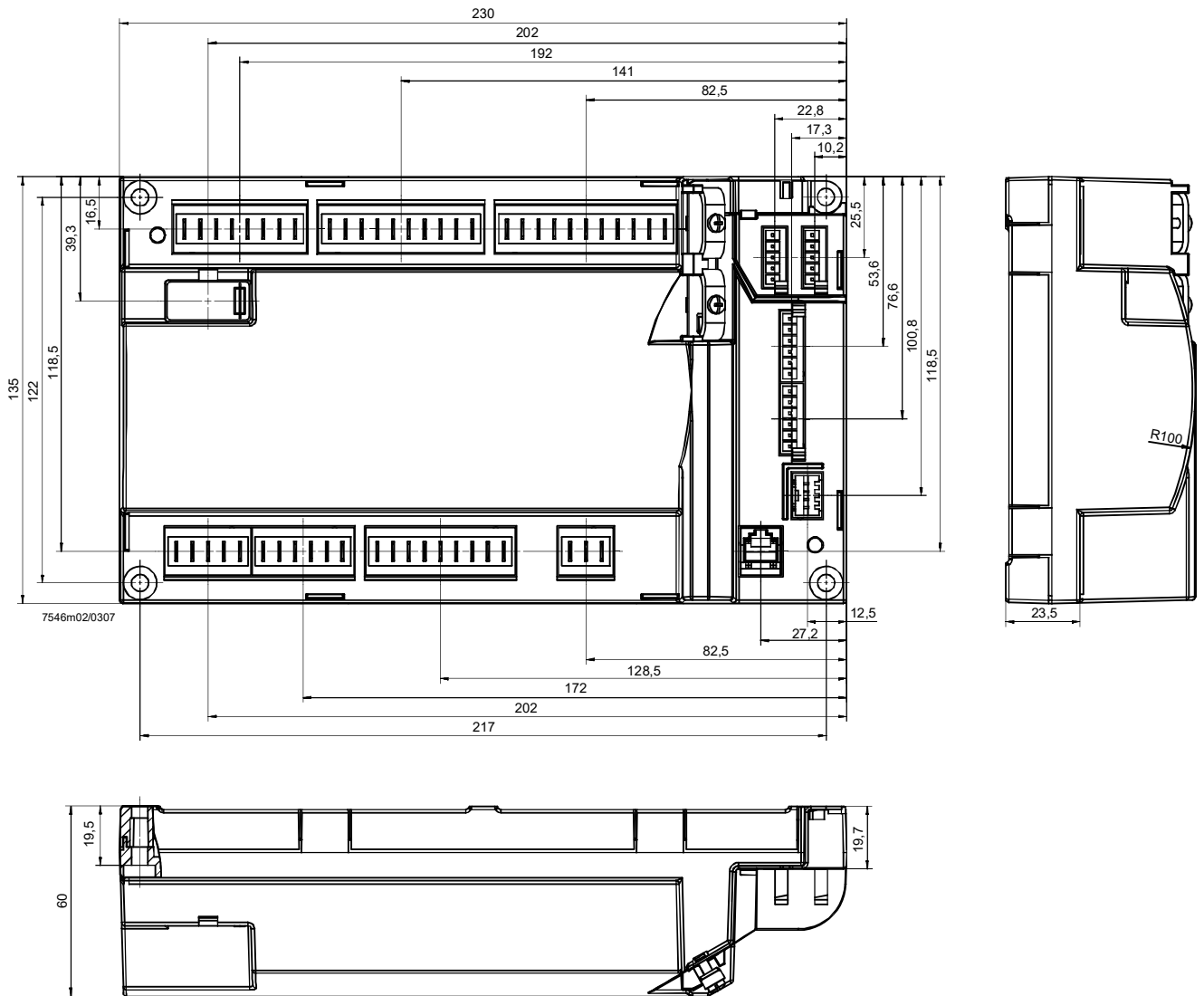

Figure 10: Dimension LMV37.4

6 Display and diagnostics

Transmission of operating states, fault status messages and detailed service information via:

BCI communication via the integrated RJ11 jack to the AZL2 or via an additional OCI410 interface to the ACS410 PC software.

Communication / parameterization

AZL2

The AZL2 offers ease of operation, parameterization and targeted diagnostics via features menu-driven operation. When making diagnostics, the display shows operating states, the type of error and startup meter reading. Passwords protect the different parameter levels of the burner / boiler manufacturer and heating engineer against unauthorized access.

ACS410 PC software

The ACS410 PC software offers straightforward operation, convenient readout of settings and operating states, parameterization, trend recordings, and targeted diagnostics of the LMV37.4. To achieve this, the OCI410 interface with the LMV37.4 is connected to the PC. In turn, the OCI410 interface is connected to the integrated RJ11 jack and is used for BCI communication. The OCI410 is available separately.

7 Basic unit LMV37.4

7.1 Description of inputs and outputs

This chapter covers the key features of the LMV37.4 inputs and outputs. For exact use of the inputs and the activation of outputs, refer to chapter *Sequence diagrams*.

Flame signal input and flame detector X10-05 and X10-06

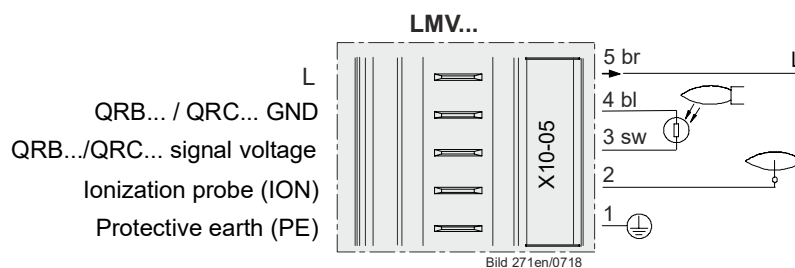

Figure 11: Flame signal input X10-05

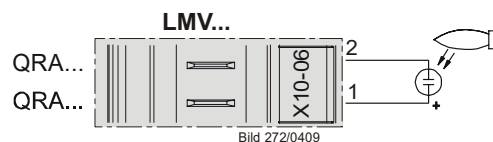

Figure 12: Flame signal input X10-06

Connection choices:

- Ionization probe
- QRA2 / QRA10
- QRA4
- QRB
- QRC

7.2 Flame detectors

For display of the flame on the AZL2, the following general conditions apply:

- Display is subject to various component tolerances, which means that deviations of $\pm 10\%$ can occur
- Note that, for physical reasons, there is no linear relationship between flame display and detector signal values

The LMV37.4 can be used with different types of flame detectors. For the correct use of flame detectors, refer to chapter *Sequence diagrams*.

The flame detector used must be correctly parameterized.



Caution!
Only ionization probes are suited for continuous operation!

In the hardware of the LMV37.4, the flame signals are subdivided into 2 groups (group 0 covering the QRB and QRC, and group 1 covering ionization and the QRA). The flame detector for gas is selected via parameter 221, that for oil via parameter 261.

No.	Parameter
221	Gas: Active detector flame evaluation 0 = QRB / QRC 1 = ION / QRA
261	Oil: Active detector flame evaluation 0 = QRB / QRC 1 = ION / QRA

7.2.1 Loss of flame

In the event of loss of flame, a safety shutdown will be initiated followed by a restart if required. A restart counter can be used to select after how many losses of flame a lockout should be initiated (see chapter *Restart counter*).

Error code	Diagnostic code	Meaning for the LMV37.4
7	0	Loss of flame

No.	Parameter
186	Software drop out delay time of flame signal (100 ms) Index 0 = QRB / QRC (0 = deactivated, >1 = activated) Index 1 = ION / QRA (0 = deactivated, >3 = activated) (only 200 ms-steps)
194	Restart limit value: No flame at end of safety time 1 = no restart 2...4 = 1...3 restarts Recharging time: Entering into operation
240 280	Restart limit value: Loss of flame 1 = no restart 2 = 1 restart Recharging time: After the <i>Operation</i> phase



Caution!
The response time of the flame detector leads to an extension of the second safety time! This must be taken into consideration when designing the burner!

7.2.2 Extraneous light

Extraneous light in standby mode (phase 12) leads to start prevention, followed by a restart. Extraneous light during the prepurge phase results in immediate lockout. If extraneous light occurs during the shutdown phase, the LMV37.4 switches to the safety phase.

A single restart is permitted. This means a lockout takes place if the error occurs again during the next shutdown.

Error code	Diagnostic code	Meaning for the LMV37.4
4	0	Extraneous light during startup
	1	Extraneous light during shutdown
	2	Extraneous light during startup – start prevention

7.2.3 No flame at the end of safety time

If no flame is established by the end of the first safety time, the unit initiates lockout.

Error code	Diagnostic code	Meaning for the LMV37.4
2	1	No flame at end of the first safety time
	2	No flame at end of the second safety time

7.2.4 Flame intensity

The flame's intensity can be displayed.
It is standardized from 0 to 100%.

No.	Parameter
954	Intensity of flame



Note

Also refer to chapter *Intensity of flame during curve settings*.

7.2.5 Supervision of flame detector

Error code	Diagnostic code	Meaning for the LMV37.4
93	3	Short-circuit of flame detector

At the QRB / QRC flame detector's input, the LMV37.4 checks the detector for short-circuits in operation.

7.2.6 Flame detection sensitivity

For applications with a high degree of modulation (e.g., 1:15 / 1:20), it may be necessary to increase the flame detection sensitivity. This can be carried out via parameter 197 for flame detection with ionization probe or UV flame detector QRA. The ignition (phases 40...52) always takes place with standard flame sensitivity. This means that the ignition load must be set so that the burner ignites reliably with regular flame sensitivity. It is also possible to deactivate the more sensitive flame detection for the load range above the ignition point (default setting curve point P4, i.e., 50% of the theoretical load of the LMV37.4).

No.	Parameter
197	Setting the flame signal sensitivity of the ionization probe / QRA 0 = standard 1 = approx. twice as high sensitivity
198	Maximum output for high flame sensitivity 2 = no maximum output for high flame sensitivity 3...9 = deactivation of the high flame sensitivity from the curvepoint P3...P9

7.3 Digital inputs

In the case of digital inputs that are switched in home run (phase 10) or preignition (phase 38), there is a maximum wait time defined in parameter 217. If no signal is detected after the maximum wait time has passed, a lockout will occur.

No.	Parameter
217	Maximum wait time for detecting a detector signal or pressure switch signal (e.g., home run, preignition)

7.3.1 Safety loop X3-04 pin 1 and 2

Input for connection of the safety loop. When any of the series-connected contacts included in the loop opens, power supply to the fuel valves, the fan and the ignition equipment is instantly cut.

The safety loop includes the following components:

- External burner switch (ON / OFF)
- Safety limiter / safety pressure limiter
- External control thermostat and / or pressurestat, if required
- Water shortage switch



Note
Pressure switch-max when using POC via X5-02.

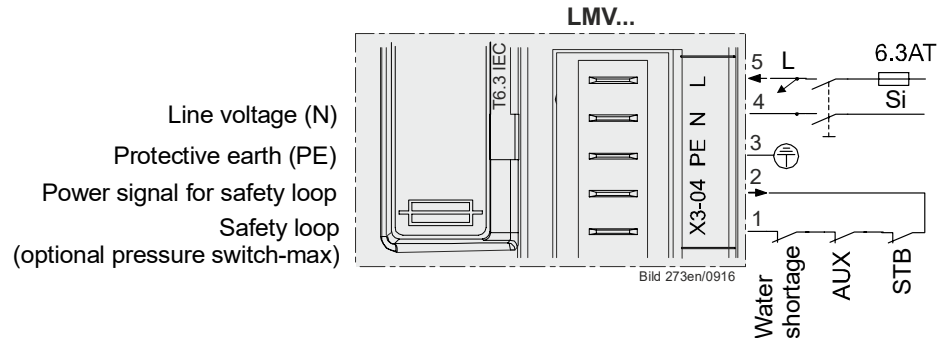

Figure 13: Safety loop X3-04

For diagnostic purposes, the contacts of the components included in the safety loop and the burner flange contact are combined for delivering the safety loop signal. If there is no such signal, the system initiates safety shutdown in any event.

If, with *Load controller ON*, there is no signal from the safety loop (start prevention), error code 22 is translated to text display **OFF S** (S = safety loop) and the numerical value appears in the error history.

Error code	Diagnostic code	Meaning for the LMV37.4
22 OFF S	0	Safety loop/burner flange Open

A restart counter can be parameterized for the input. The restart counter can be used to set the number of errors permitted until lockout occurs (see chapter *Restart counter*).

No.	Parameter
215	Restart limit value: Safety loop 1 = no restart 2...15 = 1...14 restarts 16 = continuous restart Recharging time: Every 24 hours



Attention!
In the safety loop, temporarily (<1 s) switching contacts must not be wired (switch or other)!

7.3.2 Burner flange X3-03, pin 1 and 2

End switch burner flange (component of safety loop).

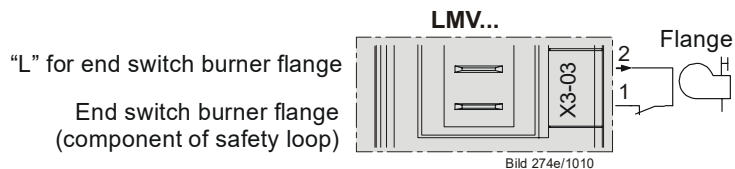

Figure 14: Burner flange X3-03

For error diagnostics and parameters, refer to chapter *Safety loop*.

7.3.3 Input for external load controller (ON / OFF) X5-03, pin 1

When the external control loop is closed, the internal input message «Heat request» is generated.

A heat request exists when the external load controller signal is pending and, depending on the configuration, a load controller calls for heat (refer to chapter *Connection of load controllers*).

When there are no more requests for heat, the burner shuts down. The fuel valves are closed, either immediately when the timer has elapsed, or when the low-fire position is reached, depending on the parameter settings (refer to chapter *End of operating position*).



Note

Burner startup takes place only when this contact is closed.

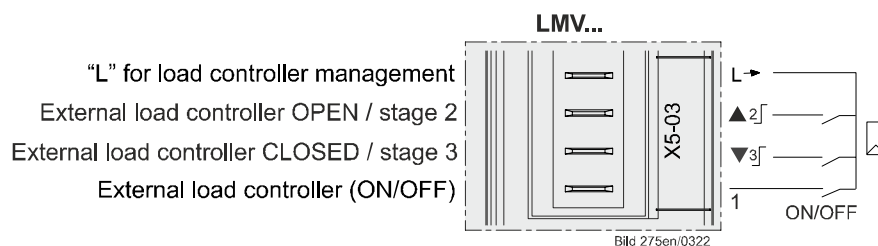

Figure 15: Inputs for external load controller ON / OFF X5-03

7.3.4 Inputs X5-03 pin 2 and 3 (Open / Close or stage 2 / stage 3)

Inputs for connection of an external load controller with contact outputs (refer to chapter *External load controller via contacts X5-03, pin 2 and 3*).

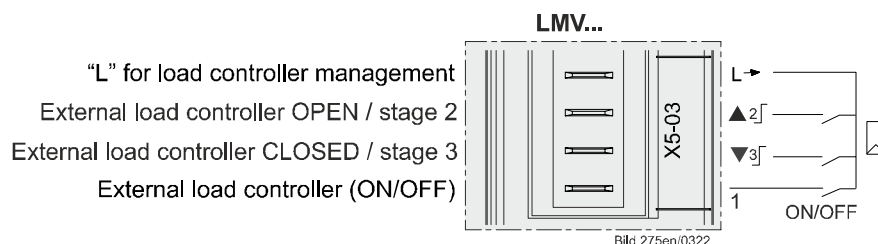

Figure 16: Inputs external load controller Open / Close X5-03



Note!

When the *Switching back to pilot* function (parameter 191) is used, the load controller contacts are not available (refer to chapter *Switching back to pilot*).

7.3.5 Air pressure switch X3-02

Input for connection of an air pressure switch. Air pressure is anticipated when the fan is switched on. If there is no air pressure signal, the system initiates lockout. The air pressure switch must have an NO contact.

If no air pressure switch is required (e.g. when firing on oil), a wire link to the fan output must be fitted (between X3-02, pin 1, and X3-05, pin 1).



Caution!

The OEM must check to see whether the burner can be operated without air pressure switch. This may necessitate a special approval, depending on the type of application.

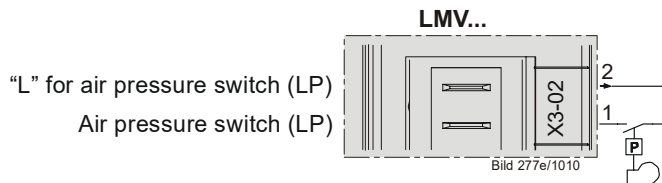

Figure 17: Air pressure switch X3-02

No.	Parameter
235	Gas: Air pressure switch 1 = active 2 = active, except phase 60...66 / 70...72 (pneumatic operation only)

Error code	Diagnostic code	Meaning for the LMV37.4
3	0	Air pressure off
	1	Air pressure on
	4	Air pressure on – start prevention

A restart counter can be parameterized for the input. The restart counter can be used to set the number of errors permitted until lockout occurs (see chapter *Restart counter*).

No.	Parameter
196	Restart limit value: Air pressure failure 1 = no restart 2 = 1 restart 3 = 2 restarts Recharging time: At end of shutdown / 24 hours of continuous operation

7.3.6 Gas pressure switch valve proving – or heavy oil direct start X9-04

Input for connection of *Pressure switch valve proving* X9-04. The input is active only when operating on gas and when valve proving is activated (refer to chapter *Program sequence*).

No.	Parameter
241	Gas: Execution valve proving 0 = no valve proving 1 = valve proving on startup 2 = valve proving on shutdown 3 = valve proving on startup and shutdown

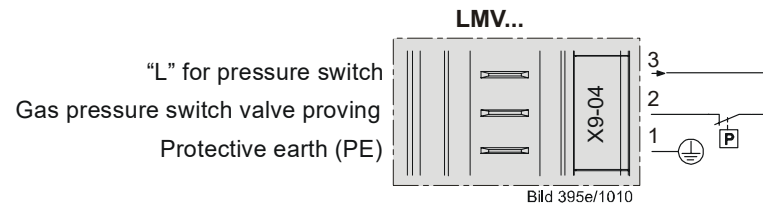

Figure 18: Gas pressure switch valve proving X9-04

Pressure switch valve proving

Input for connection of valve proving with a specific pressure switch. The input is active only when firing on gas and when valve proving is activated.

Error code	Diagnostic code	Meaning for the LMV37.4
12	81	Fuel valve V1 leaking
	83	Fuel valve V2 leaking



Note

When using configuration *Valve proving via gas pressure switch-min*, it is not possible to use the input for *Start release gas*.

Heavy oil direct start

When firing on heavy oil, input X9-04 is used for the *heavy oil direct start* signal. Parameter 286 can be used to define the time of the evaluation; parameter 287 to define the maximum waiting time for heavy oil circulation.

No.	Parameter
286	Oil: Evaluation of heavy oil direct start 0 = only start signal in phase 38 1 = evaluation in phase 38...62
287	Oil: Maximum time until heavy oil start signal

Error code	Diagnostic code	Meaning for the LMV37.4
23	2	Heavy oil direct start

A restart counter can be parameterized for the input. The restart counter can be used to set the number of errors permitted until lockout occurs (see chapter *Restart counter*).

No.	Parameter
195	Restart limit value: Heavy oil direct start 1 = no restart 2...15 = 1...14 restarts 16 = continuous restart Recharging time: At end of shutdown

7.3.7 Gas / oil pressure switch-min, start release gas X5-01

Input for connection of a pressure switch-min for gas or oil: If the plant does not require a pressure switch-min, a wire link must be fitted between pin 2 and 3.

Gas pressure switch-min

The LMV37.4 enables parameterization of which gas train position the gas pressure switch-min is mounted on. This also influences the time of the input evaluation.

No.	Parameter
236	Gas: Input pressure switch-min 1 = pressure switch-min before fuel valve V1 (default setting) 2 = valve proving (between fuel valve V1 and fuel valve V2) via pressure switch-min 3 = pressure switch-min after fuel valve V2

In all types of gas trains, the minimum gas pressure is expected from phase 22 in the default setting (value 1).

If no gas pressure is detected when the maximum time (parameter 214) has elapsed, the gas shortage program is started (refer to chapter *Gas shortage program*).

If value 2 is set, the gas shortage check only takes place in phase 39 or in conjunction with a potential valve proving as part of commissioning.

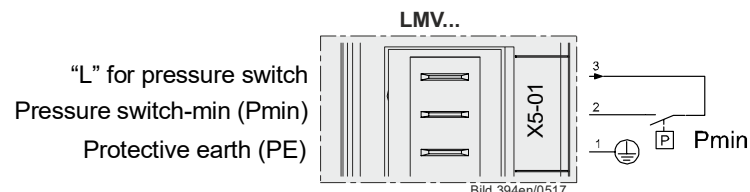

Figure 19: Gas pressure switch-min / oil pressure switch-min X5-01



Caution!

The OEM must check to see whether the burner can be operated without pressure switch-min. This may necessitate a special approval, depending on the type of application.

No.	Parameter
214	Maximum time to start release

During the safety times, the signal received from pressure switch-min is only assessed after a certain period of time in order to ignore the pressure shocks that occur the moment the valves open. The time to elapse for signal assessment can be parameterized.

No.	Parameter
229	Gas: Time to respond to pressure faults in the first and second safety time

If the gas pressure fails, at least a shutdown will be initiated.

Error code	Diagnostic code	Meaning for the LMV37.4
20	0	Pressure switch-min No minimum gas pressure
20	1	Gas shortage start prevention
23	0	Pressure switch-min No minimum gas pressure
23	1	Gas shortage start prevention

A restart counter can be parameterized for the input. The restart counter can be used to set the number of errors permitted until lockout occurs. The restart counter also functions for the gas shortage program (see chapter *Restart counter*).

No.	Parameter
223	Restart limit value: Gas pressure switch-min 1 = no restart 2...15 = 1...14 restarts 16 = continuous restart Recharging time: After the <i>Operation</i> phase

Start release gas

If, at the same time, the input is used as a start release input (e.g. for an air supply damper), it can be connected in series with the pressure switch.

When selecting *Valve proving via pressure switch-min* (parameter 236), function *Start release gas* is not supported.

No.	Parameter
236	Gas: Input pressure switch-min 1 = pressure switch-min before fuel valve V1 (default setting) 2 = valve proving (between fuel valve V1 and fuel valve V2) via pressure switch-min 3 = pressure switch-min after fuel valve V2

Oil pressure switch-min

In all types of oil trains, the minimum oil pressure is expected from phase 38. If no oil pressure is detected or the oil pressure fails afterward, a lockout will occur.

Error code	Diagnostic code	Meaning for the LMV37.4
20	0	Pressure switch-min No min. gas / oil pressure
20	1	Gas shortage start prevention

During the safety times, the signal from pressure switch-min is only assessed after a certain period of time in order to ignore the pressure shocks that occur the moment the valves open. The time to elapse for signal assessment can be parameterized.

No.	Parameter
269	Oil: Time to respond to pressure faults in the first and second safety time

7.3.8 Setting the time for making the pressure switch test

For oil pressure switch-min, the point in time after which the evaluation is made can be set via parameter 276 (active from phase 38 or from the safety time).

No.	Parameter
276	Oil: Input pressure switch-min 1 = active from phase 38 2 = active from safety time

7.3.9 Gas / oil pressure switch-max / or POC contact, start release oil / additional speed-dependent air pressure switch X5-02

Input for connection of a pressure switch-max for gas or oil: The pressure switch must have an NC contact, which means that the contact opens when the adjusted maximum pressure is exceeded. If the plant does not require a pressure switch-max, a wire link must be fitted between pin 2 and 3.



Caution!

The OEM must check to see whether the burner can be operated without pressure switch-max. This may necessitate a special approval, depending on the type of application.

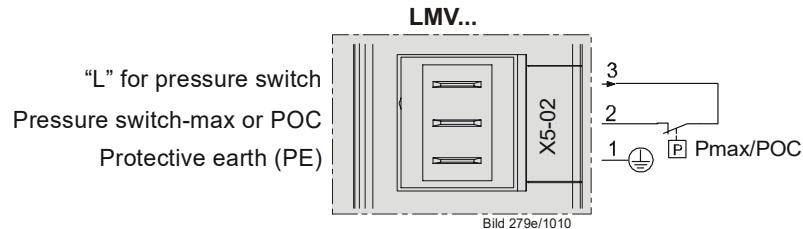

Figure 20: Gas / oil pressure switch-max or POC X5-02

The connection facility can also be used as POC (proof of closure) (refer to chapter *Sequence diagrams*).

No.	Parameter
237	Gas: Input pressure switch-max / POC 1 = pressure switch-max 2 = POC 3 = pressure switch valve proving 4 = additional speed-dependent air pressure switch



Note

If the input is used for POC or for pressure switch, pressure switch-max can be included in the safety loop. In that case, pressure switch-max must not be fitted between the valves, but downstream from them.

Gas pressure switch-max

In all types of gas trains, the maximum gas pressure is monitored from phase 40. If the maximum gas pressure is exceeded, the system initiates lockout.

Error code	Diagnostic code	Meaning for the LMV37.4
14	0	POC open
	1	POC close
21	0	Pressure switch-max: Max. gas pressure exceeded POC: POC open (software version ≤V02.00)
	1	POC close (software version ≤V02.00)

During the safety times, the signal from pressure switch-max is only assessed after a certain period time has elapsed in order to ignore the pressure shocks that occur the moment the valves open.

No.	Parameter
229	Gas: Time to respond to pressure faults in the first and second safety time

Oil pressure switch-max

In all types of oil trains, the maximum oil pressure is monitored from phase 22. If the maximum oil pressure is exceeded after the maximum time (parameter 214) has elapsed, or during the subsequent phases, the system initiates lockout.

No.	Parameter
214	Maximum time to start release

Error code	Diagnostic code	Meaning for the LMV37.4
14	0	POC open
	1	POC close
21	0	Pressure switch-max: Max. oil pressure exceeded POC: POC open (software version \leq V02.00)
	1	POC: close (software version \leq V02.00)

During the safety times, the signal from pressure switch-max is only assessed after a certain period of time has elapsed in order to ignore the pressure shocks that occur the moment the valves open.

No.	Parameter
269	Oil: Time to respond to pressure faults in the first and second safety time

The pressure switch connection can also be used as POC (Proof of Closure) (refer to chapter *Sequence diagrams*).

No.	Parameter
277	Oil: Input pressure switch-max / POC 1 = pressure switch-max 2 = POC 3 = not used 4 = additional speed-dependent air pressure switch



Note

If the input is used for POC, pressure switch-max can be included in the safety loop. In that case, pressure switch-max must not be installed between the valves, but always downstream from them.

Start release oil

If the input is simultaneously used as a start release input, e.g. for an air supply damper, the latter can be connected in series with the pressure switch. Parameters with POC function cannot be used as start release input.

Additional speed-dependent air pressure switch

In this setting, an additional speed-dependent air pressure switch can be connected on the input.

The input is evaluated depending on the actual recorded speed. The actual speed must be identified through a speed recording process (see Chapter 12.7 Acquisition of speed).

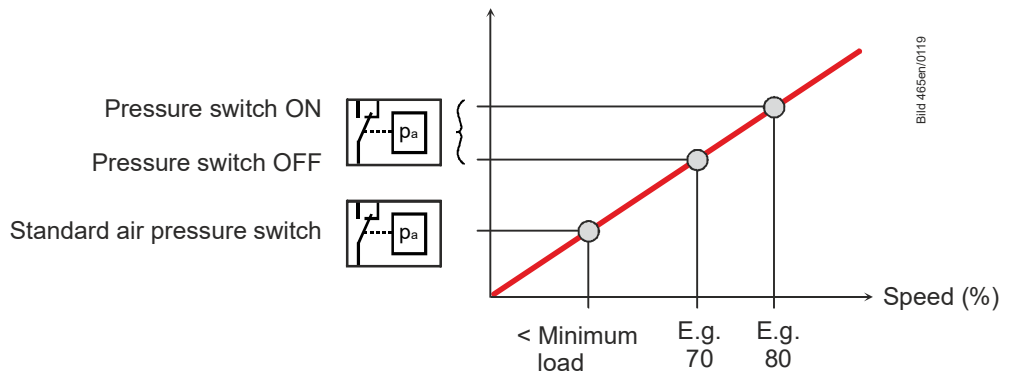

Figure 21: Additional speed-dependent air pressure switch

No.	Parameter
670	Speed air pressure switch OFF
671	Speed air pressure switch ON

The parameters 670 and 671 specify the speed limit of the VSD, from which the connected additional air pressure switch is supervised. If the current speed is higher than the ON threshold, the air pressure switch must deliver an ON signal. If the current speed is lower than the OFF threshold, the air pressure switch must deliver an OFF signal.

If the current speed is between the two speed limits, no evaluation of the air pressure switch takes place. The input is supervised in the phases from prepurging to postpurging and the valve proving phases. An incorrect signal leads to a shutdown. Intermittent operation must be activated (OEM level) if the speed-dependent air pressure switch is used as a plausibility check (resulting air pressure) for the symmetrical speed signal of a PWM fan.



Note!

If the input is configured to additional speed-dependent air pressure switches and the VSD is deactivated, no evaluation of the air pressure switch signal takes place.

Error code	Diagnostic code	Meaning for the LMV37.4
18	0	Speed-dependent air pressure switch open
	1	Speed-dependent air pressure switch closed
	128	Invalid parameterization of the speed thresholds (speed air pressure switch OFF \geq speed air pressure switch ON)

7.3.10 Reset X8-04, pin 1

Input for connection of a reset button. The LMV37.4 can be reset or manually locked via this input (refer to chapter *Reset / manual locking*).

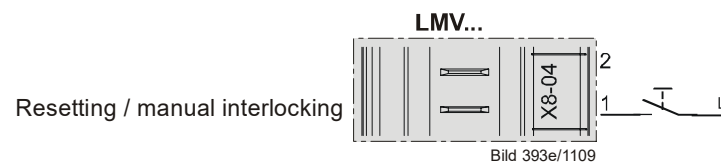

Figure 22: Reset X8-04

7.4 Digital outputs

Safety-related outputs, type SI

Using a contact feedback network, these contacts are read back by the microcomputers and checked for their correct positions.

Non-safety-related outputs, type No-SI

These outputs are not monitored by the contact feedback network and, for this reason, can only be used for non-safety-related actuators, or actuators made safe in some other form (e.g. alarm).

7.4.1 Output alarm type No-SI – X3-05, pin 2

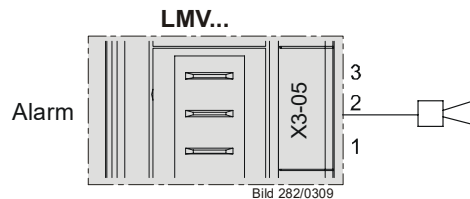

Figure 23: Output alarm X3-05

Output for connection of an alarm lamp or horn.

The output is activated when the LMV37.4 is in the lockout position (phase 00). This output can also be used to indicate start prevention.

7.4.2 Fan motor contactor type SI – X3-05, pin 1

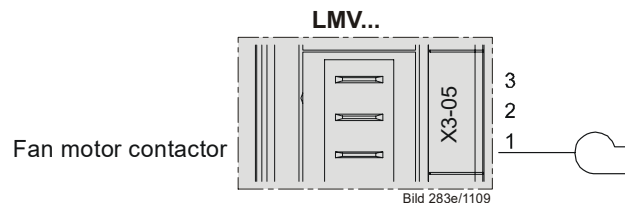

Figure 24: Fan motor contactor X3-05

Output for control of a fan power contactor (200 VA). In accordance with the sequence diagrams, the fan is on in phase 22 (refer to chapter *Sequence diagrams*).

7.4.3 Fan continuous purging X3-05, pin 3

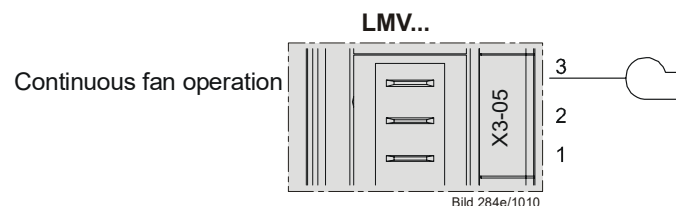

Figure 25: Continuous fan operation X3-05

If continuous purging is required, the fan motor contactor must be connected to *Continuous fan operation* – X3-05, pin 3. This terminal is tapped behind the unit fuse and the safety loop (refer to chapter *Continuous fan*).

7.4.4 Output ignition type SI (IGNITION) X4-02

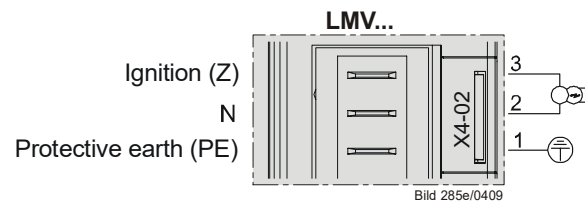

Figure 26: Output ignition X4-02

Output for the connection of ignition transformers or electronic ignition modules.

Gas

When firing on gas, ignition is switched on just prior to the first safety time in phase 38.

The preignition time in phase 38 can be parameterized.

No.	Parameter
226	Gas: Preignition time

Oil

When firing on oil, there is a choice between long and short preignition (as with gas operation from phase 38).

No.	Parameter
281	Oil: Point in time oil is ignited 0 = short preignition (phase 38) 1 = long preignition (with fan) (phase 22)

When using long preignition, ignition is switched on in phase 22, together with the fan.

In the case of short preignition, the preignition time can be parameterized.

No.	Parameter
266	Oil: Preignition time

7.4.5 Outputs fuel valves type SI V1 / V2 / V3 / PV) X8-02, X7-01, X7-02

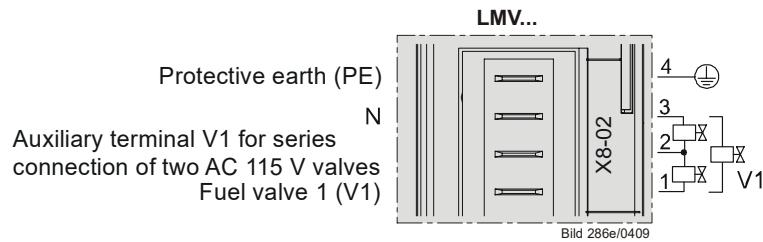

Figure 27: Output fuel valve V1 X8-02

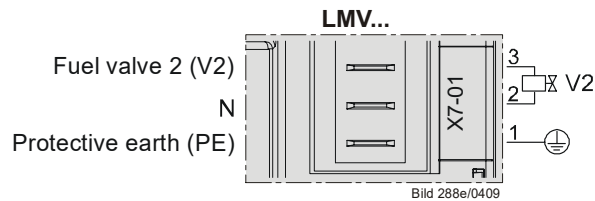

Figure 28: Output fuel valve V2 X7-01

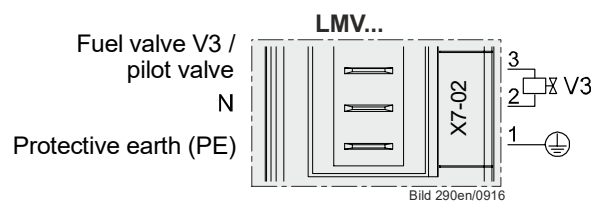

Figure 29: Output fuel valve V3 / pilot valve X7-02

Outputs for connection of the gas or oil valves, depending on the selected type of fuel train (refer to chapter *Sequence diagrams*).

7.4.6 Output safety valve type SI X6-03

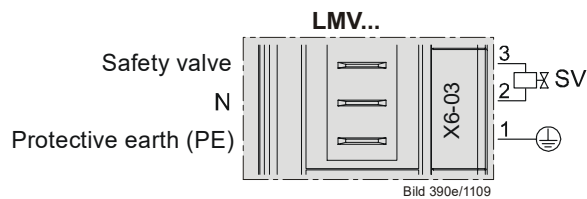

Figure 30: Output safety valve X6-03

Output for connection of an oil valve or safety valve for liquefied gas. The output is connected parallel to the output for the fan.

7.4.7 Output for operation display, type SI X8-04 pin 2

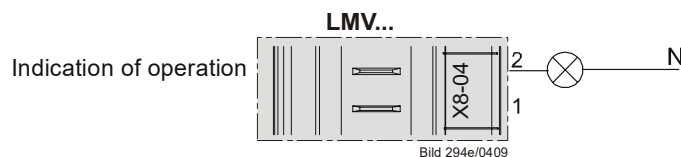

Figure 31: Output for indication of operation X8-04

Output for connection of indication of operation.



Caution!
The output is connected parallel to the fuel valve V1.

7.5 Program sequence

The program sequence is shown in the form of sequence diagrams (refer to chapter *Fuel trains*). Using a number of parameters, the program sequence can be adapted to the respective application.

7.5.1 Time parameters

Using a number of time parameters, the time characteristics of the different types of fuel trains can be matched to the requirements of the respective application.

No.	Parameter
192	<i>Switching back to pilot</i> minimum time
193	<i>Switching back to pilot</i> maximum time
211	Fan ramp up time
212	Maximum time to low-fire
213	Waiting time home run
214	Maximum time to start release
217	Max. waiting time for detecting a detector or pressure switch signal (e.g. home run, preignition)
225	Gas: Prepurge time
226	Gas: Preignition time
227	Gas: First safety time
229	Gas: Time to respond to pressure faults in the first and second safety time
230	Gas: Interval 1
231	Gas: Second safety time
232	Gas: Interval 2
233	Gas: Afterburn time
234	Gas: Postpurge time (no extraneous light test)
242	Gas: Valve proving - test space evacuating
243	Gas: Valve proving - test time atmospheric pressure
244	Gas: Valve proving - test space filling
245	Gas: Valve proving - test time gas pressure
246	Gas: Gas shortage waiting time
248	Gas: Postpurge time (abortion if load controller ON)
249	LMV37.400Ax Gas: Prepurge time (OEM)
265	Oil: Prepurge time
266	Oil: Preignition time
267	Oil: First safety time
269	Oil: Time to respond to pressure faults in the first and second safety time
270	Oil: Interval 1
271	Oil: Second safety time
272	Oil: Interval 2
273	Oil: Afterburn time
274	Oil: Postpurge time (no extraneous light test)
284	Oil: Postpurge time (abortion if load controller ON)
287	Oil: Maximum until time heavy oil start signal
288	LMV37.400Ax Oil: Prepurge time (OEM)



Caution!

The OEM or the heating engineer must make certain that the times conform to the standards covering the respective type of plant.

7.5.2 Valve proving

Valve proving is only active when firing on gas. Valve proving designed to detect leaking gas valves and, if necessary, to prevent the valves from opening or ignition from being switched on. Lockout is initiated, if required.

When performing valve proving, the gas valve on the burner side is opened first to bring the test space to atmospheric pressure. After closing the valve, the pressure in the test space must not exceed a certain level. Then, the gas valve on the mains side is opened to fill the gas pipe. After closing, the gas pressure must not fall below a certain level.

Valve proving can be parameterized to take place on startup, shutdown, or on both. The type of valve proving can be selected via parameter 236 / 237.

Recommendation:

Perform valve proving on shutdown.

No.	Parameter
236	Gas: Input pressure switch-min 1 = pressure switch-min before fuel valve V1 (default setting) 2 = valve proving (between fuel valve V1 and fuel valve V2) via pressure switch-min 3 = pressure switch-min after fuel valve V2
237	Gas: Input pressure switch-max / POC 1 = pressure switch-max 2 = POC 3 = pressure switch valve proving 4 = additional speed-dependent air pressure switch
241	Gas: Execution-valve proving 0 = no valve proving 1 = valve proving on startup 2 = valve proving on shutdown 3 = valve proving on startup and shutdown
242	Gas: Valve proving - test space evacuating
243	Gas: Valve proving - test time atmospheric pressure
244	Gas: Valve proving - test space filling
245	Gas: Valve proving - test time gas pressure



Caution!

If valve proving is parameterized to take place «on startup and shutdown», the gas valves must run through additional switching cycles. As a result, strain on the gas valves (wear) increases.



Caution!

The OEM must set the evacuation, filling and test times for atmospheric or mains pressure on every plant in compliance with the requirements of EN 1643.

It must be ensured that the 2 test times are correctly set. It is to be checked whether the gas required for the test may be fed into the combustion chamber (on the relevant application). The test times are safety-related. After a reset and in the case of aborted or prevented valve proving, the unit performs valve proving on the next startup (only when valve proving is activated). Prepurging with valve proving is active during the startup phase, even if it was deactivated.

Examples of aborted valve proving:

If the safety loop or the start prevention input for gas (containing pressure switch-min) opens during valve proving.

Valve proving – calculation of leakage rate

$$t_{\text{Test}} = \frac{(P_G - P_W) \cdot V \cdot 3600}{P_{\text{atm}} \cdot Q_{\text{Leck}}}$$

QLeck	in l/h	Leakage rate in liters per hour
PG	in mbar	Overpressure between the valves at the beginning of the test phase
PW	in mbar	Overpressure set on the pressure switch (normally 50% of the gas inlet pressure)
Patm	in mbar	Absolute air pressure (1013 mbar normal pressure)
V	in l	Volume between the valves (test volume) including valve volume and pilot pipe, if present (Gp1 mod)
tTest	in s	Test time

7.5.2.1. Valve proving with separate pressure switch X9-04

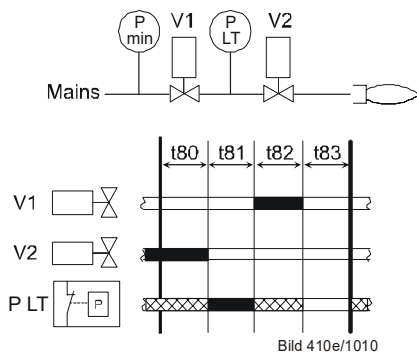

Figure 32: Valve proving with separate pressure switch

Step 1: t80 – evacuation of test space.

Gas valve on the burner side is opened to bring the test space to atmospheric pressure.

Step 2: t81 – test time atmospheric pressure.

When the gas valve has closed, the gas pressure in the test space must not exceed a certain level.

Step 3: t82 – filling of test space.

Gas valve on the mains side opens to fill the test space.

Step 4: t83 – test time gas pressure.

When the gas valve has closed, the gas pressure in the test space must not drop below a certain level.

Legend

t80	Evacuation of test space (parameter 242)
t81	Test time atmospheric pressure (parameter 243)
t82	Filling of test space (parameter 244)
t83	Test time gas pressure (parameter 245)
V...	Fuel valve
P LT	Pressure switch – valve proving
Pmin	Pressure switch-min
	Input/output signal 1 (ON)
	Input/output signal 0 (OFF)
	Input permissible signal 1 (ON) or 0 (OFF)

7.5.2.2. Valve proving via gas pressure switch-min X5-01

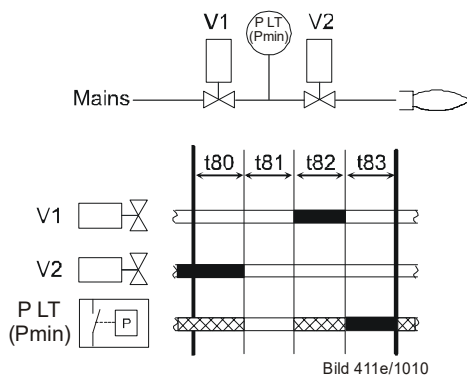

Figure 33: Valve proving via gas pressure switch-min

Step 1: t80 – evacuation of test space.

Gas valve on the burner side is opened to bring the test space to atmospheric pressure.

Step 2: t81 – test time atmospheric pressure.

When the gas has closed, the gas pressure in the test space must not exceed a certain level.

Step 3: t82 – filling of test space.

Gas valve on the mains side opens to fill the test space.

Step 4: t83 – test time gas pressure.

When the gas valve has closed, the gas pressure in the test space must not drop below a certain level.

Legend

t80	Evacuation of test space (parameter 242)
t81	Test time atmospheric pressure (parameter 243)
t82	Filling of test space (parameter 244)
t83	Test time gas pressure (parameter 245)
V...	Fuel valve
Pmin	Pressure switch-min
P LT	Pressure switch – valve proving
	Input/output signal 1 (ON)
	Input/output signal 0 (OFF)
	Input permissible signal 1 (ON) or 0 (OFF)

When making the valve proving test via gas pressure switch-min, the impact on the program sequence is as follows (see *Sequence diagram G*):

a) Valve proving on startup

In place of sampling gas pressure switch-min (gas shortage test) in phase 22, it is sampled during the time valve proving is performed at the end of the filling time.

b) Valve proving on shutdown/deactivated

Gas pressure switch-min is sampled at the end of preignition. For that purpose, a new phase 39 (test pressure switch-min) is introduced and evaluation of gas shortage is made at the end of the phase (duration of phase = filling time). In practice, this represents an *extension* of preignition by the filling time, if valve proving via gas pressure switch-min was selected.

The valve proving test can only be made via gas pressure switch-min, which must be fitted between the valves. This has an impact on the control sequence (refer to chapter *Sequence diagrams*). Valve proving is still activated via parameter 241.

No.	Parameter
241	Gas: Execution valve proving 0 = no valve proving 1 = valve proving on startup 2 = valve proving on shutdown 3 = valve proving on startup and shutdown

7.5.2.3. Lockout phase (phase 00)

The relays of the fuel valves and the safety relay (fan) are deenergized, the alarm relay is energized and lockout takes place. This means that phase 00 can only be quit via a manual reset. The time of phase 00 is unlimited.

7.5.2.4. Safety phase (phase 01)

The safety phase is an intermediate phase that is performed before a lockout. The relays for the fuel valves and the safety relay (fan) are switched off but a lockout still does not occur. The alarm relay has not been activated yet. If possible or permitted, safety checks or restart counter checks are carried out. The results of the checks determine the transition to lockout phase or standby. The time period for the safety phase is dynamic (depends on the scope of the test) but lasts no more than 30 seconds. This process aims primarily to prevent unwanted lockouts caused by EMC influences, for example.

7.5.3 Special functions during the program sequence

7.5.3.1. Reset / manual lockout

The LMV37.4 can be manually locked by simultaneously pressing the **Info** button and **any other button** on the AZL2. This function enables the operator to lock the LMV37.4 from any of the operating levels or, in other words, to trigger non-volatile lockout. Due to the system's structure, this does not represent an *Emergency OFF* function.

When making a reset, the following actions are carried out:

- Alarm relay and fault display are switched off
- The lockout position is canceled
- The LMV37.4 makes a reset and then changes to standby

There are 3 choices to reset the LMV37.4.

1. Resetting on the AZL2

If the LMV37.4 is in the lockout position, a reset can be made by pressing the **Info** button for 1...3 seconds. The function is available only when the LMV37.4 is in the lockout position. Longer or shorter pushes on the button do not produce a reset so that the system maintains the lockout position.

Error code	Diagnostic code	Meaning for the LMV37.4
167	2	Manual lockout by the AZL2

2. Resetting by pressing the button by the *Reset* connection terminal on the LMV37.4 (X8-04, pin 1)

If the unit is in the lockout position, a reset can be made by pressing the button for 1...3 seconds. Longer or shorter pushes on the button are ignored so that the LMV37.4 maintains the lockout position.

If the unit is **not** in the lockout position and the reset button is pressed for 1...6 seconds, a change to the lockout position takes place.

If this response is not desirable, it is possible to tap the supply for the reset button from the alarm output, thus achieving the same response as described above under 1.

Error code	Diagnostic code	Meaning for the LMV37.4
167	1	Manual lockout by contact

Reset without manual lockout

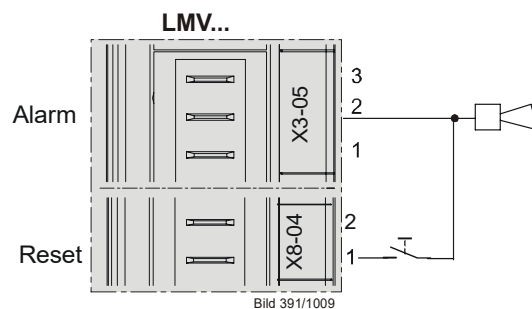

Figure 34: Without manual lockout

Reset with manual lockout

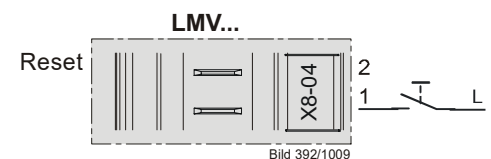

Figure 35: With manual lockout

3. Resetting via the PC software ACS410

Refer to the documentation covering the PC software ACS410 (J7352).

Error code	Diagnostic code	Meaning for the LMV37.4
167	3	Manual lockout by PC software ACS410

7.5.3.2. Alarm upon start prevention

If start prevention occurs, it is shown on the display of the AZL2.

Start prevention takes place only when a heat request is delivered **and** when one of the startup criteria is not fulfilled.

The time to elapse from start prevention to display on the AZL2 is set to a fixed value of 5 seconds.

In addition, it is possible to indicate start preventions via the alarm output. This function can be activated per parameter.

No.	Parameter
210	Alarm in the event of start prevention 0 = deactivated 1 = activated

If «Alarm in the event of start prevention» is activated via the alarm relay, start prevention and lockout can only be distinguished via the display on the AZL2. Start preventions are displayed as **Err:**, lockouts as **Loc:**.



Note

If the reset contact between terminal X8-04 pin 1 and X8-04 pin 2 on the LMV37.4 is activated during a start prevention, the LMV37.4 will be manually locked. The time between the start prevention occurring and it being signaled at the alarm contact is the same as the time it takes for the start prevention to be indicated on the AZL2.

7.5.3.3. Possible start preventions

On the normal display, error code 201 is translated to text display **OFF UPr** (UPr = unprogrammiert = not programmed); the numerical value appears in the error history.

Error code	Diagnostic code	Meaning for the LMV37.4
201 OFF UPr	1	No operating mode selected
	2...3	No fuel train defined
	4...7	No curve defined
	8...15	Standardized speed undefined
	16...31	Backup / restore was not possible
		Other start preventions:
3	4	Air pressure on – start prevention
4	2	Extraneous light during startup – start prevention
14	64	POC open – prevention of startup
21	64	POC open – prevention of startup (software version $\leq V02.00$)
22 OFF S	1	Safety loop / burner flange open – prevention of startup
83	#	Speed error VSD
97	#	Error relay supervision
	0	Safety relay contacts have welded or external power supply fed to safety relay

No.	Parameter
642	Standardized speed Index 0 = speed 1 Index 1 = speed 2 (internal monitoring) Fuel 1: Index 2 = fuel 1: Speed 1 Index 3 = fuel 1: Speed 2 (internal monitoring)
935	Absolute speed
936	Standardized speed

7.5.3.4. Restart counter

Restart counters are provided for various errors. They are used to set the number of errors permitted until lockout occurs. Lockout occurs following the final permitted error. Example: If 3 is set, a restart occurs after the first two errors and a lockout of the LMV37.4 occurs after the third error.



Note

If 16 is set, this means that infinite restarts can take place, i.e., no lockout will occur.

Functions with adjustable restart counter

No.	Parameter
194	Restart limit value: No flame at end of safety time 1 = no restart 2...4 = 1...3 restarts Recharging time: Entering into operation
195	Restart limit value: Heavy oil direct start 1 = no restart 2...15 = 1...14 restarts 16 = continuous restart Recharging time: At end of shutdown
196	Restart limit value: Air pressure failure 1 = no restart 2 = 1 restart 3 = 2 restarts Recharging time: At end of shutdown / 24 hours of continuous operation
199	Restart limit value: Actuators 1 = no restart 2 = 1 restart 3 = 2 restarts Recharging time: End of shutdown and after 24 hours of continuous operation
215	Restart limit value: Safety loop 1 = no restart 2...15 = 1...14 restarts 16 = continuous restart Recharging time: Every 24 hours
223	Restart limit value: Gas pressure switch-min 1 = no restart 2...15 = 1...14 restarts 16 = continuous restart Recharging time: After the <i>Operation</i> phase
240 280	Restart limit value: Loss of flame 1 = no restart 2 = 1 restart Recharging time: After the <i>Operation</i> phase

Error code	Diagnostic code	Meaning for the LMV37.4
2	1	No flame at the end of the first safety time
3	0	Air pressure
7	0	Loss of flame
20	0	Pressure switch-min No minimum gas / oil pressure
22 OFF S	0	Safety loop / burner flange open
23	2	Heavy oil direct start
82	#	Error during VSD's speed standardization
83	#	Speed error VSD
85	#	Referencing error ones actuators
86	#	Error fuel actuator
87	#	Error air actuator

If the adjustable restart counter values are changed, the counter is only recharged when the corresponding recharging time is reached (after power ON or after a reset).



Note

If immediate recharging shall be enforced, the LMV37.4 can be manually locked and then reset.

Functions with fixed restart counters

These counters cannot be set.

Meaning	Settings
	Basic setting
Number of restarts in the event of an error <ul style="list-style-type: none"> Relay Relay control Recharging time: End of <i>Operation</i> phase	2
Number of restarts in the event of an internal error Recharging time: After 24 hours of operation	5

Error code	Diagnostic code	Meaning
95...98	#	Error relay supervision
99...100	#	Internal error relay control

7.5.3.5. Start without prepurging (as per EN 676)

When using valve proving and 2 fuel valves of class A, prepurging is not required (conforming to EN 676).

Prepurging can be deactivated per parameter.

No.	Parameter
222	Gas: Prepurging 0 = deactivated 1 = activated

When prepurging is activated, it is performed in accordance with the adjusted prepurge time.

If not activated, it is nevertheless performed if one or several of the following conditions apply:

- Alterable lockout position
- After an off time of >24 hours
- In the event of a power failure (power-on)
- In the event of shutdown due to an interruption of gas supply (safety shutdown)

No.	Parameter
225	Gas: Prepurge time

7.5.3.6. Gas shortage program

Valve proving via gas pressure switch-min (parameter 236 = 2)

As gas pressure switch-min is located between the valves, the gas shortage test cannot be made in phase 22. Instead, when performing valve proving on startup, the gas shortage test is performed at the end of the filling time (end of phase 82).

With no valve proving on startup, the gas shortage test is made directly before first safety time is started (end of phase 39).

No.	Parameter
236	Gas: Input pressure switch-min 2 = valve proving (between fuel valve V1 and fuel valve V2) via pressure switch-min

Standard valve proving (parameter 236 = 1)

If the gas pressure is too low, startup is aborted in phase 22.

No.	Parameter
236	Gas: Input pressure switch-min 1 = pressure switch-min before fuel valve V1 (default setting)
246	Gas: Gas shortage waiting time

If gas shortage occurs with the last of the parameterized number of start attempts, the system initiates lockout.

No.	Parameter
223	Restart limit value: Gas pressure switch-min 1 = no restart 2...15 = 1...14 restarts 16 = continuous restart Recharging time: After the <i>Operation</i> phase

In that case, the LMV37.4 with gas shortage program makes a selectable number of start attempts until lockout occurs. The waiting time from one start attempt to the next is doubled each time, starting from an adjustable waiting time.

7.5.3.7. Program stop function

To simplify the burner settings in connection with commissioning and service work, the program sequence of the LMV37.4 can be stopped at the following positions:

- | | |
|------------------------------------|----|
| 1) Air damper in prepurge position | 24 |
| 2) Ignition position | 36 |
| 3) Interval 1 | 44 |
| 4) Interval 2 | 52 |

The program stops are integrated in the setting sequence when the plant is commissioned (refer to chapter *Air-fuel ratio curves – settings and commissioning*). After the initial settings, program stops can be activated on the parameter level.

No.	Parameter
208	Program stop 0 = deactivated 1 = prepurge position (phase 24) 2 = ignition position (phase 36) 3 = interval 1 (phase 44) 4 = interval 2 (phase 52)

The program stop function is maintained until manually deactivated. If the LMV37.4 halts at one of the program stops, a message appears on the display of the AZL2.

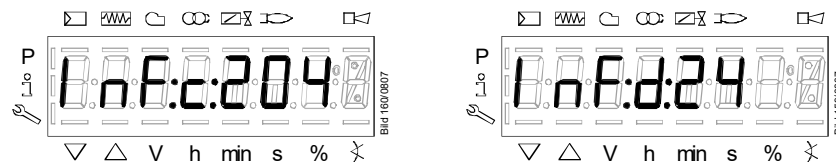

Figure 36: Message in the case of program stop

Example: **c:204** alternating with **d:24** corresponds to a program stop in the prepurge position.

7.5.3.8. Forced intermittent operation (<24 hours)

When forced intermittent operation is activated, the unit shuts down for a moment after 23 hours and 45 min of uninterrupted operation, followed by an automatic restart.

Forced intermittent operation is a standard feature.

No.	Parameter
239	Gas: Forced intermittent operation 0 = deactivated 1 = activated
279	Oil: Forced intermittent operation 0 = deactivated 1 = activated

7.5.3.9. Low-fire shutdown

To prevent the boiler from being shut down under full or nearly full load conditions, electronic fuel-air ratio control can run the burner to the low-fire position first when there is no more request for heat (refer to chapter *End of operating position*).

7.5.3.10. Continuous fan

With burners that can be damaged by heat (e.g. several burners using the same combustion chamber), continuous purging may be required. In that case, the fan operates continuously in all phases.

For that purpose, the fan motor contactor is to be connected to X3-05, pin 3, tapped after the unit fuse and the safety loop.

For checking the air pressure switch, a pressure switch relief valve must be connected to fan motor contactor X3-05, pin 1. When output X3-05, pin 1, is activated, the relief valve diverts the fan pressure to the air pressure switch and, when deactivated, ensures that no pressure is fed to the switch.

Example:

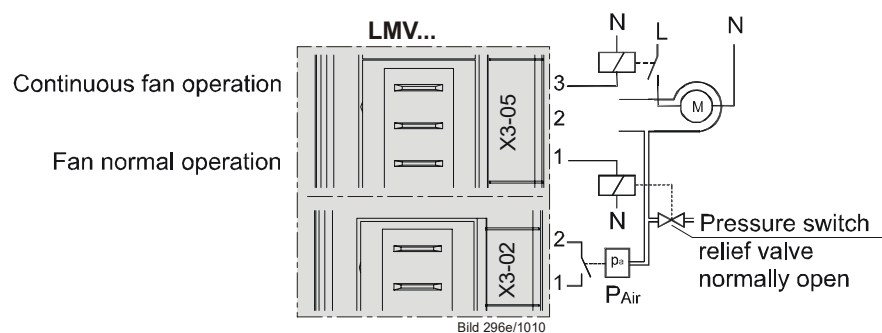

Figure 37: Continuous fan

7.5.3.11. Test function for approval of burner – loss-of-flame test (TÜV test)

The purpose of this test is to verify the detection time required in the event of loss of flame when applying for burner approval. When starting the test, the fuel valves are shut to determine the time (resolution of 0.2 seconds) until the LMV37.4 detects loss of flame.

Procedure:

- Determine the burner output at which the test shall be made, using parameter 133. If these parameters are not set, the test is carried out at the current output of the system
- Start the test by entering value 1 for parameter 124. If the burner's output was defined for the test (parameter 133), the LMV37.4 runs to that output first. To implement this function, the default value of parameter 121 (manual output) is used. This cancels any manual output that was previously active
- Now, the LMV37.4 shuts the fuel valves, leading to loss of flame
- The evaluation is made by the LMV37.4 by measuring the time the system requires from fuel valve shutdown until loss of flame is detected. Then, the required time is displayed in the form of diagnostic code **C:7** (loss of flame)

The resolution is 0.2 seconds.

Example

When the display reads **C:7 D:10**, the time required from valve shutdown to detection of loss of flame is 2 seconds (**D:10** means $10 \times 0.2 = 2$ seconds).

When the test is successfully completed, parameter 124 is reset to **0**. If unsuccessful, a negative value is delivered for diagnostic purposes and error code **150** is entered.

- -1 = invalid phase (test only possible in phase 60) – display reads **C:150 D:1**
- -2 = default output < minimum output – display reads **C:150 D:2**
- -3 = default output > maximum output – display reads **C:150 D:3**
- -4 = manual abortion (no error, start variable was manually reset to **0**) – display reads **C:150 D:4**
- -5 = timeout during TÜV test (no loss of flame after shutdown of valves within 50 seconds) – lockout **C:150 D:5**

Previously set output values at which the test shall be made (parameter 133) remain stored.

No.	Parameter
121	Manual output Undefined = automatic operation
124	Loss of flame test (TÜV test) starting (parameterized on 1) (switch off the fuel valves → loss of flame) Error diagnostic via negative value (refer to error code 150)
133	Default output at TÜV test Invalid = TÜV test at active output 20...100 = low-fire...high-fire or stage 1 / stage 2 / stage 3 P1...P3 = stage 1...stage 3

7.5.3.12. Postpurging in the lockout position

Parameter 190 can be used to move the actuators (actuators or VSD) to the postpurge position while they are in the lockout position.

No.	Parameter
190	Postpurging in lockout position 0 = deactivate (no-load position) 1 = active (postpurge position) When active, the <i>Alarm in the event of start prevention</i> function (parameter 210) is only possible to a limited extent!

Note!
 The LMV37.4 simply moves the actuators (actuators or VSD) to the postpurge position. A fan or VSD release contact cannot be controlled, as the alarm relay of the LMV37.4 cuts off the power supply to the outputs. With the *Alarm in the event of start prevention* function, an external circuit that may be present for controlling the fan / VSD release contact for postpurging in the lockout position is activated via start prevention in standby mode.

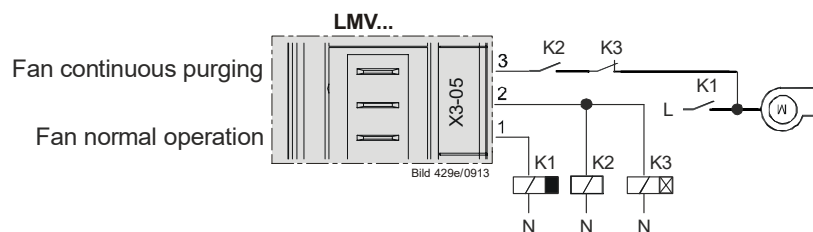

Figure 38: Application example of postpurging in the lockout position with fan but without VSD

The duration of postpurging in the lockout position can be set via the delay time of K3.

Attention!
 When the *Postpurging in the lockout position* function is used, the fan may only be powered via a contactor and must not be connected directly to LMV37.4 (X3-05 pin 1)!

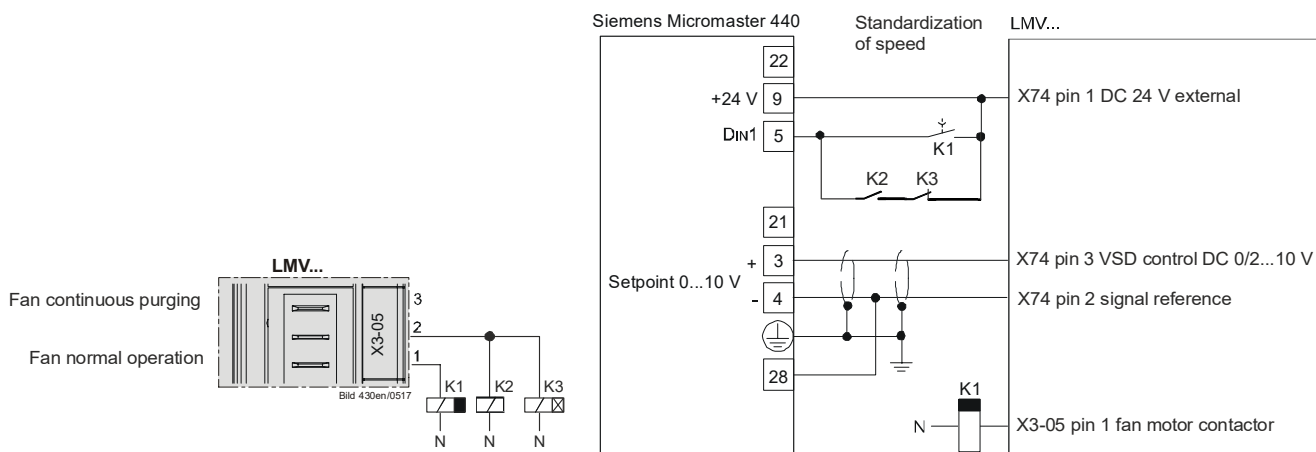

Figure 39: Application example of postpurging in the lockout position with fan and VSD release contact

The duration of postpurging in the lockout position can be set via the delay time of K3.

Attention!
 When the *Postpurging in the lockout position* function is used, the fan may only be powered via a contactor and must not be connected directly to LMV37.4 (X3-05 pin 1)!

7.5.3.13. Switching back to pilot

The function must be selected with parameter 191. This deactivates the OPEN / CLOSE load controller contacts (X5-03 pin 2 or 3). Contact X5-03 pin 2 is evaluated as the input signal for *Switching back to pilot*. The function can be started either by a low or high signal. Both the minimum and maximum dwelling time can be set for the pilot flame via time parameters.

No.	Parameter
191	<i>Switching back to pilot</i> 0 = deactivate 1 = active (low active) 2 = active (high active) Load controller contacts X5-03 are deactivated when function is active!
192	<i>Switching back to pilot</i> minimum time
193	<i>Switching back to pilot</i> maximum time



Note!

Once the OPEN / CLOSE load controller contacts have been deactivated, the analog input is the lowest-priority load controller source. The system response when the analog signal is interrupted can be performed via parameter 204 (low-fire or shutdown and start prevention).

No.	Parameter
204	Behavior if analog input is invalid (4...20 mA) 0 = deactivate default output low-fire / trim function (with warning message) 1 = safety shutdown + startup prevention 2 = deactivate default output low-fire / trim function (without warning message)

Sequence following activation of input signal in operation (phase 60) – (also refer to *Sequence diagram*):

1. Phase 64: Modulation to ignition load
2. Phase 65: Interval 2 waiting time (stabilization time)
3. Phase 66: Reactivation of ignition and pilot valve (duration of the first safety time)
4. Phase 67: Shutdown of the main valves (duration of the first safety time, including blind circuit for pressure switch-min / pressure switch-max)
5. Phase 68: Pilot mode waiting phase (pilot minimum time / pilot maximum time)

The LMV37.4 is restarted (via second safety time) when the input signal no longer exists.

Shutdown of the LMV37.4 in the event of:

- Load controller OFF
- Maximum pilot time exceeded (maximum setting 108 minutes)
- Forced intermittent operation after 24 hours

When the input signal is active during startup, the LMV37.4 waits in phase 69 (interval 1). While the switching back to pilot function is in use, the remaining time to shutdown is displayed via the maximum time in the AZL2.



Note!

A user intervention has top priority. This means that an active curve setting or preselected manual output (signaled by flashing output display) prevents the switching back to pilot function from being activated.

The restarts from the pilot waiting phase are counted in the startup counter (parameter 176).

No.	Parameter
176	<i>Switching back to pilot</i> switching cycles

RWF55 application examples:

The setting must be set to low active to use the RWF55. The load controller ON signal (X5-03 pin 1 / pin 4) is applied at RWF55 (contacts 1P and 1N). The signal for switching back to pilot (X5-03 pin 2) is connected to RWF55 (contacts 6N and 6P). Function **Ik5** must be selected at RWF55.

The output is preselected via a 4...20 mA analog signal.

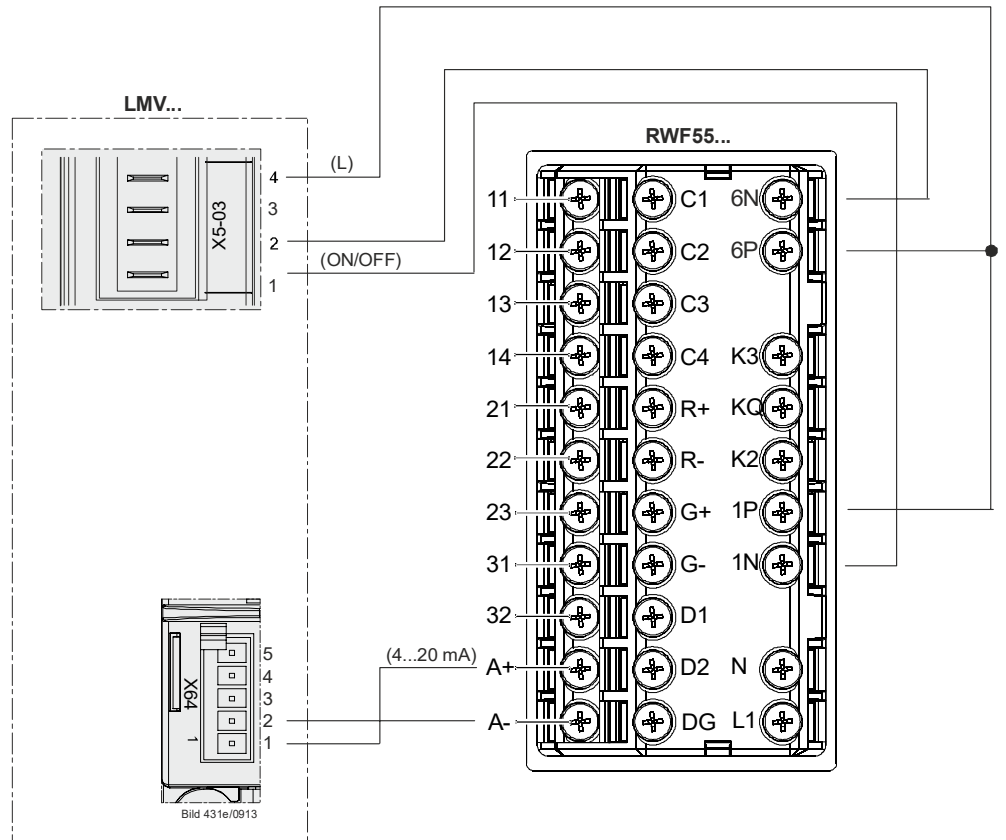

Figure 40: Wiring LMV37.4 with universal controller RWF55

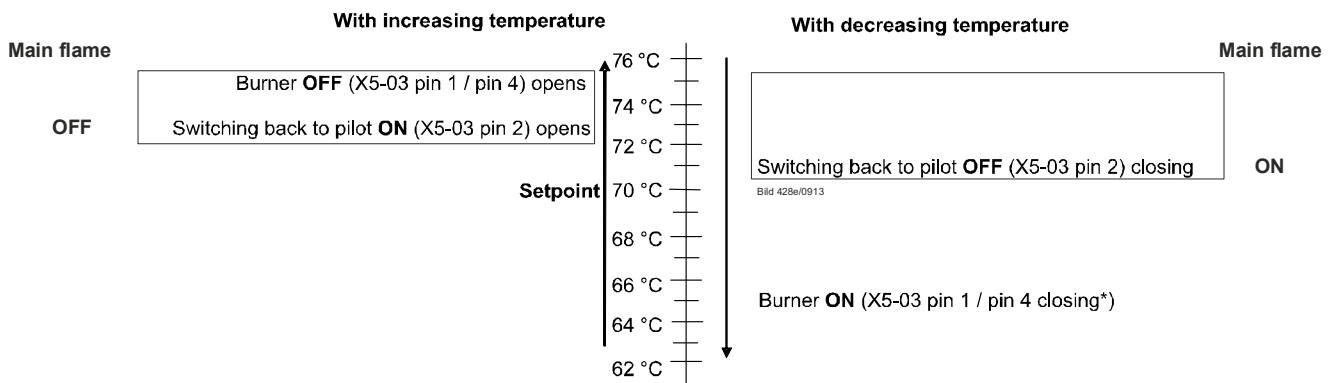

Figure 41: Switching back to pilot sequence in connection with an RWF55 universal controller

*) The burner ON threshold is only active when switching on (cold start)

The *Switching back to pilot* function is active in the marked temperature zone. If the temperature increases above the ON threshold, the *Switching back to pilot* function is activated. The main flame is shut down at the same time. If the temperature decreases in the direction of the setpoint, the *Switching back to pilot* function remains active until the temperature falls below the OFF threshold.

The main flame is switched back on.

7.6 Fuel trains (application examples)

Gas direct ignition
(Operating mode 1, 7, 14, 19, 28)

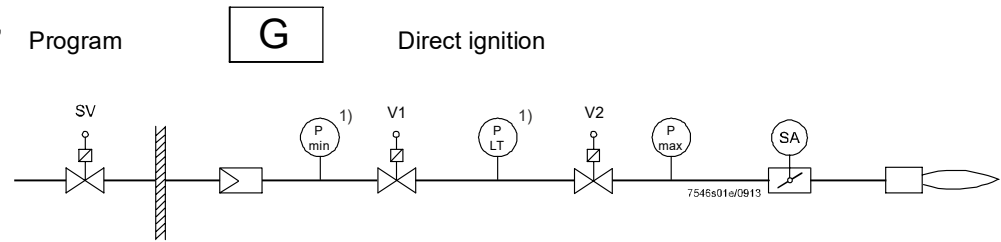

Figure 42: Gas direct ignition

Gas pilot ignition 1
(Operating mode 2, 8, 15, 20)

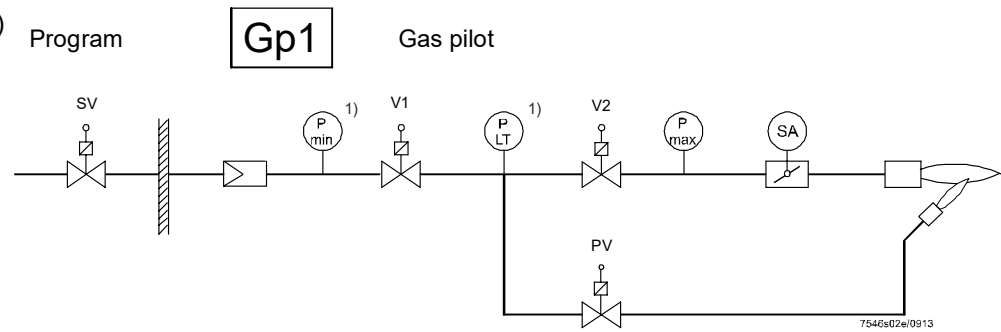

Figure 43: Gas pilot ignition 1

Gas pilot ignition 2
(Operating mode 3, 9, 16, 21, 29)

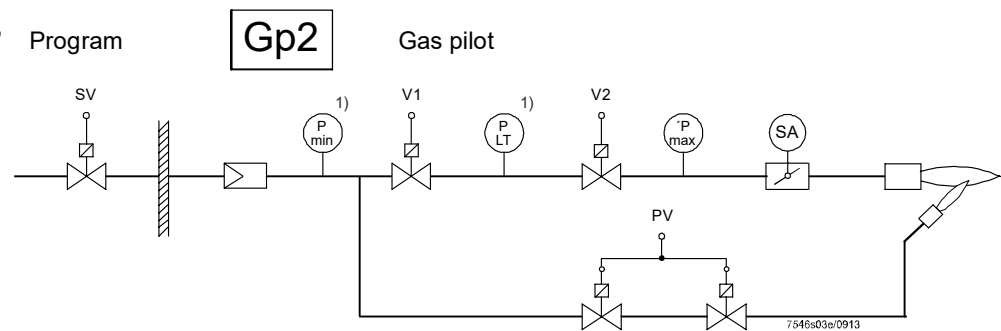

Figure 44: Gas pilot ignition 2

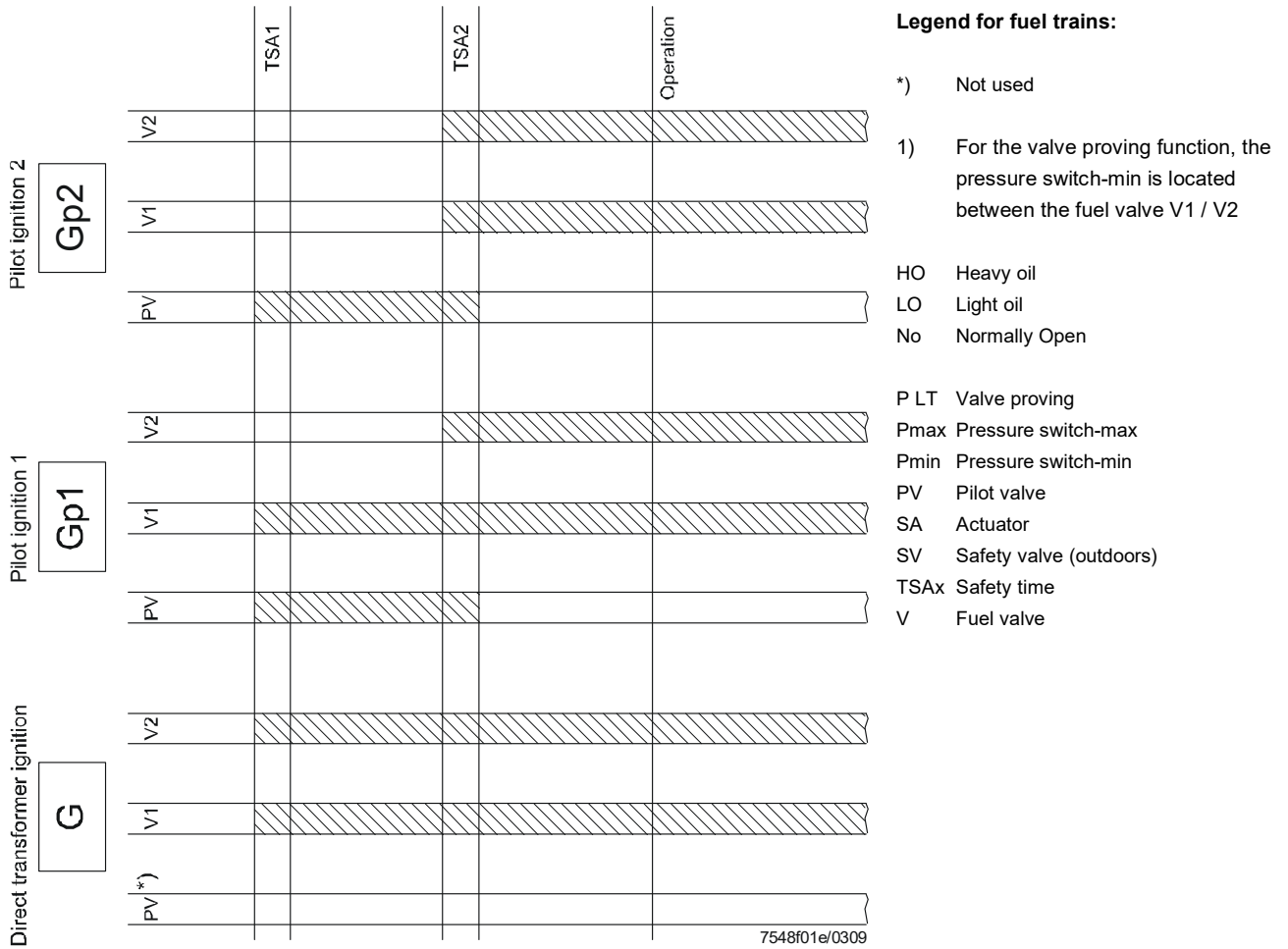

Figure 45: Gas – fuel valve control

Light oil direct ignition,
multistage
(Operating mode 5, 17)

1-stage burner

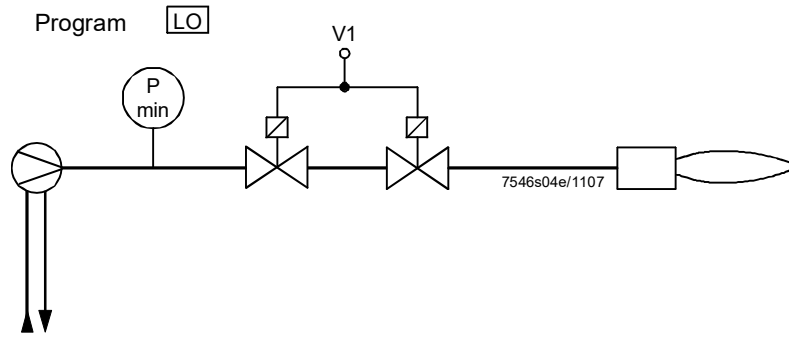

Figure 46: Light oil direct ignition, 1-stage

(Operating mode 5, 17)

2-stage burner

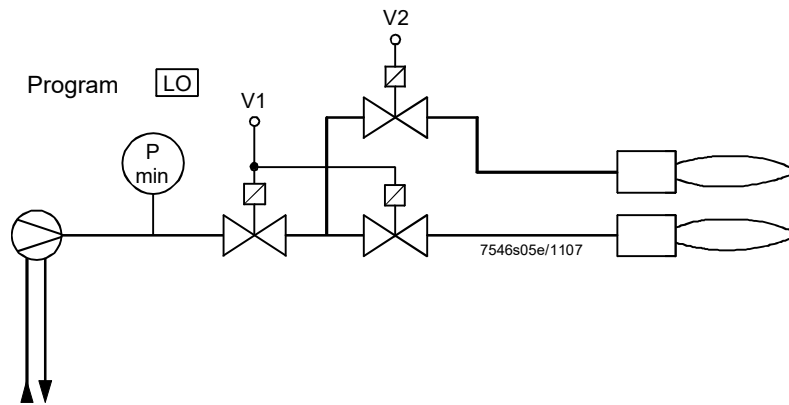

Figure 47: Light oil direct ignition, 2-stage

(Operating mode 6, 18)

3-stage burner

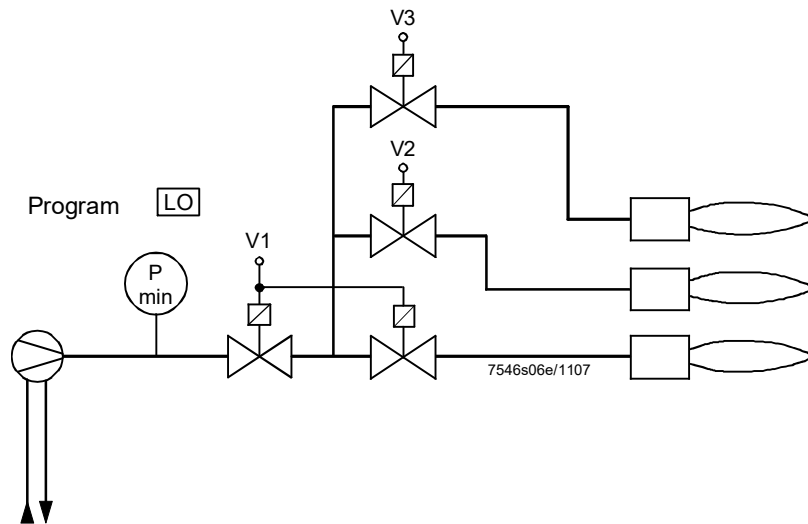

Figure 48: Light oil direct ignition, 3-stage

Light oil direct ignition,
modulating
(Operating mode 4, 22)

Modulating burner (without shutdown facility for adjustable head)

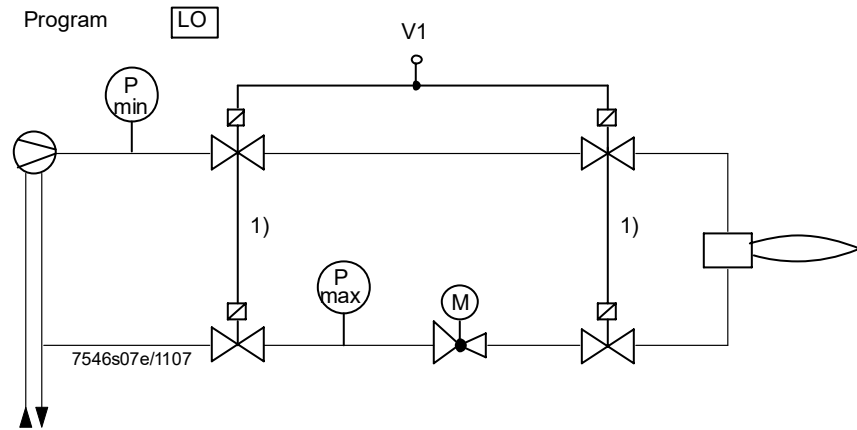

Figure 49: Light oil direct ignition, modulating

(Operating mode 4, 22)

Modulating burner (with shutdown facility for adjustable head)

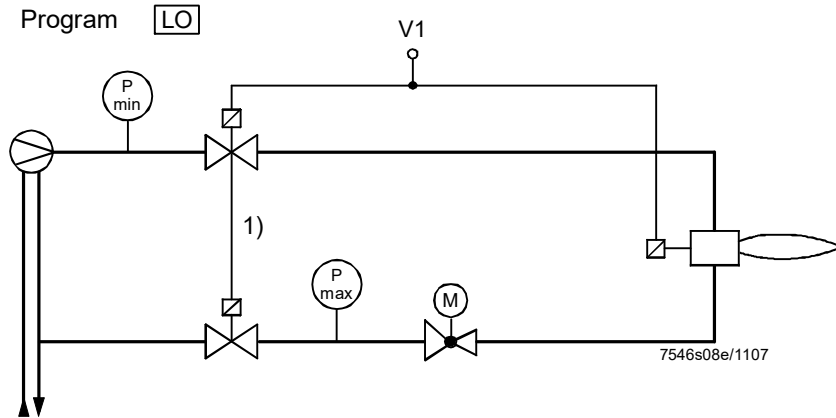

Figure 50: Light oil ignition, modulating

Fuel valve control

Light oil (transformer for direct ignition) and heavy oil without separate circulation control

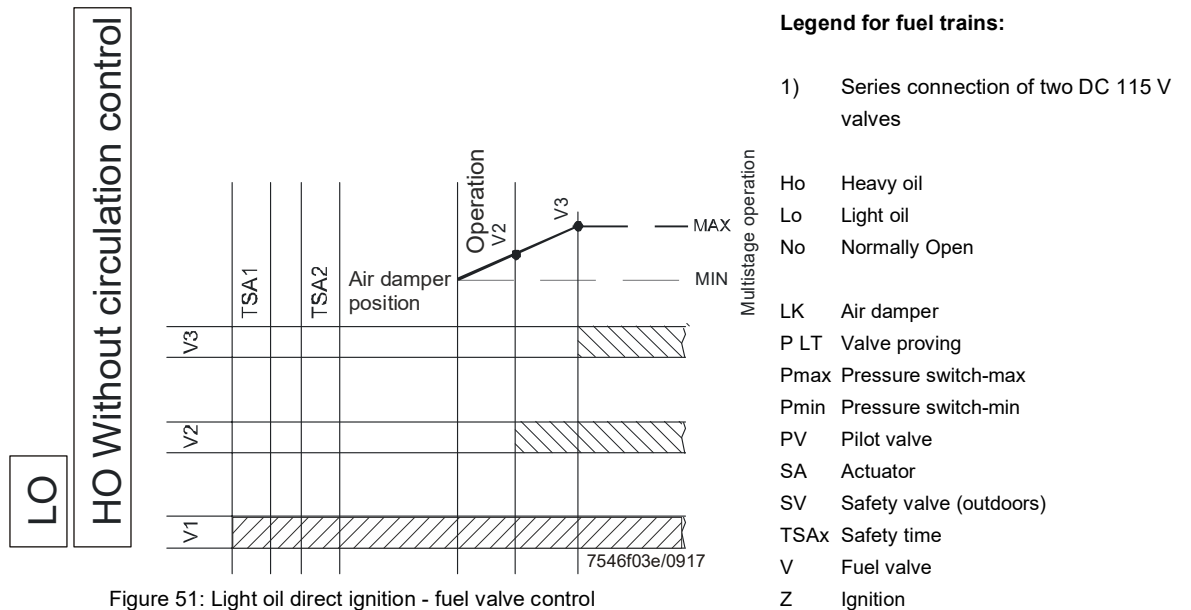

Figure 51: Light oil direct ignition - fuel valve control

Light oil direct ignition
modulating with 2 fuel valves
(Operating mode 12)

Modulating burner (without shutdown facility for adjustable head)

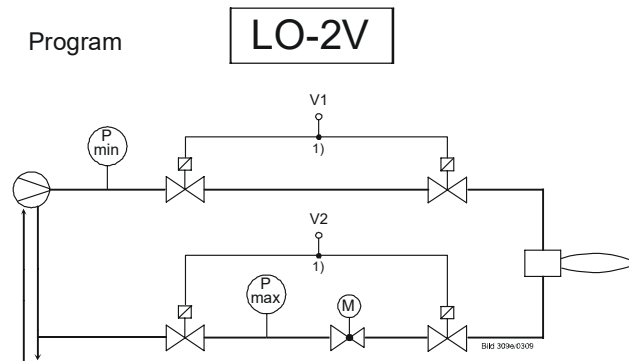

Figure 52: Light oil direct ignition, modulating, without shutdown facility for adjustable head

(Operating mode 12)

Modulating burner (with shutdown facility for adjustable head)

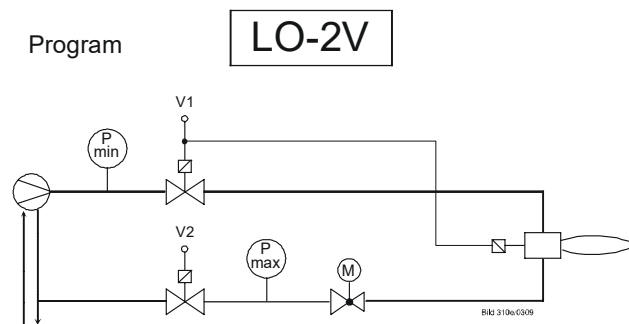

Figure 53: Light oil direct ignition, modulating, with shutdown facility for adjustable head

Fuel valve control

Light oil (transformer for direct ignition)

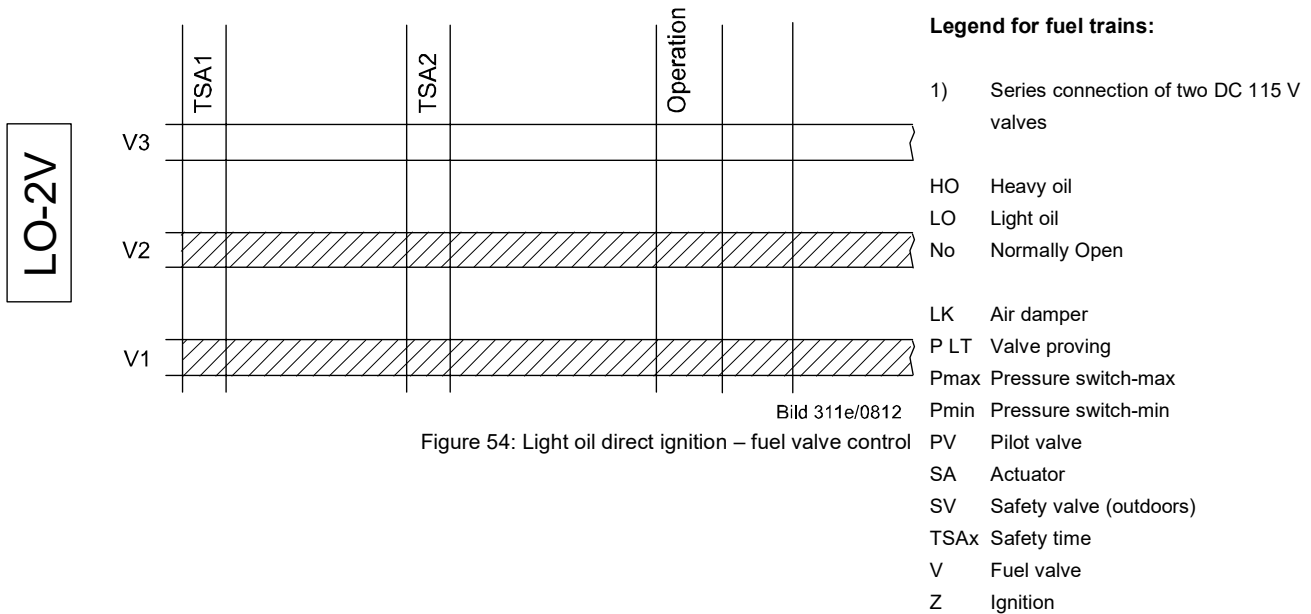

Figure 54: Light oil direct ignition – fuel valve control

Light oil with gas pilot ignition

(Operating mode 3, 9, 16, 21)

Program

LOGp

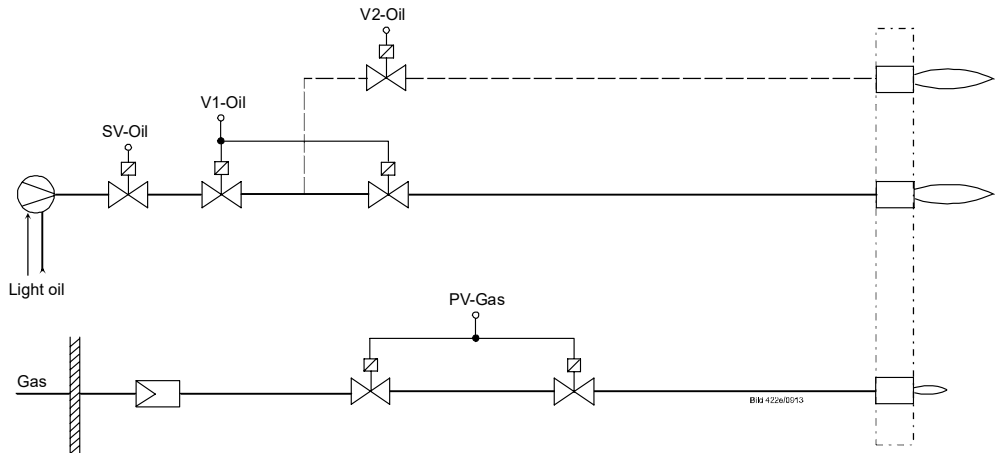

(Operating mode 10, 11)

Figure 55: Light oil with gas pilot ignition

Fuel valve control

Light oil (with gas pilot ignition)

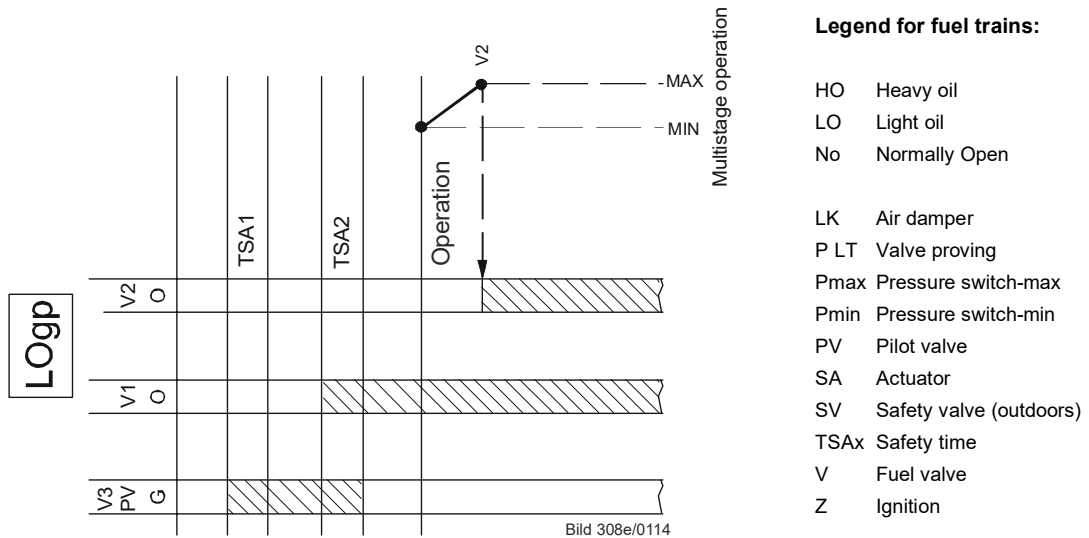

Figure 56: Light oil with gas pilot ignition – fuel valve control

Light oil with gas pilot ignition
with 2 fuel valves

(Operating mode 3, 9, 16, 21)

Program

LOgp-2V

(Operating mode 13)

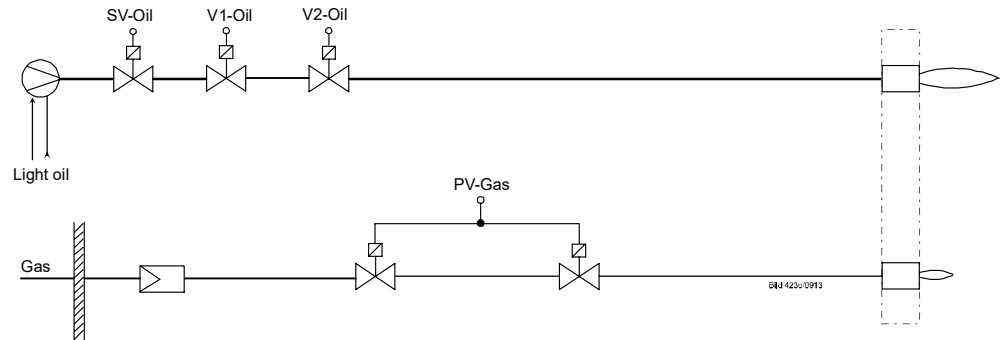

Figure 57: Light oil with gas pilot ignition

Fuel valve control

Light oil (with gas pilot ignition)

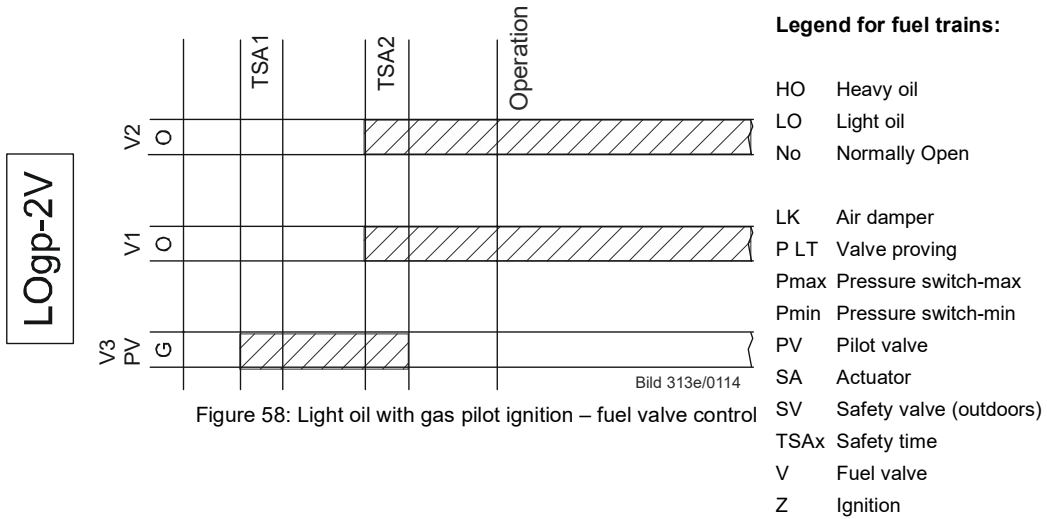

Figure 58: Light oil with gas pilot ignition – fuel valve control

Heavy oil direct ignition,
multistage

(Operating mode 24)

2-stage burner

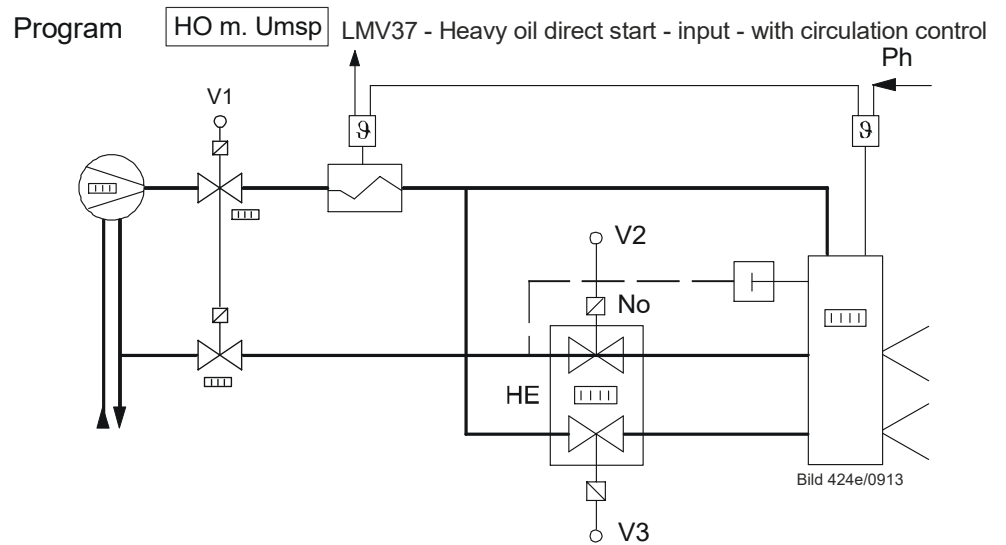

Figure 59: Heavy oil direct ignition, 2-stage, with circulation control

Heavy oil direct ignition,
modulating

(Operating mode 23)

Modulating burner

Circulation control from phase 38, maximum 45 seconds as soon as direct heavy oil start = ON in phase 38:

→ Phase change in phase 40

Direct heavy oil start = OFF at the end of phase 38:

→ Restart (a maximum of 3 times)

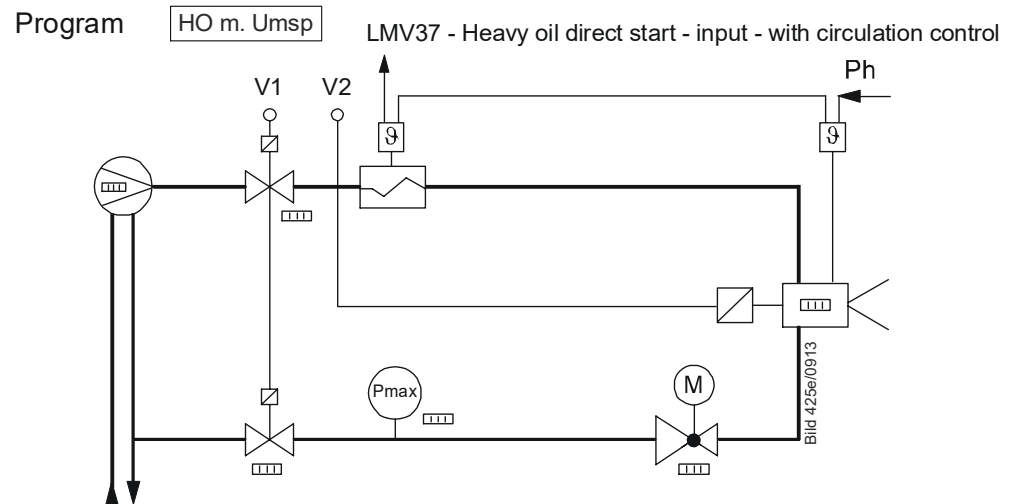

Figure 60: Heavy oil direct ignition, modulating, with circulation control

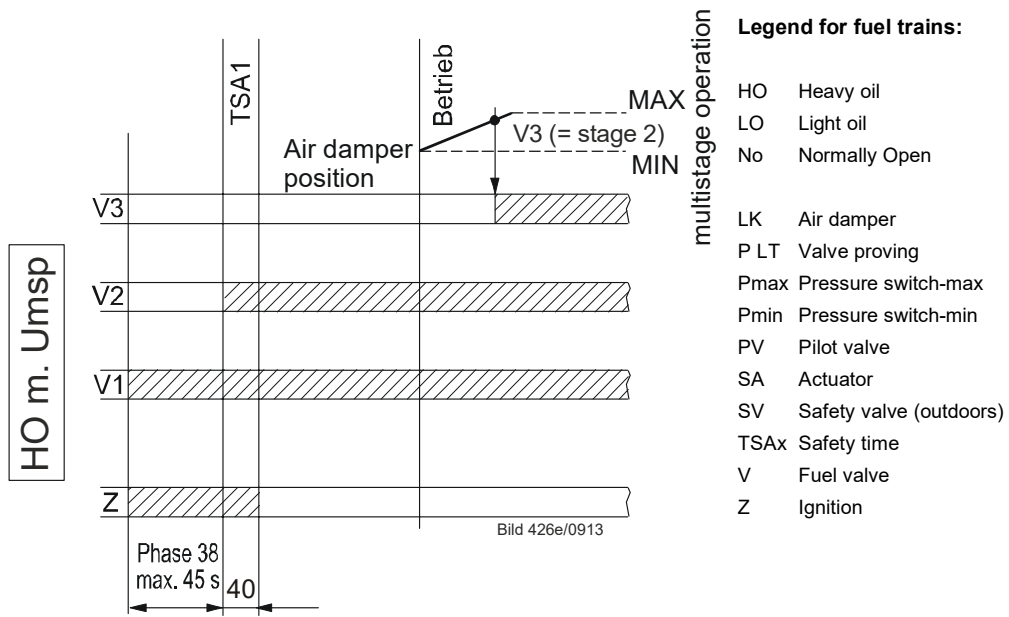

Figure 61: Heavy oil direct ignition – fuel valve control

7.7 Sequence diagrams

The phase numbers given in the sequence diagrams can be read from the following process data:

No.	Parameter
961	Phase (state of external module and display)

7.7.1 Gas direct ignition «G», «G mod», «G mod pneu»



Bild 06e/0913

Figure 62: Program for gas direct ignition «G», «G mod», «G mod pneu»

7.7.2 Gas pilot ignition 1 «Gp1», «Gp1 mod», «Gp1 mod pneu»

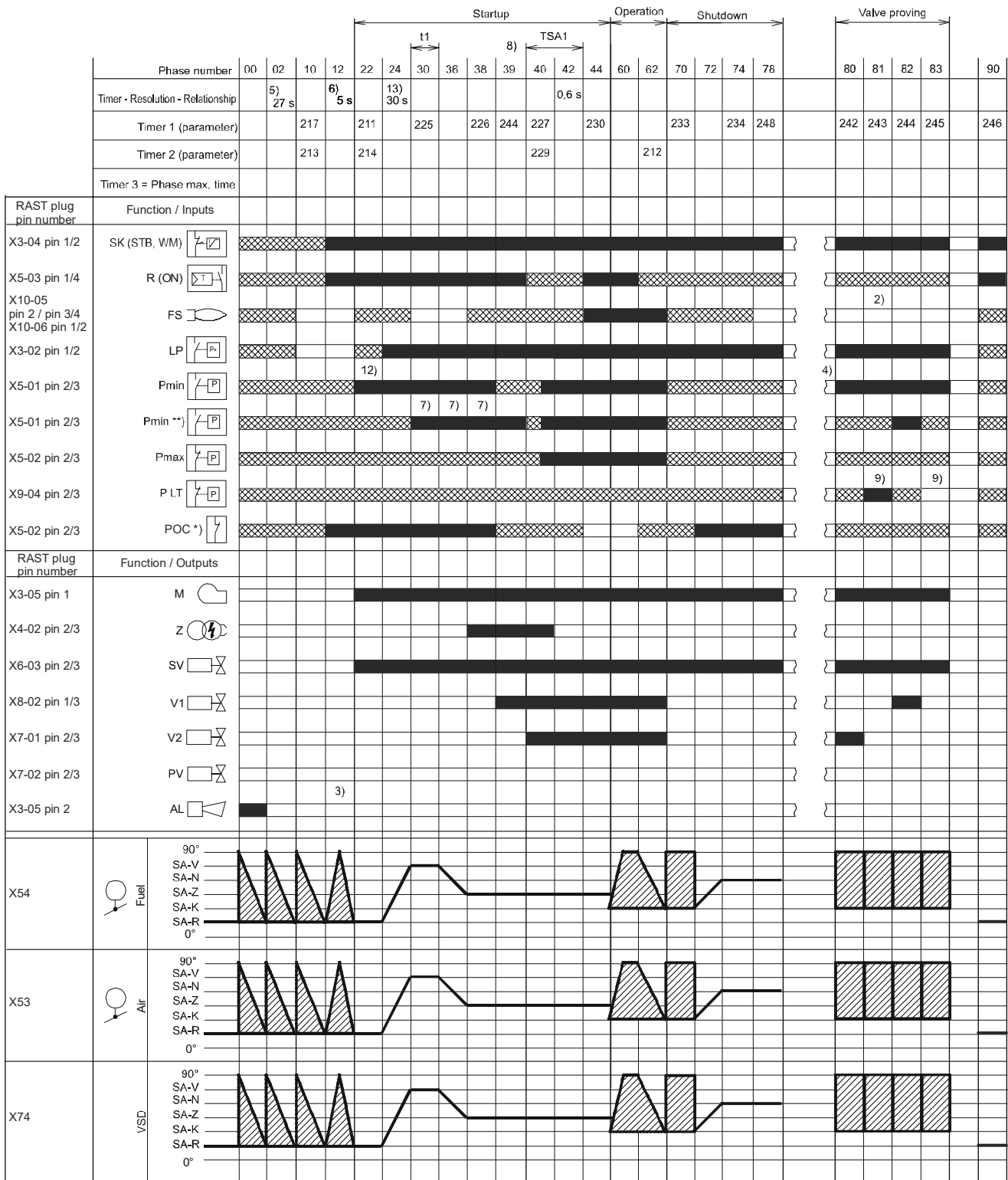
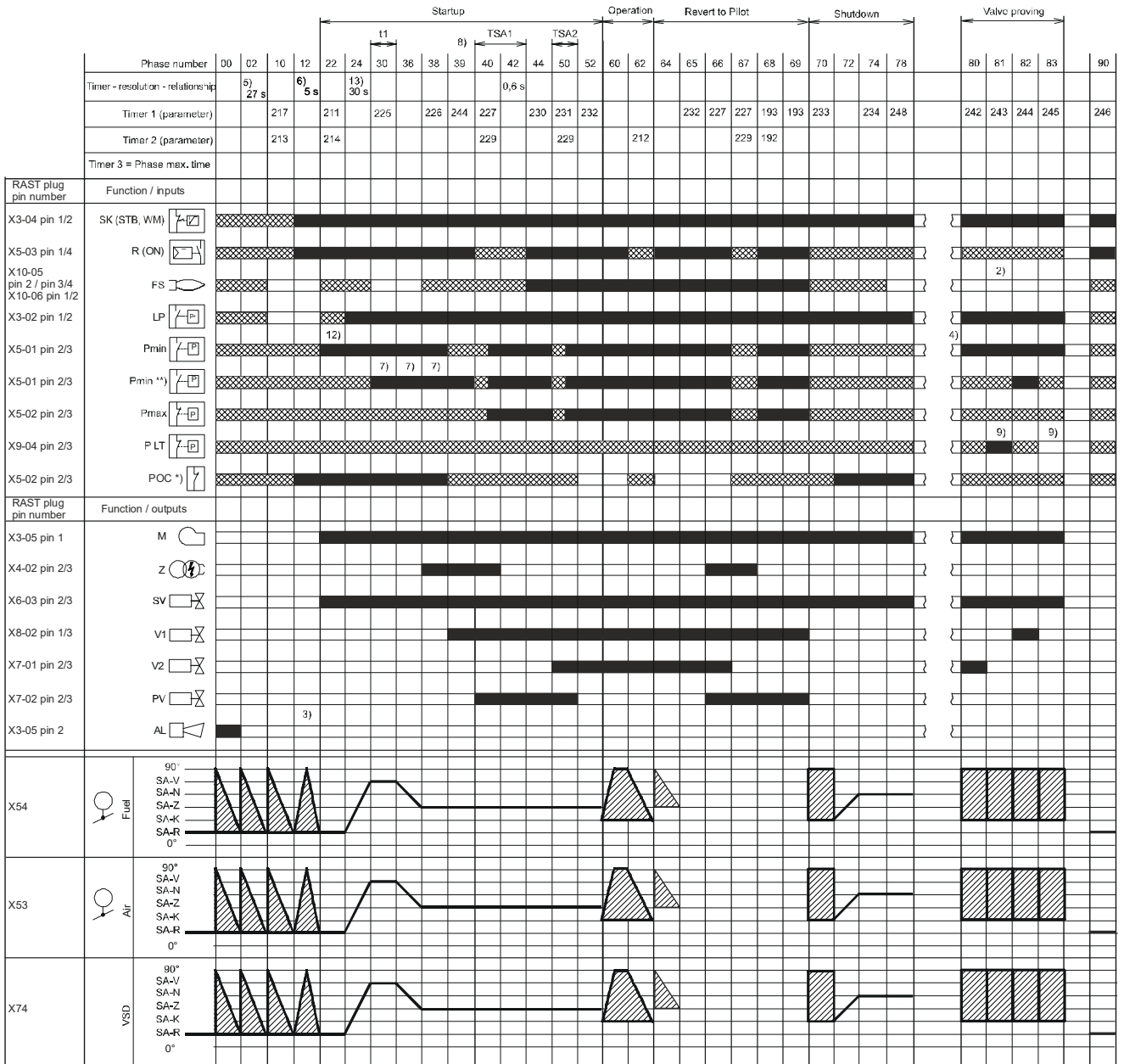
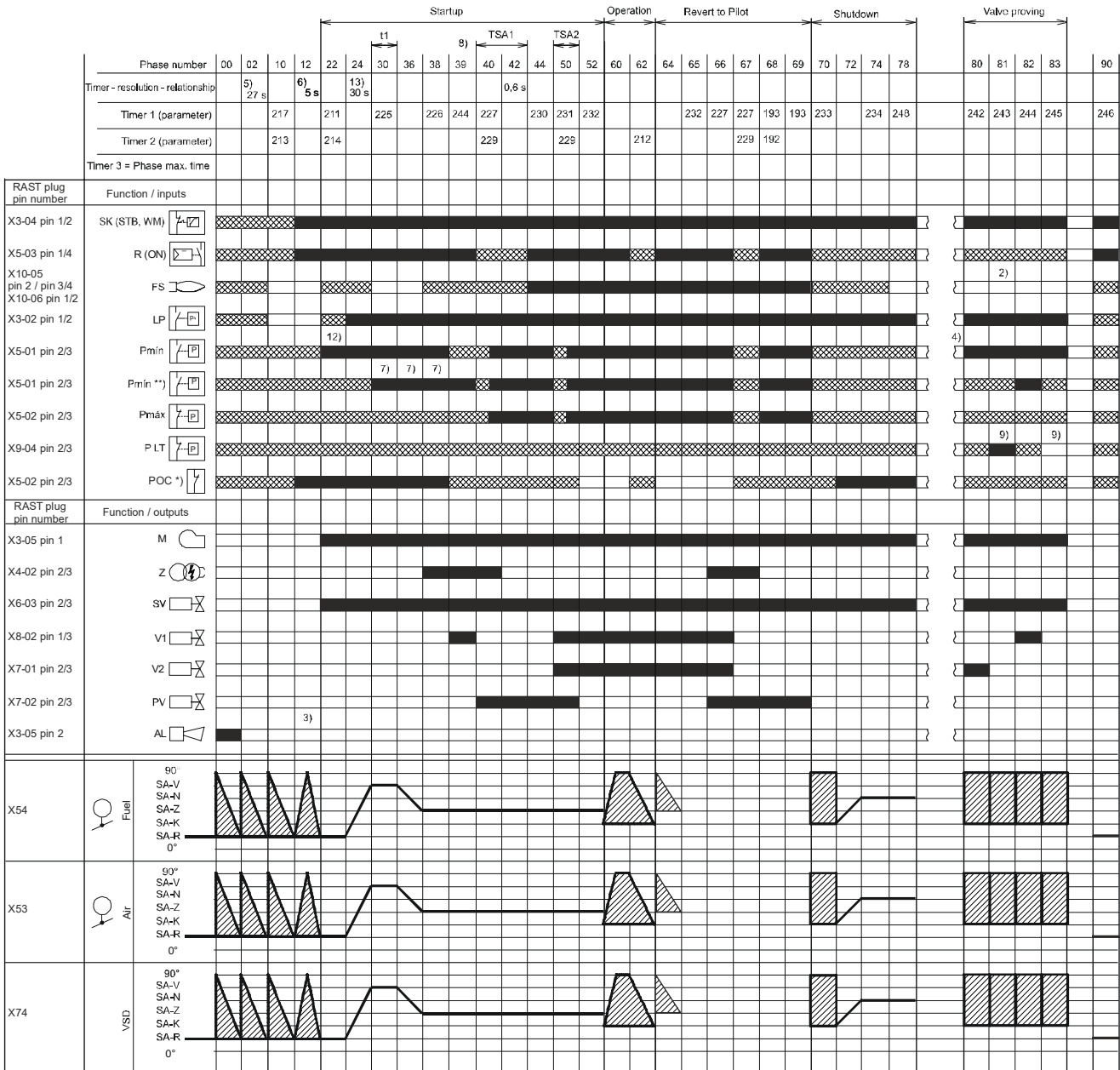

Figure 63: Program for gas pilot ignition «Gp1», «Gp1 mod», «Gp1 mod pneu»

Bild 18a/0913

7.7.3 Gas pilot ignition 2 «Gp2», «Gp2 mod», «Gp2 mod pneu»



Bit 19e/0913

Figure 64: Program for gas pilot ignition «Gp2», «Gp2 mod», «Gp2 mod pneu»

7.7.4 Light oil direct ignition «Lo», «Lo mod», «Lo 2-stage», «Lo 3-stage»



Bild 03e/1010

Figure 65: Program for light oil direct ignition «Lo», «Lo mod», «Lo 2-stage», «Lo 3-stage»

7.7.5 Light oil pilot ignition «LoGp» «LoGp mod» «LoGp 2 stage»

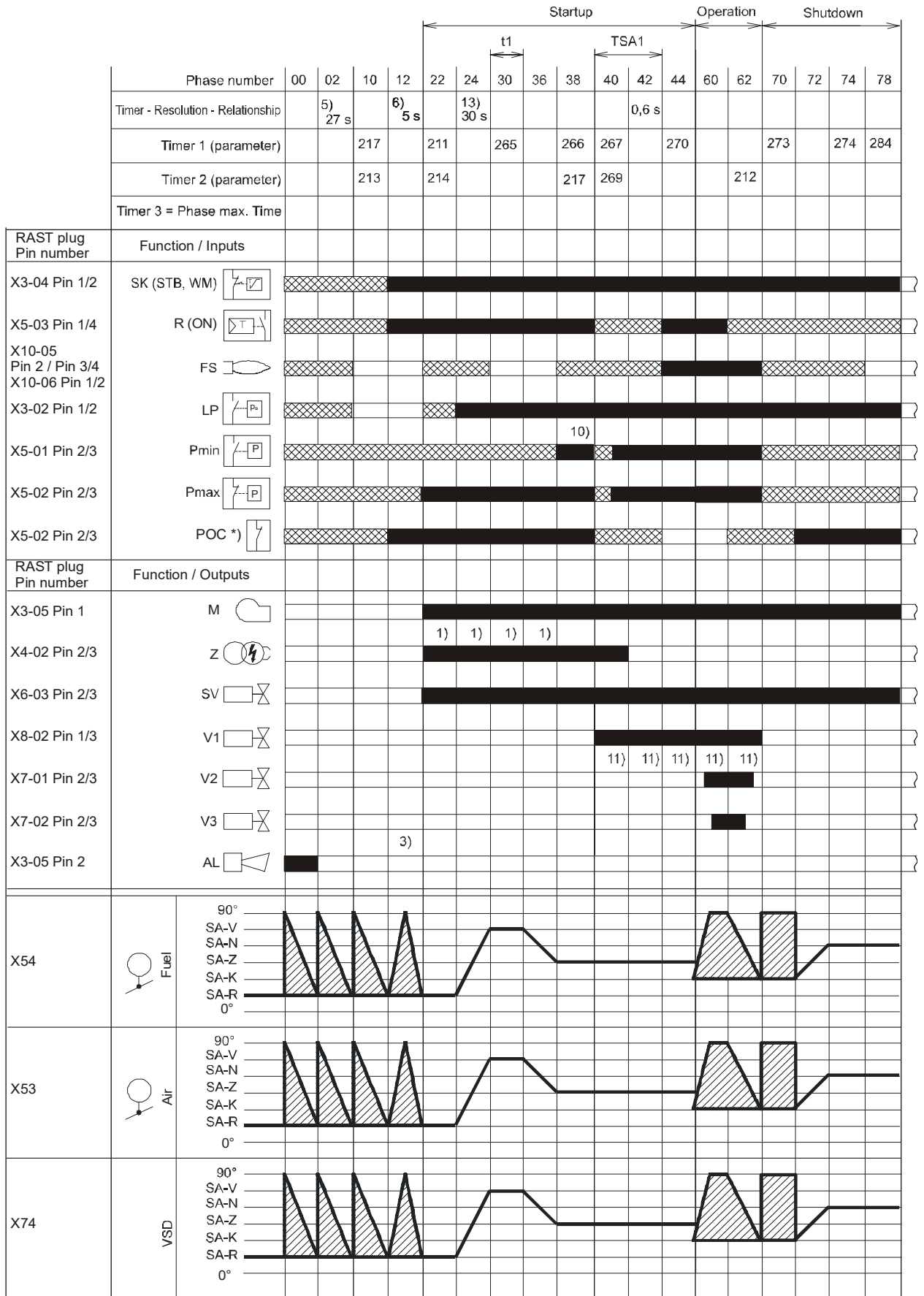

Bild 01e/0913

Figure 66: Program light oil pilot ignition «LoGp» «LoGp mod» «LoGp 2 stage»

7.7.6 Heavy oil direct ignition «Ho», «Ho mod separate circulation control», «Ho 2-stage separate circulation control»

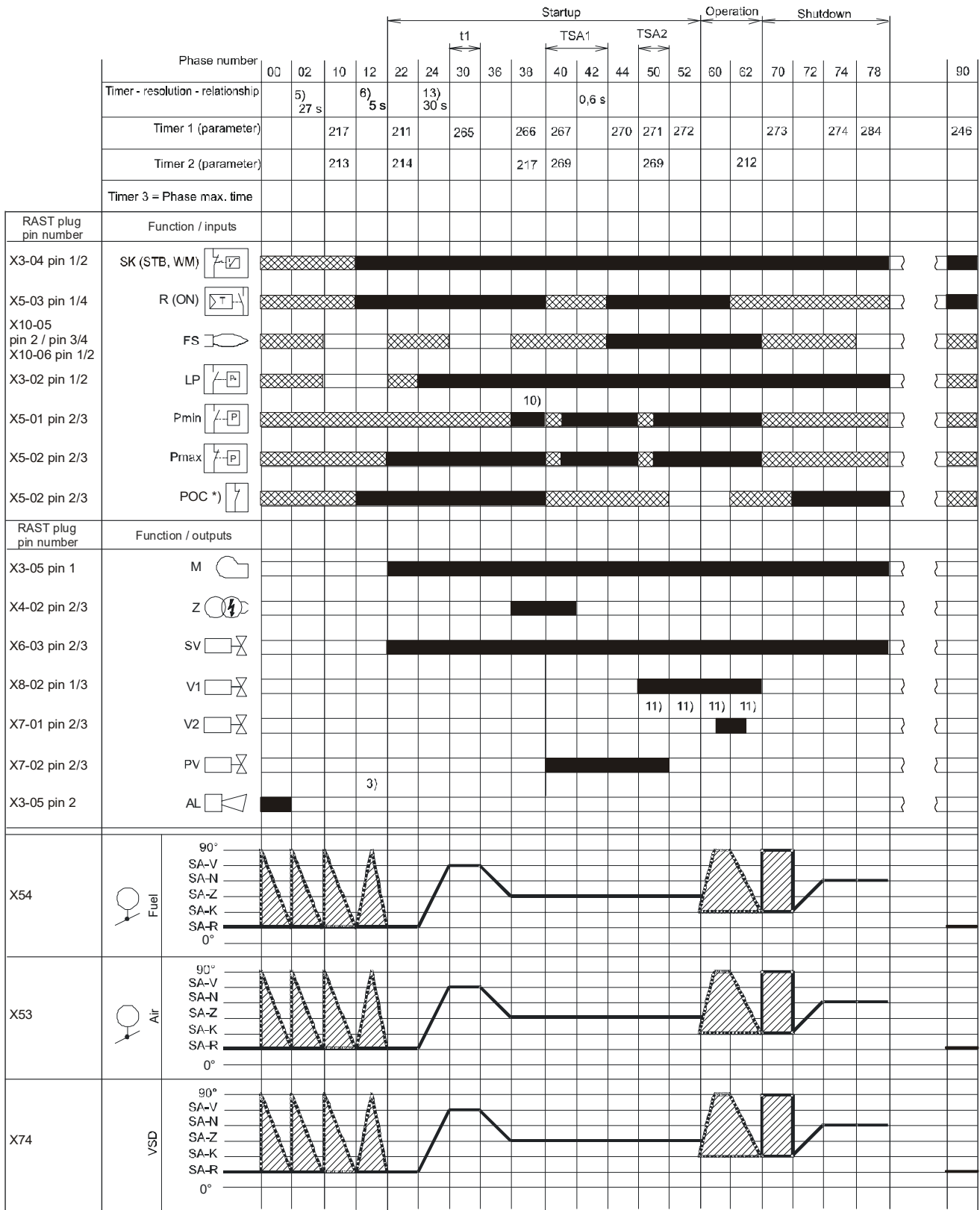

Bild 16e/0913

Figure 67: Program Heavy oil direct ignition «Ho», «Ho mod separate circulation control», «Ho 2-stage separate circulation control»

7.7.7 Heavy oil direct ignition «Ho», «Ho mod without circulation control», «Ho 2-stage without circulation control», «Ho 3-stage without circulation control»

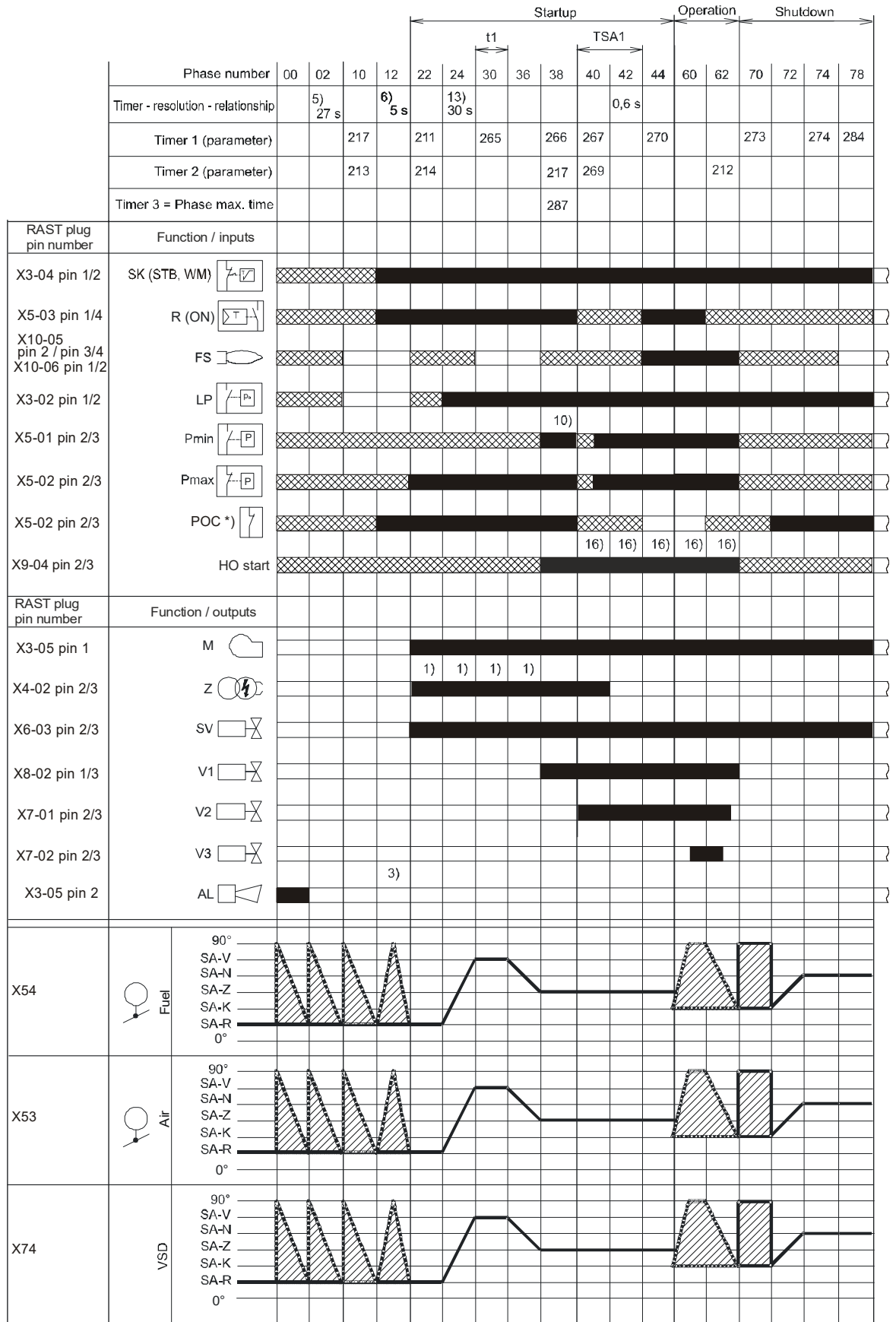

Bild 17e/0913

Figure 68: Program heavy oil direct ignition «Ho», «Ho mod without circulation control», «Ho 2-stage without circulation control», «Ho 3-stage without circulation control»

7.7.8 Legend to the sequence diagrams

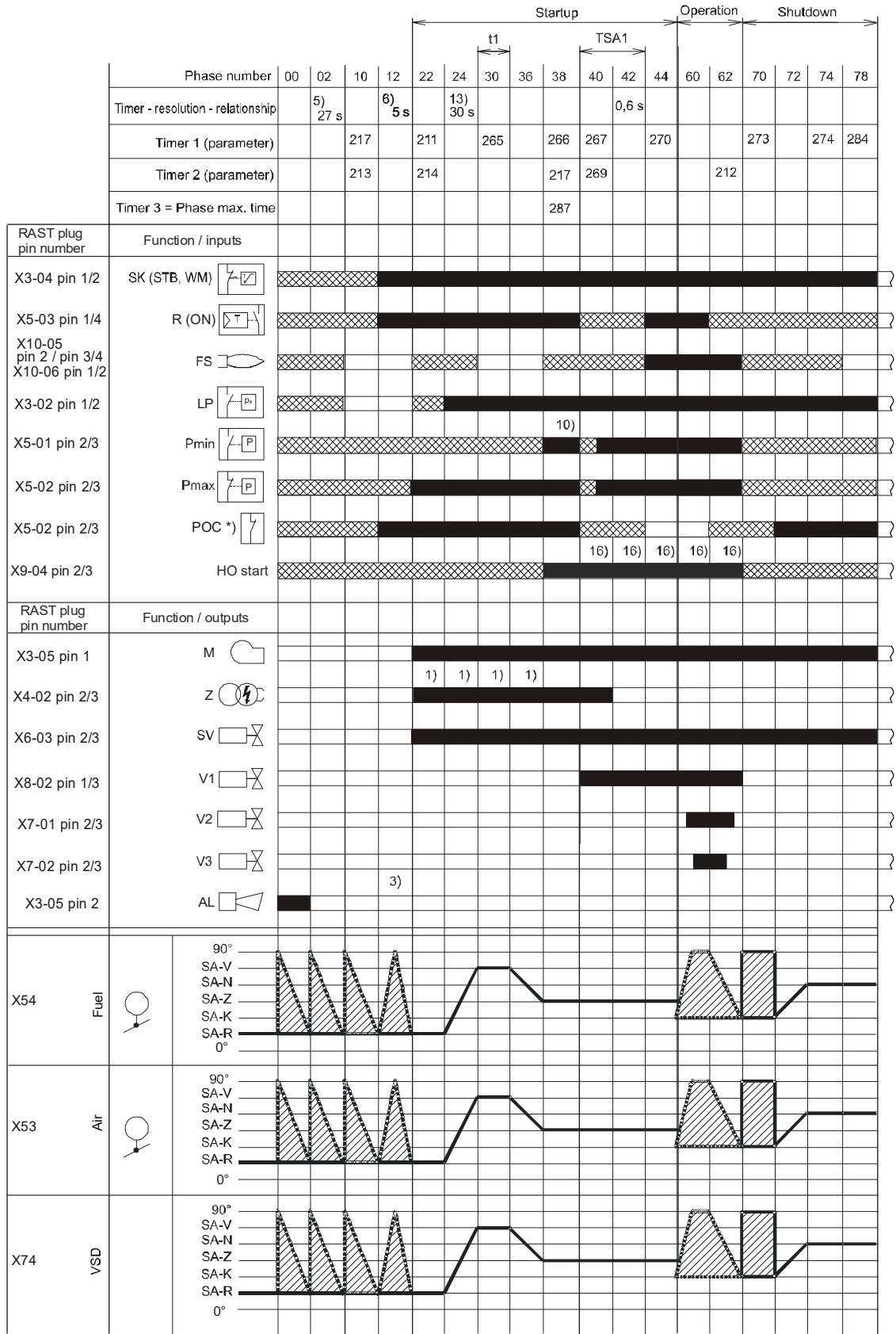

Note

Not all phases, times, indices, abbreviations and symbols appear in the individual sequence diagrams or are needed there!

Phase numbers

00	Lockout phase
02	Safety phase
10	Home run
12	Standby (stationary)
22	Fan motor = ON, safety valve = ON
24	Air damper ⇒ pre purge position
30	Prepurging
35	Fan ⇒ ignition speed
36	Air damper ⇒ ignition position
38	Preignition ignition = ON
39	Test pressure switch-min
40	Fuel valve = ON
42	Ignition = OFF
44	Interval 1
50	Second safety time
52	Interval 2
60	Operation 1 (stationary)
62	Operation 2 (air damper ⇒ low-fire position)
64	Switching back to pilot: Modulation to ignition load
65	Switching back to pilot: Interval 2 waiting time
66	Switching back to pilot: Reactivation of ignition + pilot
67	Switching back to pilot: Shutdown of main valves
68	Switching back to pilot: Pilot mode waiting phase
69	Switching back to pilot: Pilot mode waiting phase for burner startup
70	Afterburn time
71	Fan ⇒ postpurge speed
72	Air damper ⇒ Rated load position
74	Postpurge time
78	Postpurge time
79	Fan ⇒ standby speed
80	Evacuation of test space
81	Test time atmospheric pressure
82	Filling of test space
83	Test time gas pressure
90	Gas shortage waiting time

Valve proving is performed depending on the parameter settings:
Simultaneously with the prepurge time **and/or** the afterburn time.

Times

TSA1	1st safety time
TSA2	2nd safety time
t1	Prepurge time
t3	Postpurge time
t8	Postpurge time
t13	Afterburn time
t44	Interval 1
t52	Interval 2

Indices

1)	Parameter:	Short/long prepurge time for oil only Short/long oil pump – ON – time
2)	Only with valve proving during startup	
3)	Parameter:	With/without alarm in the event of start prevention
4)	If signal is faulty in the startup phase, phase 10 is next, otherwise phase 70	
5)	Maximum time safety phase, then lockout	
6)	Time from occurrence of start prevention to signaling	
7)	Only in case of valve proving during startup (valve proving via pressure switch-min)	
8)	Only in case of startup without valve proving (valve proving via pressure switch-min)	
9)	Inverse logic in case of valve proving via pressure switch-min	
10)	Parameter 276:	Oil: Input oil pressure min 1 = active from phase 38 2 = active from safety time
11)	Only with fuel train <i>Lo</i> and 2 fuel valves	
12)	Parameter 223:	Restart limit value: Gas pressure switch-min in conjunction with the gas shortage program (parameter 246 / phase 90) 1 = no restart 2...15 = 1...14 restarts 16 = continuous restart
13)	Maximum drop-in/response time for air pressure switch	
14)	Alternative to valve proving	
15)	Alternative to pressure switch-max or POC	
16)	Parameter 286:	Oil: Evaluation of heavy oil direct start 0 = only start signal in phase 38 1 = evaluation in phase 38...62

Abbreviations

AL	Alarm
FS	Flame signal
GM	Fan motor contactor
LP	Air pressure switch
M	Fan motor
P LT	Pressure switch for valve proving
Pmax	Pressure switch-max
Pmin	Pressure switch-min
POC	Proof of closure
PV	Pilot valve
R	Temperature or pressure controller
SB	Safety limiter
SK	Safety loop
STB	Safety limit thermostat
SV	Safety valve
WM	Water shortage
V1	Fuel valve V1
V2	Fuel valve V2
VP	Combustion pressure switch
Z	Ignition transformer
SA	Actuator
SA-K	Low-fire position of actuator
SA-N	Postpurge position of actuator
SA-R	Home position of actuator
SA-V	Rated load position of actuator
SA-Z	Ignition load position of actuator

Symbols



Permissible position range



In *Standby* mode: Actuator is allowed to travel within the permissible position range, but is always driven to the home position; must be in the home position for phase changes

0°/10%
90°/100%

Position as supplied (0°)
Actuator fully open (90°)



Input/output signal 1 (ON)
Input/output signal 0 (OFF)
Input permissible signal 1 (ON) or 0 (OFF)

*)
**)

Alternative to pressure switch-max
Only with valve proving via pressure switch-min

8 Selection of operating mode

To facilitate straightforward adaptation of the LMV37.4 to different types of burners, the LMV37.4 offers automatic configuration of the operating mode. This means that – derived from parameter 201 – the most important settings relating to the operating mode are made automatically. Very often in that case, the only manual settings to be made are those for the fuel-air ratio control system. After selection of the operating mode, parameters that are not required will be hidden (e.g. oil parameters when firing on gas).

No.	Parameter
201	Burner operating mode (fuel train, modulating / multistage, actuators, etc.) -- = undefined (delete curves) 1 = G mod 2 = Gp1 mod 3 = Gp2 mod 4 = Lo mod 5 = Lo 2-stage 6 = Lo 3-stage 7 = G mod pneu 8 = Gp1 mod pneu 9 = Gp2 mod pneu 10 = LoGp mod 11 = LoGp 2-stage 12 = Lo mod 2 fuel valves 13 = LoGp mod 2 fuel valves 14 = G mod pneu without actuator 15 = Gp1 mod pneu without actuator 16 = Gp2 mod pneu without actuator 17 = Lo 2-stage without actuator 18 = Lo 3-stage without actuator 19 = G mod gas actuator only 20 = Gp1 mod gas actuator only 21 = Gp2 mod gas actuator only 22 = Lo mod oil actuator only 23 = Ho mod separate circulation control 24 = Ho 2-stage separate circulation control 25 = Ho mod without circulation control 26 = Ho 2-stage without circulation control 27 = Ho 3-stage without circulation control 28 = G mod mech air actuator only 29 = Gp2 mod mech air actuator only

Operating mode parameter 201	Fuel train	Fuel-air ratio control	Fuel actuator	Air actuator	Feedback signal VSD	Description
1	G mod	Modulating electronic	•	•	•	Gas direct ignition, electronic modulating ratio control. Optional with VSD with speed feedback signal
2	Gp1 mod	Modulating electronic	•	•	•	Gas pilot ignition 1, electronic modulating ratio control. Optional with VSD with speed feedback signal
3	Gp2 mod	Modulating electronic	•	•	•	Gas pilot ignition 2, electronic modulating ratio control. Optional with VSD with speed feedback signal
4	Lo mod	Modulating electronic	•	•	•	Oil direct ignition, electronic modulating ratio control. Optional with VSD with speed feedback signal

Operating mode parameter 201	Fuel train	Fuel-air ratio control	Fuel actuator	Air actuator	Feedback signal VSD	Description
5	Lo 2-stage	2-stage		•	•	Oil direct ignition, electronic 2-stage ratio control. Optional with VSD with speed feedback signal
6	Lo 3-stage	3-stage		•	•	Oil direct ignition, electronic 3-stage ratio control. Optional with VSD with speed feedback signal
7	G mod pneu	Modulating pneumatic		•		Gas direct ignition, pneumatic modulating ratio control. Optional with VSD.
8	Gp1 mod pneu	Modulating pneumatic		•		Gas pilot ignition 1, pneumatic modulating ratio control. Optional with VSD.
9	Gp2 mod pneu	Modulating pneumatic		•		Gas pilot ignition 2, pneumatic modulating ratio control. Optional with VSD.
10	LoGp mod	Modulating electronic	•	•	•	Oil pilot ignition, electronic modulating ratio control. Optional with VSD with speed feedback signal
11	LoGp 2-stage	2-stage		•	•	Oil pilot ignition, electronic 2-stage ratio control. Optional with VSD with speed feedback signal
12	Lo mod 2 fuel valves	Modulating electronic	•	•	•	Oil direct ignition, 2 fuel valves, electronic modulating ratio control. Optional with VSD with speed feedback signal
13	LoGp mod 2 fuel valves	Modulating electronic	•	•	•	Oil pilot ignition, 2 fuel valves, electronic modulating ratio control. Optional with VSD with speed feedback signal
14	G mod pneu without actuator	Modulating pneumatic				Gas direct ignition, without actuator, pneumatic modulating ratio control. Optional with VSD.
15	Gp1 mod pneu without actuator	Modulating pneumatic				Gas pilot ignition 1, without actuator, pneumatic modulating ratio control. Optional with VSD.
16	Gp2 mod pneu without actuator	Modulating pneumatic				Gas pilot ignition 2, without actuator, pneumatic modulating ratio control. Optional with VSD.
17	Lo 2-stage without actuator	2-stage			•	Oil direct ignition, without actuator, electronic 2-stage ratio control. Optional with VSD with speed feedback signal
18	Lo 3-stage without actuator	3-stage			•	Oil direct ignition, without actuator, electronic 3-stage ratio control. Optional with VSD with speed feedback signal
19	G mod only gas actuator	Modulating electronic	•		•	Gas direct ignition, only gas actuator. modulating ratio control. Optional with VSD with speed feedback signal
20	Gp1 mod only gas actuator	Modulating electronic	•		•	Gas pilot ignition 1, only gas actuator. modulating ratio control. Optional with VSD with speed feedback signal
21	Gp2 mod only gas actuator	Modulating electronic	•		•	Gas pilot ignition 2, only gas actuator. modulating ratio control. Optional with VSD with speed feedback signal
22	Lo mod only oil actuator	Modulating electronic	•		•	Oil direct ignition, only oil actuator. modulating ratio control. Optional with VSD with speed feedback signal
23	Ho mod separate circulation control	Modulating electronic	•	•	•	Heavy oil direct ignition, with circulation control, electronic modulating ratio control. Optional with VSD with speed feedback signal

Operating mode parameter 201	Fuel train	Fuel-air ratio control	Fuel actuator	Air actuator	Feedback signal VSD	Description
24	Ho 2 stage separate circulation control	2-stage		•	•	Heavy oil direct ignition, with circulation control, electronic 2-stage ratio control. Optional with VSD with speed feedback signal
25	Ho mod without circulation control	Modulating electronic	•	•	•	Heavy oil direct ignition, without circulation control, electronic modulating ratio control. Optional with VSD with speed feedback signal
26	Ho 2 stage without circulation control	2-stage		•	•	Heavy oil direct ignition, without circulation control, electronic 2-stage ratio control. Optional with VSD with speed feedback signal
27	Ho 3 stage without circulation control	3-stage		•	•	Heavy oil direct ignition, without circulation control, electronic 3-stage ratio control. Optional with VSD with speed feedback signal
28	G mod mech only air actuator	Modulating mechanical		•	•	Gas direct ignition, only air actuator, mechanical modulating ratio control. Optional with VSD with speed feedback signal
29	Gp2 mod mech only air actuator	Modulating mechanical		•	•	Gas pilot ignition 2, only air actuator, mechanical modulating ratio control. Optional with VSD with speed feedback signal

(Also refer to chapter *Fuel trains*)

The VSD can be used with any of the operating modes (refer to chapter *VSD*).

No.	Parameter
542	Activation of VSD / PWM fan 0 = deactivated 1 = active 2 = activated (No restart)



Note

For configuration of the analog output when the VSD is activated, refer to chapter *Load output X74 pin 3!*

8.1 Deleting curves

To delete curves, the operating mode must be set to undefined «--». In that case, only the fuel curves are deleted, the direction of rotation or the reference position of the actuators is not changed.

9 Connection to load controllers

The LMV37.4 can be connected to different load controllers. Heat request and the required burner output are determined in accordance with the priorities of the different load sources.

9.1 Load controller ON contact X5-03 pin 1

This contact is given priority over all load controller sources. A heat request can only be made when this contact is closed. The contact is safety-related and can also be used in connection with load controllers featuring an integrated temperature limiter function.

9.2 External load controller via contacts X5-03, pin 2 / pin 3

The heat request is delivered via pin 1. Modulation of burner output is effected via pin 2 and 3. Here, a differentiation is made between modulating and multistage operation (refer to chapter *Selection of operating mode*).

Modulating operation X5-03 (OPEN pin 3 / CLOSE pin 2)

If input *Open* is active, the burner's output is increased. If input *Close* is active, the burner's output is decreased. If none of the inputs is active, the burner's output is not changed. The rate of integration is 32 seconds for changing the output from low-fire to high-fire (parameter 544), that is from 20 % to 100 %, or vice versa. Output integration always takes place in the operating position. 200 ms is the shortest positioning step that is securely detected.

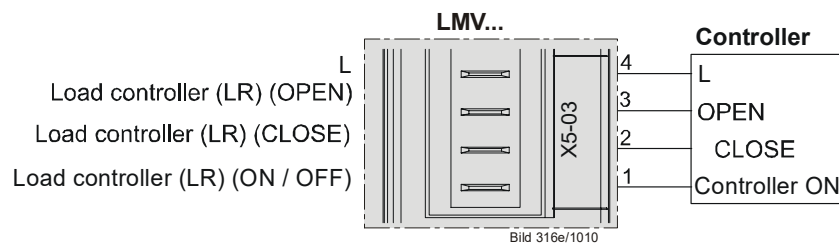

Figure 69: Modulating operation X5-03



Note!

When the *Switching back to pilot* function is used, the load controller inputs OPEN CLOSE (X5-03 pin 2 and 3) are not available (refer to chapter *Switching back to pilot*). Analog input X64 is used as the load controller source in this case.

No.	Parameter
544	Ramp modulating

Minimum positioning step

To prevent the actuators from making unnecessary position changes when the preselected target output varies, a minimum positioning step can be set. In that case, the LMV37.4 changes the output only when the preselected target output exceeds the minimum positioning step. This minimum positioning step is only used in modulating operation.

No.	Parameter
123.2	Minimum output positioning step: Output of external load controller contacts

Multistage operation X5-03 (stage 2, pin 3 / stage 3, pin 2)

In multistage operation, 1 or 2 thermostats can be connected to activate the different burner stages. Multistage operation is possible only when firing on oil.

If neither input «Stage 2» nor input «Stage 3» is active, the burner switches to «Stage 1».

If input «Stage 2» becomes active, the burner switches to the second stage.

If input «Stage 3» becomes active, the burner switches to the third stage. In that case, input «Stage 2» can be active or inactive. The third stage can only be activated with 3-stage operation.

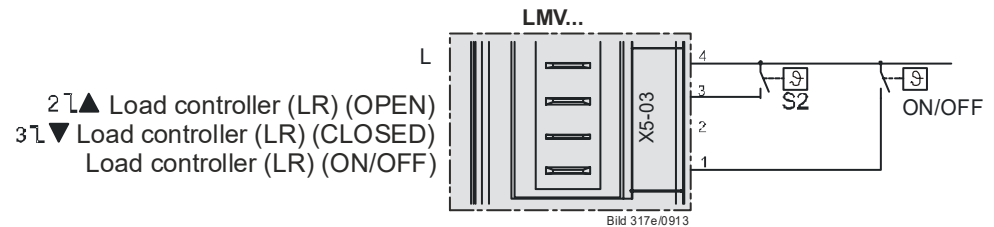

Figure 70: 2-stage operation X5-03

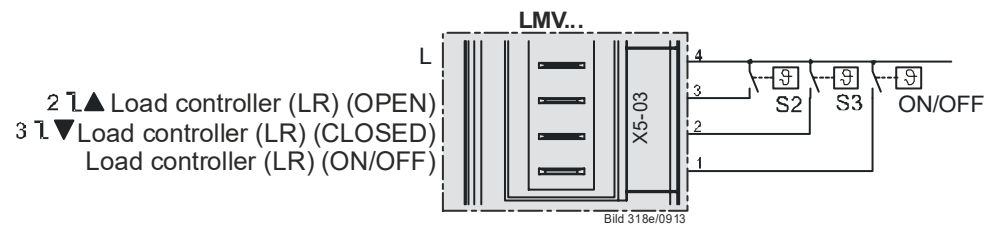

Figure 71: 3-stage operation X5-03

Shifting multistage operation (OPEN pin 3 / CLOSE pin 2)

Using a simple thermostat, a modulating burner can be operated in shifting 2-stage mode. In that case, there must be a firm connection between terminal CLOSE and the live conductor (L), and terminal OPEN must be connected to the thermostat or the load controller.

If OPEN is inactive, the active CLOSE terminal drives the burner to low-fire.

If OPEN becomes active, priority is given over terminal CLOSE so that the output is increased by driving the burner to high-fire.

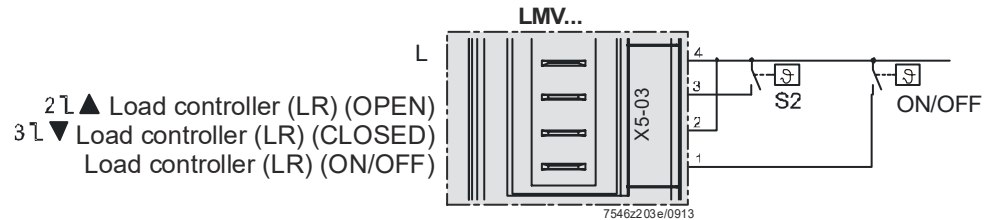

Figure 72: Shifting multistage operation (OPEN pin 3 / CLOSE pin 2)

Parameter 205 is needed to interchange usage of the load controller contacts for multistage operation. In that case, the burner switches to the third stage when input *Stage 2* is active (load controller OPEN). This has no impact on modulating operation.

No.	Parameter
205	Function <i>Load controller contacts multistage</i> 0 = standard 1 = stages interchanged

Modulating		Standard	Stages interchanged
X5-03 pin 1	ON / OFF	Low-fire	Low-fire
X5-03 pin 2	Close	Signal Close	Signal Close
X5-03 pin 3	Open	Signal Open	Signal Open
2-stage		Standard	Stages interchanged
X5-03 pin 1	ON / OFF	Stage 1	Stage 1
X5-03 pin 2	Close	Stage 2	Stage 1
X5-03 pin 3	Open	Stage 2	Stage 2
3-stage		Standard	Stages interchanged
X5-03 pin 1	ON / OFF	Stage 1	Stage 1
X5-03 pin 2	Close	Stage 3	Stage 2
X5-03 pin 3	Open	Stage 2	Stage 3

9.3 Default output via building automation – X92

To control the LMV37.4, the building automation system can predefine an output via a bus system. The building automation system is connected to the LMV37.4 via the X92 interface.

Burner startup can take place only when contact X5-03 pin 1 is closed (load controller ON / OFF).

Further information on connecting the building automation system to the LMV37.4 can be found in this documentation in section *Connection to superordinated systems* and the user documentation Modbus (A7541).

Minimum positioning step

To avoid unnecessary positioning steps of the actuators when the predefined target output varies, a minimum positioning step can be set. The LMV37.4 changes the output only if the change in target output exceeds the minimum positioning step. The minimum positioning step only becomes active in modulating operation.

No.	Parameter
123.0	Minimum output positioning step: Output building automation

Behavior in the event the building automation and control system fails

If the LMV37.4 receives no more data from building automation, it will deliver the output set with parameter 148.

The time that elapses until communication breakdown is detected can be set via parameter 142.

No.	Parameter
142	Setback time in the event of communication breakdown Setting value: 0 = deactivated 1...7200 s
148	Predefined output in the event of communication breakdown with building automation Setting values: For modulating operation , the setting range is as follows: 0...19.9 = burner off 20...100 = 20...100% burner output (20 = low-fire position) For multistage operation , use the following settings: 0 = burner OFF P1...P3 = stage 1...stage 3 Invalid = no output predefined by the building automation system in the event of communication breakdown Default setting: <i>Invalid</i>

Setting choices:

- a) Set output specification in parameter 148 to *undefined* (--).
In the event communication breaks down, the last valid preselected output is maintained. The next load controller activated in accordance with the priority (refer to chapter *Prioritization of load controller sources*) ensures control from this output position.
- b) Output preset via parameter 148 set to 0, 20...100%, or parameterized as multistage:
If communication breaks down, the output requested by the building automation system is set invalid and the output set via parameter 148 is delivered.



Note

In that case, outputs via load controllers with a priority lower than that of the building automation system cannot be delivered.

9.4 Manual output

A manual output can be set with the *Normal display* of the AZL2 or via the PC software ACS410.

Manual output via the AZL2

Manual output can be activated or adjusted by pressing the **F** button for at least 1 second and by pressing the **+** or **-** button.

Output **0** means *Manually OFF*.

As long as the manual output is active, the output appearing on the normal display flashes.

To deactivate and to change to automatic operation, press **ESC** for 3 seconds.

If *Manually OFF* is activated, it is stored via mains OFF.

On power return, the burner assumes the *Manually OFF* position (**OFF** flashing) (refer to chapter *Operation*).

Activation of *Manually OFF* in operation

To activate *Manually OFF*, first run the system to the minimum output limit. Then, press the **F** button for at least 1 second and press the **-** button.

Manually OFF is activated by releasing and pressing again the **F** button and pressing the **-** button.



Caution!

***Manually OFF* must not be used just to put a burner out of operation when doing mounting work, or when the burner is not ready for operation. The safety notes contained in chapter *Safety notes* must be observed!**

Manual output via the PC software ACS410

Refer to description of the PC software ACS410, Software Document (J7352).

9.5 Output with curve settings

To set the curves via the AZL2 or the PC software ACS410, a special parameterization output is provided.

Using this output, it is also possible to approach the point of ignition. The output is delivered automatically and cannot be set manually. It is only mentioned here for the sake of completeness.

9.6 External load controller via analog input X64 pin 1 / X64 pin 2

For the preselection of external outputs, an analog 4...20 mA input is provided. Burner startup can take place only when contact X5-03 pin 1 is closed (load controller ON / OFF).

Switching thresholds / minimum positioning step

A disruption of the current input or a current signal <3 mA leads to deactivation of the analog input's external predefined output.

The behavior of the LMV37.4 in the event of an invalid analog input can be defined. To avoid unnecessary positioning steps of the actuators when the input signal varies, it is possible to set a minimum positioning step for the predefined output. The minimum positioning step only becomes active in modulating operation. For the external load controller via the analog input, a value of 1% is preset.

No.	Parameter
123.1	Minimum output positioning step: Output external load controller analog
204	Behavior if analog input is invalid (4...20 mA) 0 = deactivate default output low-fire / trim function (with warning message) 1 = safety shutdown + startup prevention 2 = deactivate default output low-fire / trim function (without warning message)

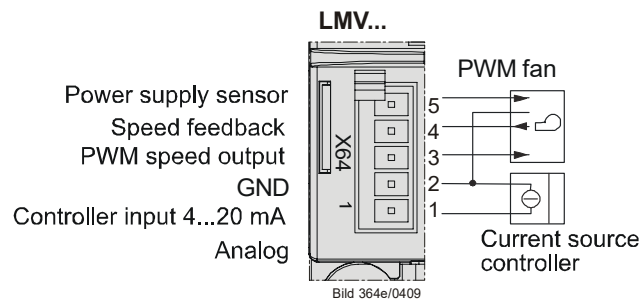

Figure 73: External load controller via analog input X64 pin 1 / X64 pin 2

9.6.1 Switching thresholds for modulating operation

Actual value	Current	Display / output value
Low-fire	3...4 mA	20%
Low-fire	4 mA	20%
High-fire	20 mA	100%

9.6.2 Switching thresholds for multistage operation

For multistage operation, a hysteresis band about the thresholds is introduced. This hysteresis band replaces the minimum positioning step used in multistage operation. The band width is approx. 1 mA.

2-stage operation

Actual value	Current	Display / output value
Stage 1	5 mA (3...12 mA)	P1
Hysteresis band	12...13 mA	---
Stage 2	15 mA (13...20 mA)	P2

3-stage operation

Actual value	Current	Display / output value
Stage 1	5 mA (3...7 mA)	P1
Hysteresis band 1	7...8 mA	---
Stage 2	10 mA (8...12 mA)	P2
Hysteresis band 2	12...13 mA	---
Stage 3	15 mA (13...20 mA)	P3

9.7 Prioritization of load controller sources

To simplify configuration of the LMV37.4, the load controller source need not be selected. The LMV37.4 automatically detects the available load controller sources and selects them. If several sources are used, they are selected according to the following priorities:

Parameter 942	Priority	Active load controller source
	1 highest	Chapter <i>Load controller ON-contact X5-03, pin 1</i> When the input is activated, the other load controller sources are assessed according to their priorities. When the input is deactivated, the burner is off
1	2	Chapter <i>Load output with curve settings</i>
2	3	Chapter <i>Manual output</i>
3	4	Chapter <i>Default output via building automation X92</i>
4	5	Chapter <i>External load controller via analog input X64 pin 1/pin 2</i>
5	6 lowest	Chapter <i>External load controller via contacts X5-03, pin 2/pin 3</i>



Note!

When the *Switching back to pilot* function is used, the load controller inputs OPEN CLOSE (X5-03 pin 2 and 3) are not available (refer to chapter *Switching back to pilot*). Analog input X64 is used as the load controller source in this case.

The active load controller source can be read out via parameter 942.

No.	Parameter
942	Active load controller source 1 = output during curve settings 2 = manual output 3 = default output via building automation 4 = default output via analog input 5 = external load controller via contacts

9.7.1 Emergency operation with several load controller sources

By making use of the prioritization described above, it is also possible to implement emergency operation. Should the building automation and control LMV37.4 fail (provided parameter 148 is set to undefined (--)), the unit switches automatically over to the external load controller.

A load controller can be connected via analog input or – if existing – via contacts.

No.	Parameter
148	<p>Predefined output in the event of communication breakdown with building automation</p> <p>Setting values: For modulating operation, the setting range is as follows: 0...19.9 = burner off 20...100 = 20...100% burner output (20 = low-fire position)</p> <p>For multistage operation, use the following settings: 0 = burner OFF P1...P3 = stage 1...stage 3</p> <p>Invalid = no output predefined by the building automation system in the event of communication breakdown</p> <p>Default setting: <i>Invalid</i></p>

9.7.2 Manual control

If the external load controller via contacts is not used, a simple manual output adjustment via switch can be implemented by cutting the connection to the load controller for switching from automatic to manual operation. In that case, the LMV37.4 switches to the external load controller via contact. A switch for Open/Close or stage 2/stage 3 can then be connected to the load controller's terminals.

10 Electronic ratio control

10.1 General

Electronic ratio control is used to control the burner's actuators depending on burner output. It is possible to connect 2 actuators and, optionally, 1 VSD. Resolution is 0.1° with the actuators and 0.1% with the VSD. Output can be regulated in increments of 0.1% in modulating mode and with a maximum of 3 stages in multistage mode.

To reduce the electric power required for the actuators, they are never operated simultaneously, but in successive order, or alternately.

10.2 Behavior outside the operating positions

Outside their operating positions, the actuators approach the different positions in successive order.

The program phase determines the position to be approached.

10.2.1 Traveling speed

The running speed of the actuators is fixed at 5 seconds for a positioning angle of 90° for SQM33.4, SQM33.5, and SQN1.

The speed is 10 seconds for a positioning angle of 90° for SQM33.6.

The SQM33.7 requires 17 seconds for a positioning angle of 90°.

The ramp speed of the VSD can be adjusted separately for higher and lower speeds.

No.	Parameter
522	Ramp up
523	Ramp down

The setting also applies to the operating position (refer to chapter *Operating position*).

10.2.2 Home position

This position is approached in the *Home run* (10), *Standby* (12) and *Lockout position* (00) phases.

The position can be set via the following parameters:

Parameter	Actuator
501.00	Idle position fuel actuator
502.00	Idle position air actuator
503.00	Idle speed VSD

10.2.3 Prepurging

This position is approached in phase *Traveling to prepurging* (24).

The position can be set via the following parameters:

Parameter	Actuator
501.01	Prepurge position fuel actuator
502.01	Prepurge position air actuator
503.01	Prepurge speed VSD

No.	Parameter
222	Gas: Prepurging 0 = inactive 1 = active
262	Oil: Prepurging 0 = inactive 1 = active

10.2.4 Ignition

The ignition position is approached in phase *Traveling to the ignition position* (38).
The position is set via curve parameterization under **P0**. In modulating operation, this point is assigned to an output of 10%.

10.2.5 Postpurging

This position is approached in phase *Traveling to postpurging* (72).

The position can be set via the following parameters:

Parameter	Actuator
501.02	Postpurge position fuel actuator
502.02	Postpurge position air actuator
503.02	Postpurge speed VSD

10.3 Modulating operation

In modulating mode, it is possible to operate 2 actuators and 1 VSD. The burner's output can be regulated between 20% (low-fire) and 100% (high-fire) in increments of 0.1%. Since the actuators are never allowed to operate simultaneously, the output is increased in small steps of 1%. With a ramp-up time of 32 seconds in operating position (from 20% to 100%), this results in a step within 400 ms. Within such an output step, the air actuator or the VSD is operated in the first 200 ms, and the fuel actuator in the second 200 ms.

10.3.1 Definition of curves

The air-fuel ratio curves are defined by 10 curvepoints that are fixed and distributed across the output range.

The following assignment applies:

Curvepoint	Output	Meaning
P0	10%	Point of ignition, not approached in the operating position
P1	20%	Low-fire
P2	30%	
P3	40%	
P4	50%	
P5	60%	
P6	70%	
P7	80%	
P8	90%	
P9	100%	High-fire

The actuator positions can be set with a resolution of 0.1°.

Between the curvepoints, the positions are interpolated in a linear manner.

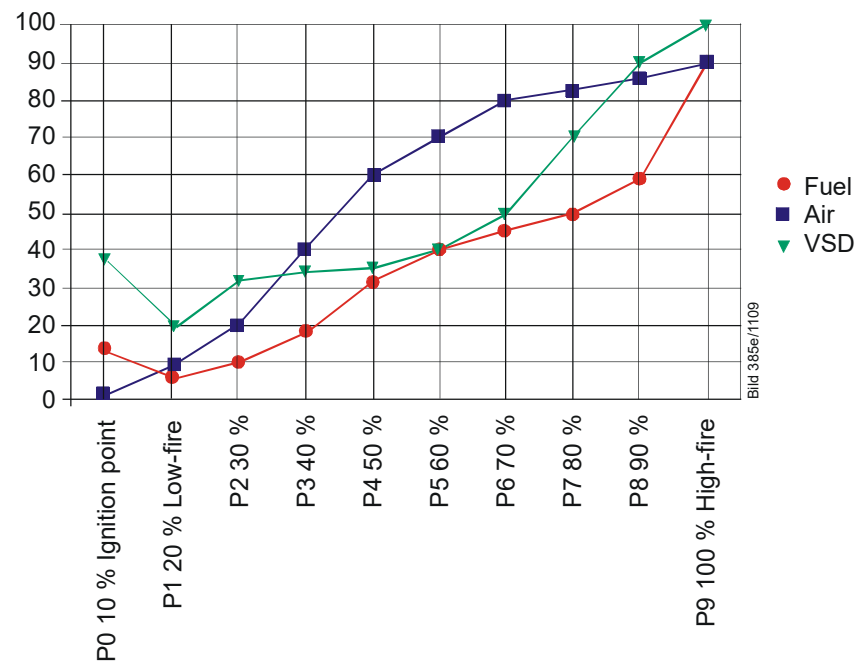

Figure 74: Definition of curves

No.	Parameter
401	Fuel-air ratio control curve fuel actuator (curve setting only)
402	Fuel-air ratio control curve air actuator (curve setting only)
403	Fuel-air ratio control curve VSD (curve setting only)

10.3.2 Traveling speed / maximum curve slope

The rise time required to modulate from low-fire to high-fire can be set via parameter 544.

The following maximum curve slopes (positioning angle) can be achieved depending on the set ramp-up time (parameter 544):

Type of actuator	Positioning speed	Modulation 16 s	Modulation 32 s	Modulation 48 s	Modulation 64 s	Modulation 80 s
		Positioning angle ²⁾	Positioning angle ²⁾	Positioning angle ²⁾	Positioning angle ²⁾	Positioning angle ²⁾
Actuators (3 Nm)	5 s / 90°	15°	31°	46°	62°	77°
Actuator SQM33.6	10 s / 90°	7° ¹⁾	15°	22°	30°	37°
Actuator SQM33.7	17 s / 90°	4° ¹⁾	9° ¹⁾	13°	18°	22°
VSD	5 s / 100%	20%	40 %	60 %	80 %	100 %
	10 s / 100%	10%	20 %	30 %	40 %	50 %
	20 s / 100%	5% ¹⁾	10 %	15 %	20 %	25 %
	30 s / 100%	3.3% ¹⁾	6,6 % ¹⁾	10 %	13 %	16 %
	40 s / 100%	2.5% ¹⁾	5 % ¹⁾	7.5 % ¹⁾	10 %	12 %

¹⁾ Depending on the setting, the restriction of the maximum positioning angle does not permit the maximum position of 90° to be reached

²⁾ Maximum difference between 2 curve points

No.	Parameter
522	Ramp up
523	Ramp down
544	Ramp modulating
647	No-load time for speed measurement in modulating operation [25 ms]

The setting also acts outside the operating position (refer to chapter *Traveling speed*).

VSD / PWM fan

For the VSD or the PWM fan, it is also possible to change the maximum speed differential between 2 curvepoints via the no-load time for the speed measurement in modulating operation. This is 200 ms (value 8) in the default setting and can be reduced to 100 ms (value 4). Shortening the no-load time can result in problems in connection with the internal speed control of the LMV37.4 and is only recommended with the control deactivated.

The achievable maximum speed difference can be calculated based on the following formula:

$$\text{Maximum speed differential} = \frac{100\% * \text{modulating operating ramp} * (16 - \text{no-load time speed measurement})}{(\text{Ramp time} * 128)}$$

Between the ignition time (P0) and the low-fire point (P1), a speed differential of up to 40% can be set for the VSD or the PWM fan, independent of the selected ramp. This means that the period of time from ignition to low-fire can vary between 4...32 seconds (5...40 seconds ramp).

Error code	Diagnostic code	Meaning for the LMV37.4
84	Bit 0 Valency 1	VSD: Curve too steep in terms of ramp rate
	Bit 1 Valency 2..3	Fuel actuator: Curve too steep in terms of ramp speed
	Bit 2 Valency 4..7	Air actuator: Curve too steep in terms of ramp speed

The parameterized curve is steeper than is permitted at the selected actuator speed.

10.3.3 Entering the running position

The burner is ignited when ignition position **P0** is reached. When entering operating phase **60**, the actuators follow the defined curves until the low-fire position is reached (20% or parameter 545).

No.	Parameter
545	Lower output limit undefined = 20 %

10.3.4 Operating position

As demanded by the load controller, the actuators are driven along the defined 20% and 100% curves. Point of ignition **P0** can only be reached via the curve settings.

10.3.5 Limitation of modulation range

If the modulation range shall be further restricted from 20 to 100% against the defined curve, 2 parameters are available to define a new low-fire and high-fire position.

No.	Parameter
545	Lower output limit undefined = 20 %
546	Upper output limit undefined = 100 %

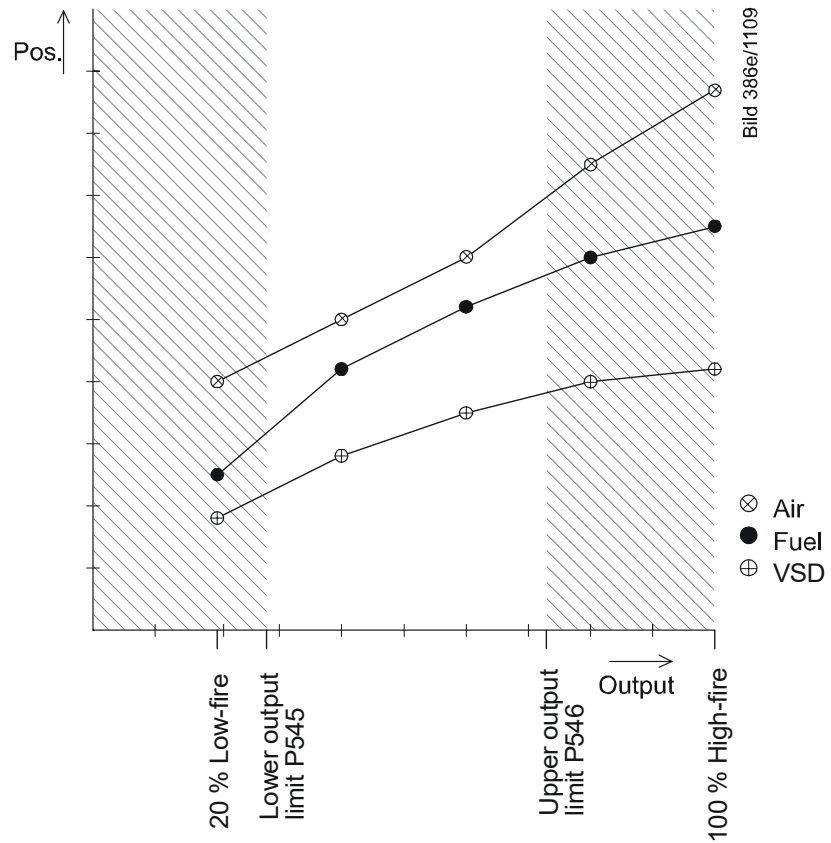

Figure 75: Restriction of modulation range

10.3.6 Setting the minimum and maximum output

When changing the setting of minimum and maximum output after making the curve settings, following is to be observed:

After leaving the curve settings with completely defined curvepoints, proceed in modulating operation by setting the minimum / maximum output (parameter 546).

In case of the warm setting, the parameterized output remains active until setting of the minimum / maximum output is completed. Any change to the minimum / maximum output is included in the parameterized output.

Automatic operation is only activated once the minimum/maximum output setting is exited.

As a result of this procedure, the LMV37.4 maintains the output set by the user, thus ensuring **trouble-free** setting of the minimum / maximum output.

Advantages:

- The actual output always corresponds to the currently parameterized minimum / maximum output or the system output resulting from the curve setting made last, which means that the output can be ascertained accurately and without interference
- The low-priority load controller sources (contacts, analog input, output specification of a building automation and control system, manual output) are inactive
- Manual OFF function is inactive during curve setting and subsequent minimum / maximum output setting
- Unambiguous and easy-to-understand behavior of the system



Note

If there is no need to limit the output, it is not necessary to set the minimum / maximum output. In that case, the undefined minimum / maximum output corresponds to a minimum output of 20% and a maximum output of 100%.

No.	Parameter
546	Upper output limit undefined = 100%

10.4 Multistage operation

This operating mode is only available when firing on oil. There is a choice of 2-stage and 3-stage operation. Hence, the burner's output can be modulated via 2 or 3 stages. Modulation is accomplished by adjustment of the air actuator or the VSD and by switching the fuel valves for adjusting the amount of fuel.

10.4.1 Definition of curves

Fuel-air ratio control is defined via the 2 or 3 static output points. To switch the valves on and off, switch-on and switch-off points must be defined.

The following assignments apply:

Curve-point	Meaning	Valve
P0	Point of ignition (not approached in the operating position)	V1
P1	Stage 1	V1
P2on	Switch-on point stage 2. When the angle exceeds this point, the fuel valve for the second stage is switched on	V1
P2_d	Presetting of point P2 with no approach	V1
P2	Stage 2	V2
P2of	Switch-off point stage 2. When the angle falls below this point, the fuel valve for the second stage is switched off	V2
P3on	Switch-on point stage 3. When the angle exceeds this point, the fuel valve for the third stage is switched on	V2
P3_d	Presetting of point P3 with no approach	V2
P3	Stage 3	V3
P3of	Switch-off point stage 3. When the angle falls below this point, the fuel valve for the third stage is switched off	V3

The actuator positions can be set with a resolution of 0.1°, the speeds with a resolution of 0.1%.

10.4.2 Traveling speed

The air actuator or the VSD is operated like outside the operating position. The defined ramp speeds are used.

The speed of the VSD can be adjusted separately for speed increase or decrease.

No.	Parameter
522	Ramp up
523	Ramp down

The setting also acts outside the operating position.

The running speed of the actuators is fixed at 5 seconds for a positioning angle of 90° for SQM33.4, SQM33.5, and SQN1.

The speed is 10 seconds for a positioning angle of 90° for SQM33.6.

The SQM33.7 requires 17 seconds for a positioning angle of 90°.

10.4.3 Adjustment of output

When the output increases, the LMV37.4 moves from the curvepoint of stage 1 (P1) to the switch-on point of stage 2 (P2on). If the switch-on point is exceeded, the valve for the second stage is switched on. Then, the LMV37.4 moves to the curvepoint for stage 2 (P2). When the output decreases, the LMV37.4 moves from the curvepoint of stage 2 (P2) to the switch-off point of stage 2 (P2of). If this point is crossed, the valve for the second stage is switched off. Then, the LMV37.4 moves to the curvepoint for stage 1 (P1).

In 3-stage operation, the output between stage 2 and stage 3 is adjusted analogously to 2-stage operation. As static outputs, only **P1**, **P2** and **P3** can be approached.

The switch-on and switch-off points are crossed only when changing between stages. The traveling speeds are fixed. Depending on the positioning angles to be covered, air actuator and VSD do not reach the operating or switch-on/switch-off points at the same time. The valves are switched on / off only after the actuators have reached their correct positions.

When parameterizing the curves, the switch-on points can also be approached in a stationary manner. In addition, when setting the curve via $P2_d$ ($P3_d$), curvepoint $P2$ ($P3$) can be readjusted without traveling to it. In that case, the LMV37.4 is at the respective switch-on point. This procedure is used to reduce the operating time if there is shortage of air.

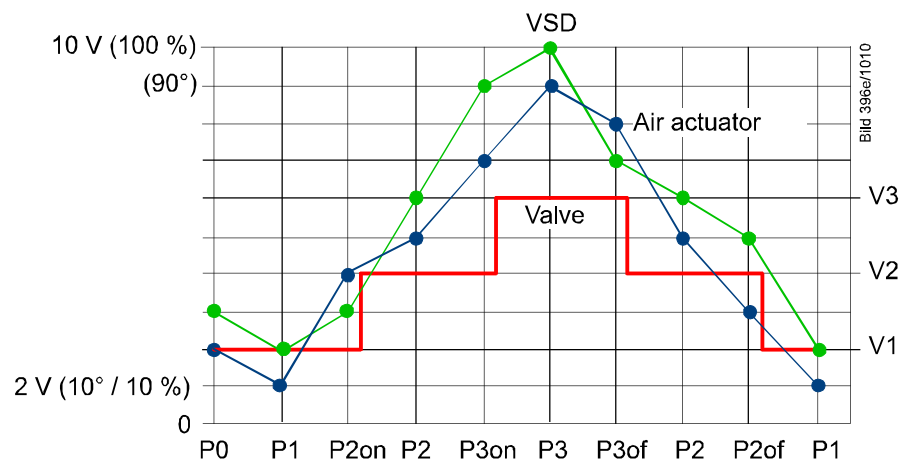

Figure 76: Adjustment of output

10.4.4 Entering the operating position

The burner is ignited at ignition position **P0**. When entering operating phase **60**, the actuators are driven from ignition position **P0** to the operating point of stage 1 (P1) at the respective traveling speed.

10.4.5 Operating position

In the operating position, the burner's output can be adjusted between operating points **P1** and **P2** or **P3** in accordance with the load controller's presetting, as described in chapter *Adjustment of output*. Ignition position **P0** is not approached anymore. It can only be reached via curve adjustment.

10.4.6 Limitation of modulation range

If the modulation range for stage 1 and stage 2, or stage 3, shall be further restricted, 2 parameters can be used to define a new low-fire and high-fire position.

No.	Parameter
545	Lower output limit undefined = 20 %
546	Upper output limit undefined = 100 %

10.5 End of operating position

When there is no more heat request, the LMV37.4 switches to phase 62. Here, the burner runs down to low-fire as long as possible before the valves are shut. The available period of time can be set via parameter 212. If this time is set to the minimum value, the burner is immediately shut down if there are no more requests for heat. If the time exceeds 32 seconds, the burner always runs to low-fire. Naturally, it is also possible to set intermediate times.

No.	Parameter
212	Maximum time down to low-fire

10.6 Notes on settings and parameter settings

- When making the settings for the electronic fuel-air ratio control system integrated in the LMV37.4, it must be ensured that sufficient amounts of excess air are available because over a period of time, the flue gas values are impacted by a number of factors, such as air density, wear of actuators and controlling elements, etc. For this reason, the flue gas values initially set must be checked at regular intervals
- To safeguard against accidental or unauthorized transfer of parameters from the parameter backup of the ACS410 to the LMV37.4, the OEM (burner or boiler manufacturer) must enter an **individual burner identification** for every burner. Only when this requirement is satisfied does the LMV37.4 make certain that the ACS410 does not transfer a parameter set from a plant (with unsuited and possibly dangerous parameter values) to the LMV37.4
- With the LMV37.4, it should be noted that the unit's characteristics are determined primarily by the parameter settings and not so much by the type of LMV37.4. This means that – among other considerations – the parameter settings must always be checked prior to commissioning the plant, and that the LMV37.4 must never be transferred from one plant to another without adapting its parameters to the new plant
- When using the ACS410 PC software, the safety notes given in the relevant Operating Instructions (J7352) must also be observed
- The parameter level is password-protected. The OEM assigns individual passwords to the parameter levels he can access. The unit is supplied with default passwords entered by Siemens; they must be changed by the OEM. These passwords are confidential and may be assigned to authorized personnel only
- Confidential and may only be assigned to authorized staff
- The responsibility for setting parameters is assumed by the person who, in accordance with the access rights, has made changes on the respective setting level

In particular, the OEM assumes responsibility for the correct parameter settings in compliance with the standards covering the specific applications (e.g. EN 267, EN 676, EN 1643, etc.).

11 Actuators X53 / X54

One or 2 actuators can be connected to the LMV37.4, depending on the selected operating mode (refer to chapter *Selection of operating mode*).



Caution!

When mounting the actuators, it must be made certain that the mechanical link to the controlling elements is rigid!

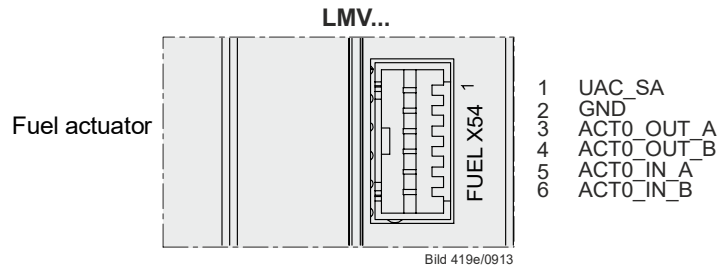

Figure 77: Fuel actuator (X54)

The actuators are suited for direct connection to the LMV37.4.

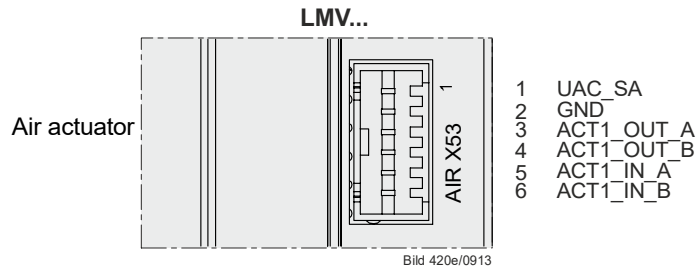

Figure 78: Air actuator (X53)

11.1 Function principle

The actuators are driven by stepper motors. The resolution reached when making 1 positioning step is 0.1°.

The running speed of the actuators is fixed at 5 seconds for a positioning angle of 90° for SQM33.4, SQM33.5, and SQN1.

The speed is 10 seconds for a positioning angle of 90° for SQM33.6.

The SQM33.7 requires 17 seconds for a positioning angle of 90°. An optical incremental transducer is used to monitor the current position. Due to the use of a gear train with almost no backlash, position control is not required.

11.2 Definition of angles

The angles and angular ranges are specified in the Data Sheets of the relevant actuators.

SQM33: Refer to Data Sheet N7813.

SQN1: Refer to Data Sheet N7803.

Also refer to figure *Angle definitions with SQM33*.

11.3 Referencing

An incremental transducer is used for position feedback. This means that referencing of the actuators must be performed after power-ON. In addition, at the end of each shutdown in phase 10, the actuators are referenced to ensure that individual stepping errors, which could lead to shutdown, do not accumulate. If a position error occurs, the LMV37.4 switches to the safety phase (phase 01), enabling the actuators with detected position errors to be referenced. During the following phase 10, the only actuators referenced are those that were not referenced before in the safety phase (phase 01). The position of the reference point can be selected depending on the type of burner, either the *Closed* position ($<0^\circ$) or the *Open* position ($>90^\circ$).

When using actuators SQM33.6 or SQM33.7, the actuator type (parameter 613) must be set (refer to chapter *Actuator type / running time*).



Note!

If a SQM33.7 is used, the modulating operating ramp (parameter 544) may need to be increased (refer to chapter *Running speed / maximum curve slope*).

No.	Parameter
544	Ramp modulating
601	<p>Selection of reference point Index 0 = fuel Index 1 = air</p> <p>Setting values: 0 = closed (<0°) 1 = open (>90°)</p>
602	<p>Actuator's direction of rotation Index 0 = fuel Index 1 = air</p> <p>Setting values: 0 = counterclockwise 1 = clockwise (exclusively for SQM3)</p>
603	<p>Tolerance limit of position monitoring (0.1°) Index 0 = fuel Index 1 = air</p> <p>Greatest position error where an error is securely detected → Error detection band: (parameter 606 -0.6°) up to parameter 606</p>
611	<p>Type of reference Index 0 = fuel Index 1 = air</p> <p>Setting values: 0 = standard 1 = range stop in the usable range 2 = internal range stop (SQN1) 3 = both</p>
613	<p>Type of actuator Index 0 = fuel Index 1 = air</p> <p>Setting values: 0 = 5 s / 90° (1 Nm, 1,2 Nm, 3 Nm) 1 = 10 s / 90° (6 Nm) 2 = 17 s / 90° (10 Nm)</p>



Application note!

Single-sided load torque is recommended due to the type of gear train for the SQM33.6 / SQM33.7 actuators. In the event of load on both sides, a backlash of $\pm 0.3^\circ$ must also be considered in addition to plant design or setting

11.3.1 Reference travel

Reference travel means that different reference travels are performed, aimed at unambiguously determining the actuators' permissible working range. This prevents the actuators from traveling to a range outside the optical feedback system or against a mechanical stop should a power failure during referencing occur. Parameter 611 must be set depending on the mechanical construction and the type of actuator used.

In the case of reference travel type 1, the SQM33 actuator first travels to the starting point.



Note!

Always select reference travel type 2 for SQN13 and SQN14.

Parameterization for reference travel type 0 and type 2

No.	Parameter	Setting for actuator		
		SQM33	SQN13	SQN14
611	Type of referencing			
	Index 0 = Fuel	0	2	2
	Index 1 = Air	0	2	2

Parameterization for reference travel type 1

No.	Parameter	Setting for actuator type ...		
		SQM33		
611	Type of referencing			
	Index 0 = fuel	1		
	Index 1 = air	1		

To prevent the actuator from running against a mechanical stop during referencing, the home position may have to be adjusted (depending on the direction of rotation and a reference point of about 3° or 87°). In the case of stops within the usable range, the prepurge or postpurge position must be checked also.

Refer to the figure below for details of the reference travel.

Example of actuator with counterclockwise rotation:

When referencing in the *Close* position, the actuator first travels a certain distance into the working range (toward the *Open* position). Then, it travels to a position representing maximum -7.7° , thereby crossing the reference mark for the first time. Then, the actuator moves in the other direction again and detects the inner ramp of the reference mark. This is the reference point used by all positions. If the reference point is parameterized in the *Open* position, referencing takes place in a mirror-symmetrical manner. In that case, the actuator first travels into the working range (toward the *Open* position). Then, it crosses the reference mark and travels to a position representing maximum 110.6° , then back to the inner ramp of the reference mark.

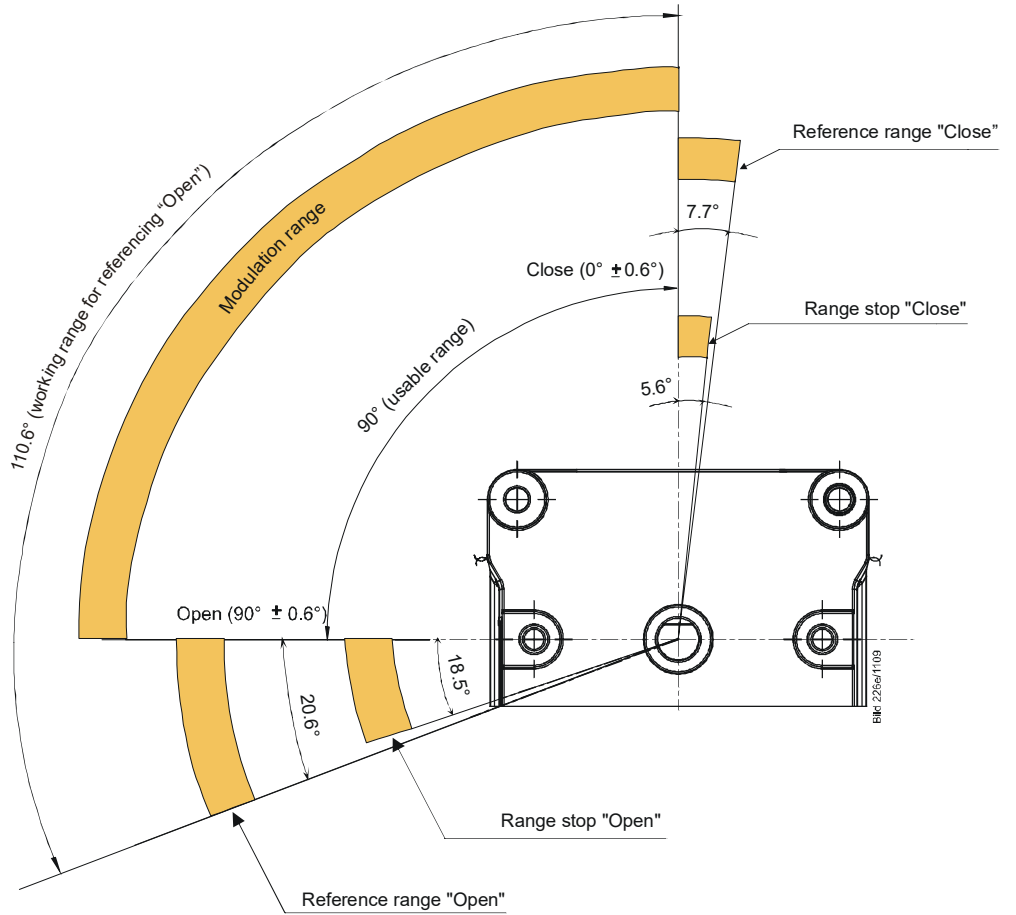

Figure 79: Angle definitions with SQM33

Error code	Diagnostic code	Meaning for the LMV37.4
85	0	Referencing error of fuel actuator
	1	Referencing error of air actuator
	Bit 7 Valency ≥128	Referencing error due to parameter change

11.4 Direction of rotation

With the SQM3 actuator, the direction of rotation can be selected on an individual basis.

No.	Parameter
602.00	Actuator's direction of rotation Index 0 = fuel Setting values: 0 = counterclockwise 1 = clockwise (exclusively for SQM3)
602.01	Actuator's direction of rotation Index 1 = air Setting values: 0 = counterclockwise 1 = clockwise (exclusively for SQM3)

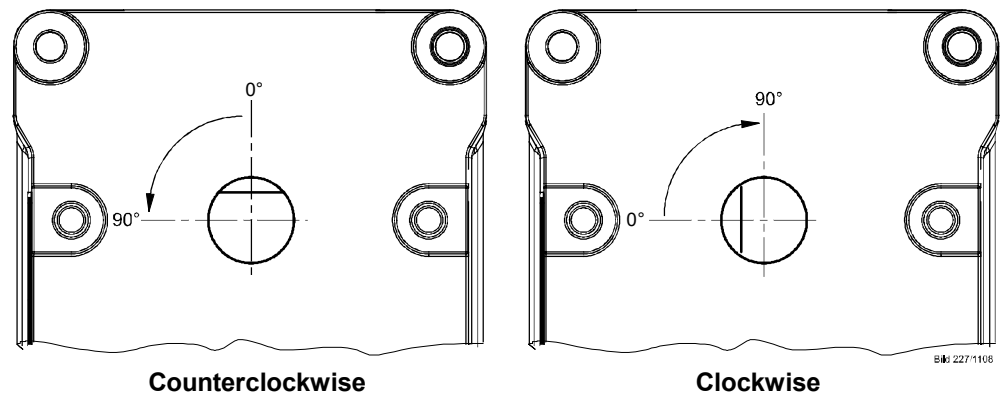

Figure 80: Direction of rotation (example SQM3)

The direction of rotation of the SQN1 actuators depends on the version:

- SQN13: Direction of rotation *Left*
- SQN14: Direction of rotation *Right*



Note

The actuators are always supplied with the flat of the drive shaft facing upward.

11.5 Monitoring the actuator positions

To monitor the actuator's current positions, an optical incremental transducer with a resolution of 0.7° is used. The correct position of the drive shaft is ensured by comparing the motor steps made with the position obtained from the incremental transducer. Due to the different resolutions of motor steps and incremental transducer plus the selected tolerance band, the following error detection band is obtained. The position where – in the error detection band – shutdown takes place depends on the position currently required.

For the default setting made in the factory, the error detection band is as follows:

Smallest position error where an error can be detected	1.1°
Greatest position error where an error is securely detected (default setting parameter 606)	1.7°

The presetting of 1.7° (default setting, parameter 606) is suited for use with actuators type SQN1 and SQM3.



Note

When using SQN1 actuators equipped with plastic gear trains, we recommend to change the preset values as follows:

Product no.	Value
SQN13.14	1,7°
SQN14.14	1,7°
SQN13.17	2,2°
SQN14.17	2,2°

When referencing under output conditions, the resilience of the actuator's gear train must also be taken into consideration:

Product no.	Resilience at max. rated driving torque
SQM33.41	0.2°
SQM33.51	0.2°
SQM33.6	0.2°
SQM33.7	0.2°
SQN13.14	0.3°
SQN13.17	0.8°
SQN14.14	0.3°
SQN14.17	0.8°

The error detection time is <1 second.



Caution!

This means that – for the design and setting of the burner – a position error resulting from the sum of...

- greatest position error from which an error is detected in all positions,
- resilience at the max. rated torque, and
- mechanical influence from the link between actuator and regulating unit (e.g. coupling)

must not lead to a critical state in terms of safety.

No.	Parameter
606	Tolerance limit of position monitoring (0.1°) Index 0 = fuel Index 1 = air Greatest position error where an error is securely detected → error detection band: (parameter 606 -0.6°) up to parameter 606

Error code	Diagnostic code	Meaning for the LMV37.4
86	0	Position error fuel actuator
87	0	Position error air actuator

11.6 Changing the error detection band for monitoring the actuator positions

The error detection band can be changed via parameter 606. A change is to be made only when using SQN13.17 or SQN14.17 actuators which, due to their mechanical design, require greater tolerances. For these types of actuators, set parameter 606 to 2.2°.

No.	Parameter
606	Tolerance limit of position monitoring (0.1°) Index 0 = fuel Index 1 = air Greatest position error where an error is securely detected → Error detection band: (parameter 606 -0.6°) up to parameter 606

11.7 Forced travel

There are errors in the actuators' feedback unit which can only be detected in connection with position changes. To be able to also detect such errors when maintaining the same position for longer periods of time, travel is enforced when – for more than 50 minutes – an actuator moves no more than 2.8°. With forced travel, both actuators are driven 2.8° in the direction of smaller positioning angles and back again to the initial angular position. If a damper is less than 2.8° open, the actuator is driven in the direction of positive angles in order not to run against mechanical stops, if present. Forced travel lasts a total of 1 second.

11.8 Detection of line interruptions

The connecting line ensuring position feedback from the actuator to the LMV37.4 is monitored for interruptions, which means that position feedback cannot fail without being noticed.

Error code	Diagnostic code	Meaning for the LMV37.4
86	Bit 0 Valency 1	Line interruption fuel actuator
87	Bit 0 Valency 1	Line interruption air actuator

11.9 Protection against actuator mixup

Mixup of actuators can be detected through appropriate mounting (using different reference marks for the air and fuel actuator: Open/Close/0°/90°). With at least one of the actuators, the reference mark not used must be blocked by a mechanical stop. Now, if the actuator connections with the LMV37.4 have been interchanged, one of the actuators cannot reach the reference mark, which is detected by the LMV37.4. Protection against mixup is a question of burner application and must be ensured by the OEM.



Caution!

To be able to detect mixup of actuators, the burner manufacturers must ensure that the 2 actuators use opposing reference points. One of the actuators uses the OPEN reference, the other the CLOSED reference. Approach of the reference point not used must be blocked with at least one of the actuators!

11.9.1 Proposal for implementation

- Parameterize referencing of the air damper in the CLOSED position
- Parameterize referencing of the fuel damper in the OPEN position. Unnecessary travel can be avoided by defining a home position of **90°** for the fuel damper
- Mechanical stop at the air damper in the range between 90° and 108.5°, and / or mechanical stop at the fuel damper in the range between 0° and -5.6°

Referencing process

- From any position in the working range (0...90°), but typically from the home position, the air damper travels to the **-7.7°** position and back again to the home position
- From any position in the working range (0...90°), but typically from the home position, the fuel damper travels to the **110.6°** position and back again to the home position

Process in the event of mixup

- The fuel damper (fitted in place of the air damper) travels to the **-7.7°** position and back again to the home position
- The air damper (fitted in place of the gas damper) tries to travel to the **110.6°** position, but is prevented from doing so by the mechanical stop. This is unsuccessful travel and identified as mixup

12 Fan control

12.1 Function principle

Optionally, the LMV37.4 can be operated with a VSD or PWM fan. The activation takes place via a DC 0...10 V or alternatively via a PWM interface. For control of the fan's speed, a safety-related speed feedback signal is required. With pneumatic fuel-air ratio control, the speed feedback signal is not evaluated as standard. It is, however, possible to define additional limit thresholds for supervising the fan speed during prepurging, ignition and operation. To facilitate the use of fans with different speed ranges, the fan's speed is standardized between 0...100% (up to 14000 rpm is supported as the maximum fan speed). If fan control is not connected, a load output and, alternatively, a fuel meter output are available (refer to chapters *Load output X74 pin 3* and *Fuel meter input X75 pin 1 / X75 pin 2*).

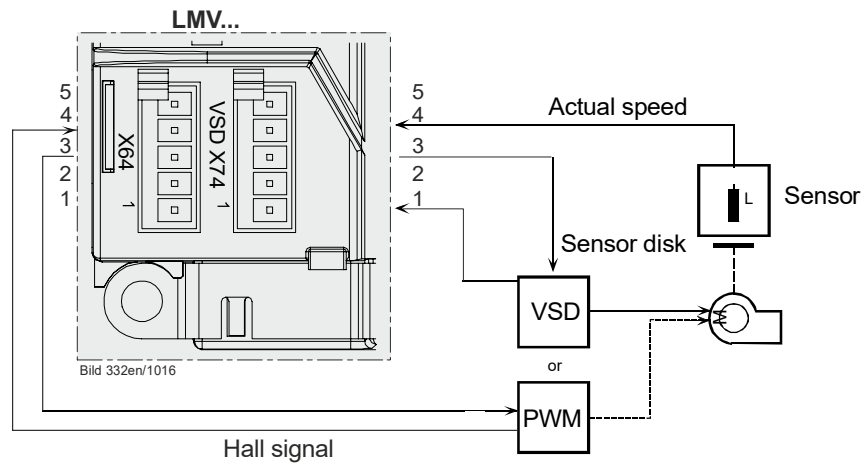

Figure 81: Function principle of VSD

12.2 Activation of VSD/PWM fan

The VSD can be activated in any of the operating modes (parameter 201).

No.	Parameter
542	Activation of VSD / PWM fan 0 = deactivated 1 = active 2 = activated (No restart)



Note
 For configuration of the analog output when the VSD is activated, refer to chapter *Power output X74 pin 3!*

12.3 VSD control X74 pin 3

The VSD is controlled via a voltage interface (refer to chapter *Load output X74 pin 3*)!

Depending on the type of VSD used, a release contact is required. This contact can be controlled via the fan motor contactor. To enable the VSD to bring the fan motor's speed to the correct no-load speed, the motor contactor's drop out delay time must be about 25 seconds.

Example:

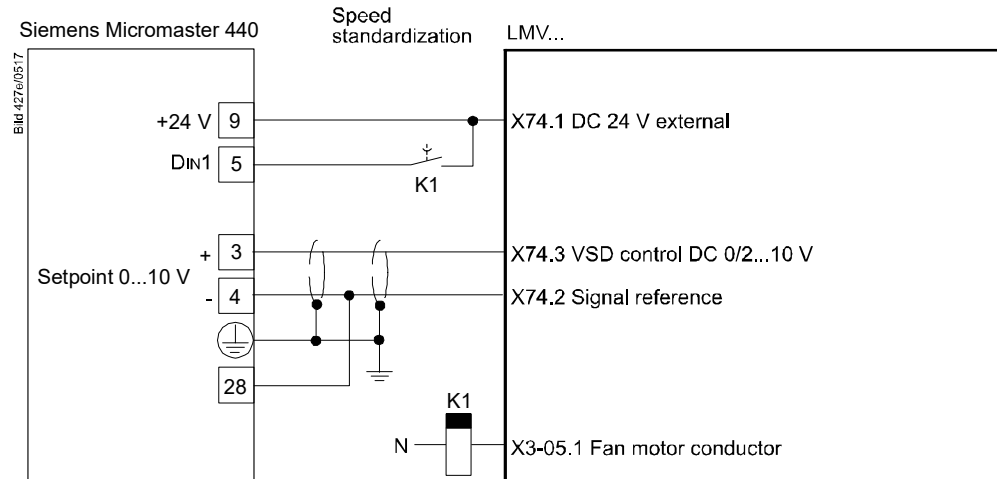

Figure 82: Connection of VSD to the LMV37.4

It is possible to set the VSD control to 0 via the analog output when the safety loop is open (including burner flange switch).

This may be necessary if the no-load speed is not 0.

No.	Parameter
652	VSD behavior when safety loop / burner flange is open 0 = no VSD control when safety loop / burner flange is open 1 = VSD control independent of safety loop / burner flange

12.4 PWM fan control X64 pin 3

The PWM fan is controlled via PWM voltage interface X64 pin 3.



Caution!

A PWM fan can only be used in the factory settings in conjunction with pneumatic fuel-air ratio control!

A PWM fan motor can only be used in the electronic fuel-air ratio control system with a self-regulated PWM fan (see chapter *Speed control*).

12.5 Safe separation of mains voltage and protective extra low-voltage



Caution!

All inputs and outputs of PWM fan control are designed for use with protective extra low-voltage. For this reason, strict separation from the mains voltage side must be ensured!

This necessitates an external power supply by the VSD or an external power pack (X74 pin 1, X74 pin 2).

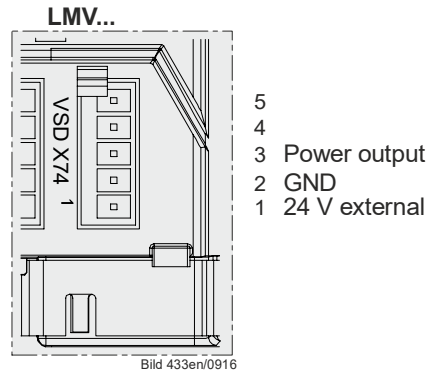

Figure 83: Power output



Note

Power must also be supplied via X74 pin 1 / pin 2 in the case a PWM fan is used.

12.6 Ramp time

The ramp time for fan control can be set separately for acceleration and deceleration (also refer to chapter *Traveling speed/maximum curve slope*).

No.	Parameter
522	Ramp up
523	Ramp down
544	Ramp modulating

If shutdown occurs because the speed has not been reached, the VSD/fan motor might not be able to follow quickly enough the set ramp.

In the case of a ramp time >20 seconds, the modulating operating ramp (parameter 544) must be increased (refer to chapter *Running speed / maximum curve slope*).

Remedy:

Shorten further the ramp of the VSD/fan motor or increase the ramp in the LMV37.4 (parameters 522/523) (also refer to chapter *Traveling speed/maximum curve slope*).

For VSD operation



Caution!

The ramps parameterized for the VSD should be at least 20% shorter than the ramps in the LMV37.4.

Example:

5 s ramp	LMV37.4	4 s ramp VSD
10 s ramp	LMV37.4	8 s ramp VSD
20 s ramp	LMV37.4	16 s ramp VSD
40 s ramp	LMV37.4	32 s ramp VSD

12.7 Acquisition of speed

12.7.1 Acquisition of speed with proximity switch

The actual speed is acquired by an inductive proximity switch which scans a metal sensor disk. The sensor disk must be attached directly to the motor's drive shaft. Speed acquisition is safety-related. To facilitate the detection of the direction of rotation and to be able to make the plausibility check with only 1 sensor, a sensor disk with angular steps of 60°, 120° and 180° is used. It generates 3 pulse intervals of different length.

Speed acquisition is designed for the connection of different types of sensors.



Caution!

With electronic fuel-air ratio control, speed acquisition is safety-related!

We recommend using the AGG5.310 accessory set.

The absolute speed can be read out via the AZL2.

No.	Parameter
935	Absolute speed

The current speed in standardized form can be read out via the AZL2.

No.	Parameter
936	Standardized speed

Speed input X74 pin 4

Motor speed:	300...14000 rpm
100% speed:	650...14000 rpm
Sensor:	Inductive sensor to DIN 19234 (Namur) or Open Collector (pnp) at $U_{CEsat} < 4\text{ V}$, $U_{CEmin} > DC\ 15\text{ V}$
Power supply:	DC 10 V, max. 15 mA
Switching current:	>10 mA
Cable length:	Max. 3 m (sensor cable must be laid separately!)

Sensor disk

Sensor disk and speed sensor can be ordered as accessory set AGG5.310.

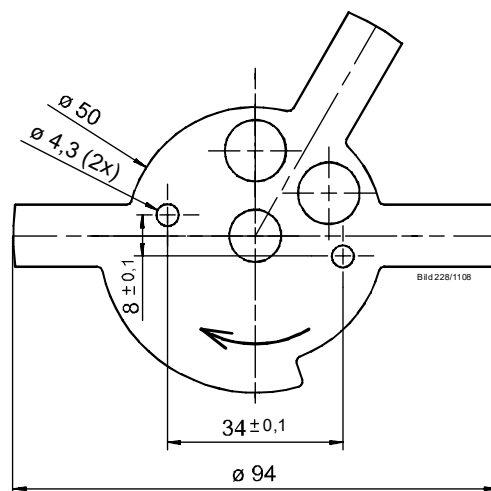

Number of tappets: 3
Angular steps: 60°, 120°, 180°
Accuracy: ±2°

Figure 84: Sensor disk

Speed sensor

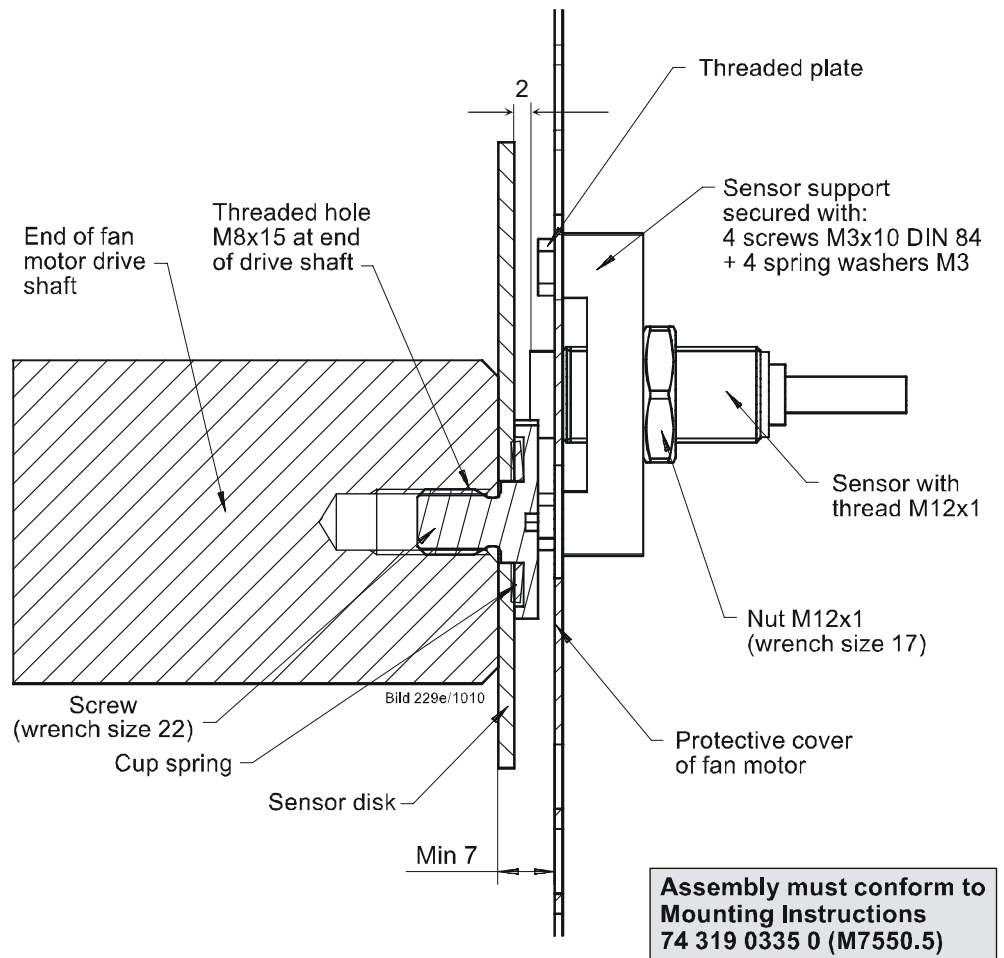

Figure 85: Speed sensor

Selection of fan motor

Motor supplier:

Selection of a motor **with** threaded hole M8 x 15 at the end of the fan motor's drive shaft.

Standard motor and machining (drilling hole and cutting thread M8 x 15).

12.7.2 Acquisition of speed with Hall generator

If the speed is acquired via a Hall generator, the requirements for safety-related applications are the same as those for the speed feedback signal via sensor disk. Required is an asymmetric signal with the 3 pulses of 60°, 120° and 180° for detection of the direction of rotation.

With the PWM fan, the symmetrical hall signal of the fan can also be used for the acquisition of motor speed. The symmetry and the number of pulses must be adapted for this. The maximum speed is 14000 rpm.

No.	Parameter
643	Setting speed signal 0 = asymmetrical 1 = symmetrical
644	Number of pulses per rotation (1 to 6)

12.7.3 Forced travel fan

When a symmetrical speed signal is used, like with the actuators, a forced travel is also carried out for the fan to detect an error in the speed feedback signal when a speed is maintained for a long period of time. The activation of the forced travel is started if the fan has not moved by more than the neutral zone of the speed supervision (parameter 662) for longer than 50 minutes. During the forced travel, the fan travels 1.8% (parameter 531) toward the lower speed and back to the original speed. If the start speed is lower than 10% plus the value of parameter 531, the fan speed is increased to prevent a drop below the minimum speed specification. All relevant actuators are always moved during the forced travel. This means that, when the forced travel is actuated due to insufficient change in speed, the active actuators are also subjected to a forced travel or vice versa. This procedure reduces the frequency of the forced travel of the LMV37.4, as all actuators are processed synchronously.



Note

Duration of forced travel!

The total forced travel duration is dependent on the longer of the two ramp times (parameter 522 or parameter 523) and the change in speed (parameter 531).

The forced travel duration is made up of ...:

1. the travel time to the new position
2. the time it takes (max. 2.6 seconds) for a change in speed of at least 0.3% to occur
3. the travel time to the original position

Example:

Parameter 522 = 5 s + parameter 531 = 1.8% corresponds to min. 0.2 s / max. 2.8 s

Parameter 522 = 40 s + parameter 531 = 4% corresponds to min. 3.2 s / max. 5.8 s

No.	Parameter
522	Ramp up
531	Speed change of forced travel
662	Neutral zone of the speed supervision

12.8 Speed control

The LMV37.4 controls the fan motor's speed to the setpoint. To ensure that the speed can still be increased when the maximum speed is reached, the speed is standardized when the motor is controlled at 95%. Hence, with a speed setpoint of 100 %, a speed increase of 5 % is still possible. The control range of the LMV37.4 is +15% / -10%. If this range is not sufficient, error 80 or 83 can occur.

Error code	Diagnostic code	Meaning for the LMV37.4
80	1	Control range limitation at the bottom
	2	Control range limitation at the top



Note

Internal control with a VSD or PWM fan motor must not be activated. Otherwise, speed variations can occur, resulting from simultaneous control actions from both the LMV37.4 and internal control.

The internal control of the LMV37.4 can be deactivated via parameters. On the one hand, this takes place automatically if a pneumatic operating mode is selected (see chapter *Selection of operating mode*). This is also necessary when a self-regulated PWM fan is used in an electronic fuel-air ratio control system. The speed control setting also has an impact on the determination of the standardized speed (see chapter *Speed standardization*).

No.	Parameter
661	LMV37.4 internal speed control 0 = deactivated (self-regulated PWM fan) 1 = activated (VSD)

12.9 Speed supervision

The fan's current speed is acquired by the LMV37.4 and assessed from a safety point of view. If the fan does not operate at the speed setpoint, speed control makes a corrective action, trying to reach the setpoint. If it is not reached within a certain period of time, safety shutdown is initiated. To ensure a high level of availability and safety, a number of monitoring bands with different response times are defined.

To adapt to the application, the tolerance bands and response or shutdown times can be changed via the OEM level in defined limits:

Tolerance band	Adjustable value range	Adjustment of the shutdown time
0...Neutral zone	Neutral zone (0.5...3.5%)	∞
Neutral zone...Close range	Close range (2...5.5%)	<8...16 s
> close range		<3...7 s

The combination of tolerance band and shutdown time must be chosen by the OEM so that no hazard potential can occur within the application.

No.	Parameter
662	Neutral zone of the speed supervision
663	Close range of the speed supervision
664	Speed supervision: Maximum time between the neutral zone and close range
665	Speed supervision: Maximum time outside close range

It is possible to switch off speed supervision at standstill (no-load speed 0%) in standby mode. This may be necessary if the fan rotates too much in standby mode due to a chimney draft or if an extended ramp time is active with a PWM fan during the transition from the postpurge speed to standstill.

No.	Parameter
653	VSD standstill supervision in standby mode 0 = deactivate 1 = active

The following tolerance bands and shutdown times apply in the default setting:

Speed deviation in % points	Shutdown time
0...0.5%	Speed reached → no shutdown
0.6...2%	<8 s
2.1...10%	<3 s
>10%	<1 s

12.9.1 Extended speed supervision

Additional supervision limits can be activated via the OEM level for different operating states. A check is only carried out to determine whether the value was exceeded or fallen short of here. A shutdown takes place after the *Maximum time outside close range* (parameter 665, default setting 3 s) has elapsed. An interruption in the speed feedback signal results in a safety shutdown within 1 second.

These limits can also be activated in pneumatic operation if a speed signal is present.

No.	Parameter
226	Gas: Preignition time
266	Oil: Preignition time
665	Speed supervision: Maximum time outside close range
667	Minimum prepurge speed
668	Maximum ignition speed
669.0	Minimum / maximum speed limitation in operation Index 0 = minimum speed
669.1	Minimum / maximum speed limitation in operation Index 1 = maximum speed

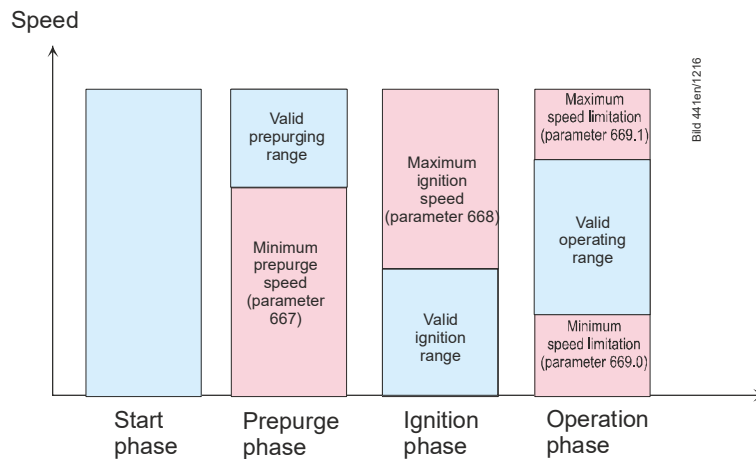

Figure 86: Extended speed supervision



Note!

- The standardization in pneumatic operation is only possible if at least one extended speed supervision has been activated (parameter 667, 668 or 669.0 / 669.1). The supervisory functions are deactivated in the presetting
- When supervising the maximum ignition speed, the preignition time (parameter 226 / 326 or 266 / 366) must correspond to at least the time setting *Maximum time outside close range* (parameter 665)

Error code	Diagnostic code	Meaning for the LMV37.4
83	Bit 0 Valency 1	Lower control range limitation
	Bit 1 Valency 2...3	Upper control range limitation
	Bit 2 Valency 4...7	Interrupt shutdown due to electromagnetic interference
	Bit 3 Valency ≥ 8	Curve too steep in terms of ramp speed
	Bit 4 Valency ≥ 16	Interruption of speed signal
	Bit 5 Valency ≥ 32	Quick shutdown due to excessive speed deviation
	Bit 6 Valency ≥ 64	Minimum speed fall below
	Bit 7 Valency ≥ 128	Maximum speed exceeded
	192	Incorrect setting: Minimum speed \geq maximum speed Incorrect setting: Neutral zone \geq close range
	255	Error forced travel PWM fan

12.10 Setting the parameters of VSD

If a control signal of 95% (9.5 V) is not sufficient for the burner to deliver its rated capacity, you can proceed as follows:

- Set the maximum frequency to 105.3% of the motor's rated speed

In the case of a motor frequency of 50 Hz, this means:

Set the maximum frequency of the VSD to $50 \text{ Hz} \times 1.053 = 52.6 \text{ Hz}$ (on the VSD).

- Then, standardize the speed (refer to chapter *Standardization of speed*)

There is no risk of motor overload since only 95% of the maximum control signal is delivered during standardization and – later in operation – the effective speed is controlled and monitored.

Frequencies of between 50 Hz and 52.6 Hz are delivered only if these are needed for reaching the required speed due to increased output.

- Set the ramp times of the VSD according to chapter *Setting the ramp times*

12.11 Standardization of speed

Since the different types of fans operate at different speeds and signal handling should be as straightforward as possible, all speeds in the LMV37.4 are standardized between 0% and 100%. For this reason, the VSD module uses a parameter which contains the *Standard speed* (100% speed). All absolute speeds refer to this speed.

If changes to the VSD or the fan are made, speed standardization should be repeated.



Caution!

- **If automatic speed standardization is activated, or if the standardized speed is changed, the settings of fuel-air ratio control must be checked! Any change of the standardized speed alters the assignment between the percentage values parameterized on the curves and the speed**
- **When the parameter set (refer to ACS410 (J7352)) is restored, the standardized speed is restored also. If a data set is transferred to a new LMV37.4 via the restore process (e.g. during a device replacement), the standardization of the speed must be carried out again**
- **In pneumatic fuel-air ratio control, at least one additional supervision threshold (parameter 667, 668 or 669) must be activated to carry out a speed standardization**

No.	Parameter
667	Minimum prepurge speed
668	Maximum ignition speed
669	Minimum / maximum speed limitation in operation Index 0 = minimum speed Index 1 = maximum speed

Automatic speed standardization

To facilitate determination of the standardized speed, the LMV37.4 features automatic speed standardization. The speed must be standardized while in standby mode. Speed standardization is integrated in the setting process for electronic fuel-air ratio control, but can also be started later from the parameter setting level. When using a release contact for the VSD (external relay at fan output X3-05 pin 1), the fan output is controlled during speed standardization.

1. Start speed standardization

To start automatic speed standardization, set parameter 641 to 1.

No.	Parameter
641	Control of VSD's speed standardization Error diagnostics of negative values (refer to error 82) 0 = no speed standardization 1 = speed standardization active

2. Drive the air damper to the prepurge position

Speed standardization begins when the air damper travels to the prepurge position. When this position is reached, the air damper should be fully open so that the fan operates at full capacity.

3. Control the VSD

The VSD is activated with 95% of the maximum voltage during active speed control. A margin of 5% allows the speed to be readjusted should environmental conditions change. This means that full speed (100%) is reached with 95% VSD control (refer to chapter *Setting the parameters of the VSD*).

The specification for determining the standardized speed varies depending on the speed control setting and the selected operating mode. This means that a slightly reduced fan speed may be available.

Internal control parameter 661	Electronic fuel-air ratio control (e.g. operating mode 1: <i>G mod</i>)	Pneumatic fuel-air ratio control (e.g. operating mode 7: <i>G mod pneu</i>)
1	95% regulated operation	100% pneumatic
0	98% unregulated operation	98% pneumatic (deactivated control has higher priority than pneumatic fuel-air ratio control)

No.	Parameter
661	LMV37.4 internal speed control 0 = deactivated (self-regulated PWM fan) 1 = activated (VSD)

4. Wait until the speed is higher and has stabilized

Before the 100% speed can be measured, the fan must have reached stationary conditions. This means that the fan must operate under stable conditions above 650 rpm. When this state is reached, a certain waiting time is observed, allowing the speed to eventually stabilize.

5. Measure the speed and store it

When the speed has stabilized, measure and store it as the *Standardized speed* (100% speed).

6. Close the standardization

When standardization is successfully completed, reset parameter 641 to **0**.

If standardization was not successful, parameter 641 assumes a negative value.

No.	Parameter
641	Control of VSD's speed standardization Error diagnostics of negative values (refer to error 82) 0 = no speed standardization 1 = speed standardization active

The value provides information on the cause of fault:

Value	Error	Remedy
-1	<i>Timeout of standardization (VSD's ramp down time too long)</i>	Timeout at the end of standardization during ramp down of VSD. → VSD ramp time settings are not shorter than those of the LMV37.4 (parameter 523).
-2	<i>Storage of standardized speed not successful</i>	Error during storage of standardized speed → lock the LMV37.4 and reset it again, repeat standardization
-3	<i>Line interruption speed sensor</i>	LMV37.4 receives no pulses from the speed sensor. 1. Motor does not run. 2. Speed sensor is not connected. 3. Speed sensor is not actuated by the sensor disk (check distance).
-4	<i>Speed variation / VSD ramp up time too long / speed below minimum limit for standardization</i>	Motor has not reached a stable speed after ramp up. 1. VSD ramp time settings are not shorter than those of the LMV37.4 (parameters 522, 523). 2. VSD's characteristic is not linear. Configuration of voltage input at the VSD must accord with the configuration of the LMV37.4 (DC 0...10 V). 3. VSD does not follow quickly enough the change of the LMV37.4. Check VSD settings (input filter, slippage compensation, hiding various speeds). 4. Speed of VSD lies below the minimum for standardization (650 rpm).
-5	<i>Wrong direction of rotation</i>	Motor's direction of rotation is wrong. 1. Motor turns in the wrong direction → change parameterization of the direction of rotation or inter change 2 live conductors. 2. Sensor disk is fitted the wrong way → turn sensor disk.
-6	<i>Unplausible sensor signals</i>	The required pulse pattern (60°, 120°, 180°) has not been correctly identified. 1. Speed sensor does not detect all tappets of the sensor disk → check the distance. 2. As the motor turns, other metal parts are detected also, in addition to the tappets → improve mounting. 3. Electromagnetic interference on the sensor lines → check cable routing, improve EMC.

Value	Error	Remedy
-7	<i>Invalid standardized speed</i>	Standardized speed measured does not lie in the permissible range → Motor turns too slowly or too fast
-15	<i>Speed deviation $\mu C1 + \mu C2$</i>	The speeds between $\mu C1$ and $\mu C2$ deviated too much. This can be caused by wrong standardized speeds (e.g. after restoring a data set to a new LMV37.4) → repeat standardization and check the fuel-air ratio
-20	<i>Wrong phase of phase manager</i>	Standardization was made in a wrong phase → permitted are only phases ≤ 12 → load controller OFF, start standardization again
-21	<i>Safety loop / burner flange open</i>	Safety loop or burner flange is open → repeat standardization with safety loop closed
-22	<i>Air actuator not referenced</i>	Air actuator is not referenced or has lost its reference. 1. Check if the reference position can be approached. 2. Check if actuators have been mixed up. 3. If error only occurs after standardization was started, the actuator is possibly overloaded and cannot reach the required position.
-23	<i>VSD deactivated</i>	Standardization was started with VSD deactivated → activate VSD and repeat standardization
-24	<i>No valid operating mode</i>	Standardization was started with no valid operating mode → select a valid operating mode and repeat standardization
-25	<i>Pneumatic fuel-air ratio control</i>	Standardization was started with pneumatic fuel-air ratio control → standardization with pneumatic fuel-air ratio control is not possible

The result of speed standardization (100% speed) can be read out via parameter. The speeds acquired by the 2 microcontrollers can differ by about 1.5%, the reason being slightly different resonator frequencies.

No.	Parameter
522	Ramp up
523	Ramp down
642.0	Standardized speed Index 0 = speed 1
642.1	Standardized speed Index 1= speed 2 (internal monitoring)
642.2	Fuel 1: Standardized speed Index 2 = speed 3
642.3	Fuel 1: Standardized speed Index 3 = speed 4 (internal monitoring)
645	Configuration of analog output 0 = DC 0...10 V 1 = DC 2...10 V 2 = DC 0/2...10 V



Note!

Different standardized speeds for fuel 0 and 1 in dual fuel operation are only necessary if the internal speed control of the LMV37.4 is active and the LMV37.4 is operated in mixed operation *electronic fuel-air ratio control / pneumatic fuel-air ratio control*.

12.12 Control of fan motor with pneumatic fuel-air ratio control

For the fan motor control for burners with pneumatic fuel-air ratio control, only the control path is used with the factory setting
There is no need to connect a speed feedback signal and to have speed control (for operating modes, refer to chapter *Selection of operating mode*).

If speed monitoring is required in the pneumatic ratio control, additional supervision thresholds can be activated (see chapter *Acquisition of speed* or *Extended speed supervision*).

12.13 EMC of LMV37.4 and VSD

The function and EMC tests with the LMV37.4 have been successfully conducted in connection with the following makes and types of VSDs:

Siemens: SED2-0.37 / 22 X
Danfoss: VT2807

During operation, VSDs generate electromagnetic interference on the mains network. For this reason, the supplier's specifications must be strictly observed to ensure that makeup of the system is in compliance with EMC regulations:

Siemens: Operating Instructions → installation conforming to EMC
Danfoss: Technical Brochure → radio suppression filter
Data Sheet on Danfoss EMC filter for long motor cables



Caution!

When using other types of VSD, compliance with EMC regulations and trouble-free operation are not ensured!

12.14 Special conditions for PWM fan in electronic fuel-air ratio control system

When using a PWM fan in the electronic fuel-air ratio control system, different conditions must be observed or complied with.

This is connected, among other things, with the different properties of the PWM fan compared with VSDs.

- Fan characteristic
- Load dependency of the speed
- Reduced braking performance
- Acquisition of speed

12.14.1 Characteristics PWM fan

The LMV37.4 works with a standardized speed signal, with linear interpolation between standstill and the standardized speed (nominal speed). The requirement for this assumption is a linear fan characteristic, which is achieved solely by self-regulated PWM fans.

To prevent conflicts between self-regulated fans and the internal speed control of the LMV37.4, it must be deactivated (parameter 661; see chapter *Speed control*). The tolerance limits may also have to be adapted to the speed supervision (see chapter *Speed supervision*).

In contrast to a VSD, the fan speed of a PWM fan is heavily dependent on the load (air throughput) of the fan. This characteristic is partially balanced out by a self-regulated PWM fan, but still leads to a big time difference in the comparison between acceleration and deceleration. The extreme case here is a closed air damper, e.g. during the transition from postpurging to standby.

Another disadvantage of the current PWM fan is the partially significantly reduced braking performance (without the option of additional braking resistances, e.g. with a VSD). This means that the different ramp time values for run-up / run-down (parameter 522 / 523) have to be set. This behavior must also be taken into account with the modulating operating ramp (parameter 544).

The LMV37.4 also has the option of activating the actuators with a time delay (parameter 529). In this case, the braking performance is improved by carrying out the speed reduction with the air damper open. The air throughput increases the braking performance of the fan, which reduces the speed faster. This process can be set during the transition from prepurging to ignition (phase 35), when moving in postpurging (phase 71) and from postpurging to standby (phase 79). The air actuator is only moved to the relevant damper position once the ignition speed or standby speed is achieved.

If value 2 is set, an additional tolerance increase of 50% on the neutral zone (parameter 662) and the close range (parameter 663) of the speed supervision is possible outside of operation.

No.	Parameter
522	Ramp up
523	Ramp down
529	Separate movement of the fan (ignition speed / postpurge speed) 0 = deactivated 1 = activated 2 = activated (50% tolerance increase outside operation)
544	Ramp modulating
661	LMV37.4 internal speed control 0 = deactivated (self-regulated PWM fan) 1 = activated (VSD)
662	Neutral zone of the speed supervision
663	Close range of the speed supervision

12.14.2 Acquisition of speed PWM fan

Due to design-related restrictions, it is usually not possible to mount a sensor disk for generating an independent, asymmetrical (direction of rotation sensitive) speed signal on a PWM fan. Instead, the symmetrical speed signal of the PWM fan based on the Hall effect is used. No direction of rotation recording is possible due to the symmetrical structure.

The PWM function in the electronic fuel-air ratio control system is only permitted in conjunction with a fail-safe feedback signal of the fan with error analysis (in accordance with EN 60730-1:2016 class C).

For a plausibility check with regard to a fault-free Hall feedback, an additional speed-dependent air pressure switch can therefore be used for a comparison between the speed signal and the resulting air pressure (see chapter *Additional speed-dependent air pressure switch*).

With a correspondingly high ON threshold of the air pressure switch, this also includes verification of the correct direction of rotation and the required air quantity for prepurging and high-fire.

The system manufacturer / system operator must determine and guarantee that adequate fail-safe properties are achieved in accordance with standards.

The LMV37.4 fulfills the requirement of the UL standard, EN 12067-2 and ISO 23552-1 (fuel-air ratio control) if the following basic principles are met:

- Directly connected PWM fan
- Directly fail-safe feedback signal of the fan according to EN 60730-1:2016 class C

If the basic principles outlined above are not met, the local safety regulations for the application must be checked by the system manufacturer / system operator.

The safety of the entire LMV37.4 must be guaranteed by the system manufacturer / system operator.



Attention!

To avoid personal injury or damage to property, the following note must be observed.

If the feedback signal of the fan does not correspond to EN 60730-1:2016 class C, there is a risk of unclean combustion, which can lead to the following:

- CO emissions and poisoning
- Explosion
- Damage to property

12.15 Trim function

The trim function enables the specified speed of the fuel-air ratio control curve to be changed in adjustable limits via 4...20 mA input. The residual oxygen content of the flue gas or the supply air temperature can be used for determining the current setting. Depending on the setting, the trimming can be activated from ignition or only in operation, between low-fire and high-fire, after an adjustable wait time has elapsed. No trimming of the fan speed takes place during the curve setting.

The restriction of the trimming range must be selected so that no unsafe state can occur in the application under any environmental conditions. The LMV37.4 also has various options for ensuring that the trim function or the components involved in the trim function run correctly (see chapter *Optional internal checks* / chapter *Optional external checks*).



Invalid output specification during trim function with LMV37.420A1

Note!

The LMV37.4 does not have any OPEN / CLOSED load controller inputs if the switching back to pilot function (parameter 191) is activated.

When the trim function is activated, the output specification via the analog input also no longer applies, which, in this case, only leaves the specification from the building automation via Modbus as the lowest priority load controller source.

To protect the LMV37.4 from an invalid output specification (error code **C: 60**) in this constellation after switching on or after a fuel change, a valid Modbus standard output must be defined if the building automation is interrupted (Modbus parameter 148; presetting is invalid).

No.	Parameter
148	<p>Predefined output in the event of communication breakdown with building automation</p> <p>Setting values: For modulating operation, the setting range is as follows: 0...19.9 = burner off 20...100 = 20...100% burner output (20 = low-fire position)</p> <p>For multistage operation, use the following settings: 0 = burner OFF P1...P3 = stage 1...stage 3</p> <p>Invalid = no output predefined by the building automation system in the event of communication breakdown</p> <p>Default setting: <i>Invalid</i></p>



Note!

A detailed description of parameters 148 and 149 can be found in the chapter *Output specification via building automation*.

12.15.1 Settings and mode of operation

The maximum trimming range of -15...+25% cannot be changed and is intrinsically linked to the 4...20 mA specification of the analogue input (40% trimming range based on 16 mA → 1% trim per 0.4 mA).

- 20 mA = +25% speed correction
- 10 mA = 0% or no speed correction
- 4 mA = -15% speed correction

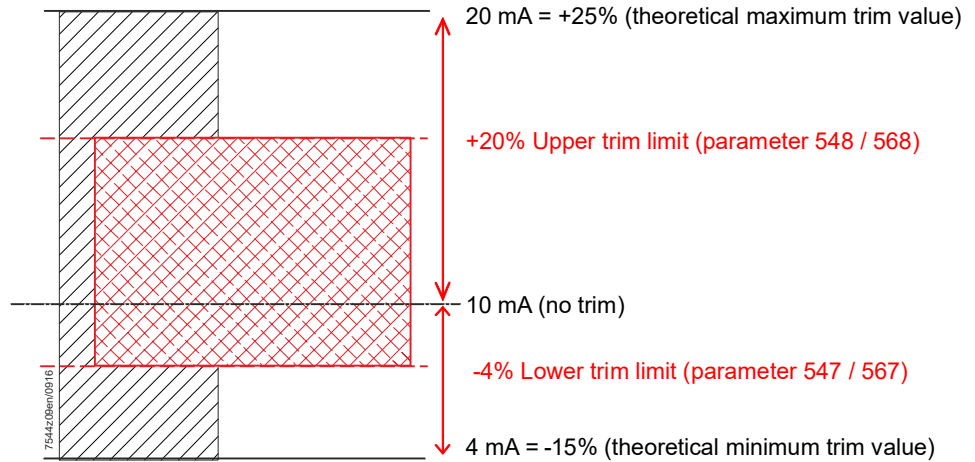

Figure 87: Setting range trim limits

In order to adapt to the application and the environmental conditions present at the time the settings are made, the trim range can be restricted independently for each fuel (the setting 0% deactivates the relevant direction of influence). It is also possible to set a wait time (parameter 550) for trim function activation, e.g., to obtain reliable residual oxygen content values for O₂ trimming. The wait time during operation can be practically deactivated by selecting an extremely low value if the trim function is used as temperature compensation. To respond to altered environmental conditions in the ignition and to improve the ignition behavior, the ignition speed can also be adapted depending on the ambient temperature where necessary. The temperature-dependent offset on the ignition speed specified in the prepurging is retained until the delay time has elapsed in operation.

No.	Parameter
550	Fuel 1: Trim delay time (after entering phase 60)

Impact of the trimming with different outputs

It is unlikely that an identical trim correction (e.g. +10% speed) will have the same impacts for low-fire and high-fire. This is why load-dependent trim damping is used. The damping factor is based on low-fire and can be set in the value range 0% (no damping) to 100% (no trimming with low-fire). The damping is interpolated linearly to the low-fire based on the current (limited) trim correction value. The output-dependent impact of the trim correction can already be taken into account by the external control in the current setting.



Note!

The impact of the trimming is changed very slowly with 0.1% per 0.2 seconds. This means that it takes 50 seconds to deactivate the trim function starting from +25%.

No.	Parameter
204	Behavior if analog input is invalid (4...20 mA) 0 = deactivate default output low-fire / trim function (with warning message) 1 = safety shutdown + startup prevention 2 = deactivate default output low-fire / trim function (without warning message)
530	Activation trim function 0 = inactive 1 = active 2 = active (including test function for analog input) 3 = active (including ignition speed) 4 = active (including ignition speed and analog input test)
547	Lower range limit trim function
548	Upper range limit trim function
549	Damping factor for trim function (based on low-fire)
550	Delay time / wait time for trim function after entering phase 60
551	Wait time until response with active trim limitation
552	Behavior if maximum trim limitation time is exceeded 0 = warning message only (trim impact remains active) 1 = warning and deactivation of the trim function 2 = shutdown

12.15.2 Optional internal checks

The LMV37.4 has various settings and monitoring options to ensure that the trim function runs correctly and error-free. The external control unit and control section are used here in places. The OEM is responsible for implementing the necessary measures for fulfilling the local requirements.

Plausibility check for the curve setting

When the trim function is activated, the LMV37.4 carries out permanent supervision of the speed curve. In order to cover the desired range with the trim function, a sufficient reserve must be available in the curve setting (e.g. upper trim limit 10% → 90% maximum curve setting). Otherwise, it wouldn't be possible to carry out the desired trim correction, as the speed would be limited by the minimum or maximum limitation.

Error-code	Diagnostic code	Meaning for the LMV37.4
155	#	Trim function: Invalid curve setting VSD / PWM fan
	0..9	Minimum value VSD curve fall below
	20..29	Maximum value VSD curve exceeded
	40..49	Fuel 1: Minimum value VSD curve fall below
	60..69	Fuel 1: Maximum value VSD curve exceeded

Plausibility check for range limitation

A plausibility check can be activated to show if the LMV37.4 remains on a range limit of the trim function for a defined time (time setting = 0 deactivates the check / warning / shutdown).

This can be used to identify an incorrect setting in the trim function.

In the default setting, no shutdown takes place and only a warning is generated.

This means that the LMV37.4 remains in operation.

Deactivation of the trim function and a shutdown can also be triggered in response to the system remaining on a range limit for too long.

If error code **C:156** is only output as a warning message, it can only be seen for the period the error is active, as warning messages are not saved permanently in the error history.

The PLC must therefore read out the current error memory of the LMV37.4 cyclically via Modbus (e.g. every 2...30 s) and save a corresponding warning message permanently.

Error-code	Diagnostic code	Meaning for the LMV37.4
156	#	Trim function: Maximum time for range limit exceeded
	0	Trim function at lower limit
	1	Trim function at upper limit
	10	Fuel 1: Trim function at lower limit
	11	Fuel 1: Trim function at upper limit

Analogue input test during burner startup

A test sequence with 2 current thresholds can be used to identify errors in the analog input during burner startup.

To this end, the PLC must deliver a current of 10 mA (0%) during standby and a current of 4 mA (-15%) during *traveling to prepurging* or the first 2 seconds in *prepurging*.

The LMV37.4 uses these test values to check for fault-free function of the analog value recording and can therefore detect component faults and drift.

The expected values are also used for indirect supervision of the Modbus communication and the external control (PLC).

In the event of an error, the burner startup is prevented (test in standby) or canceled (test in prepurging).

The test can only be carried out during burner startup, a cyclical test during operation is not possible.

For this reason, the forced intermittent operation may not be switched off when the analog input test is activated.

This ensures that the analog input test is carried out at least once every 24 hours.

The supervision is carried out by LMV37.4.

The PLC or the external control can read out the LMV37.4 phase information required for the test via Modbus.

Error-code	Diagnostic code	Meaning for the LMV37.4
157	#	Trim function: Analog input test
	0	Analog value standby
	1	Analog value prepurging

12.15.3 External tests (optional)

In addition to the LMV37.4 internal tests, various states may also be monitored by an external PLC or control. Selected process parameters, e.g. the current phase, can be read out via Modbus for this purpose. In this case, the LMV37.4 is shut down via a self-locking NC contact of the PLC in the safety loop (X3-04 pin 1 and pin 2) or in series with the load controller ON signal (X5-03 pin 1 and pin 4).

Impact of the trimming range restriction with PLC

The defined assignment between the current setting and trim impact (4...20 mA is shown as -15...+25 %) must also be taken into account by the PLC. Particularly when reducing the possible trim range (parameter 547 / 548 or 567 / 568), the PLC must also take the reduced limit values into account. The relevant parameters can be read out via Modbus for this purpose.

To guarantee that, despite tolerances between the PLC analog output and LMV37.4 analog input, the maximum limits for the trimming can be achieved, the PLC must deliver a current value that is approx. 0.5% (i.e. approx. 0.2 mA) off the set limit values (over for the upper limit, under for the lower limit).

No.	Parameter
547	Lower range limit trim function
548	Upper range limit trim function

External supervision: Target/actual comparison of the trim specification

The single-channel version of the LMV37.4 analog value recording is not fail-safe. The control unit responsible for the specification of the 4...20 mA signal for O₂ trimming can either trigger a safety shutdown or shutdown via an NC contact if an excessively large deviation is detected between the trim setpoint and the determined trim specification of the LMV37.4. To this end, the trim specification of the LMV37.4 can be read out via Modbus (raw value, target value with limitation and damping, as well as the current active trim influence).

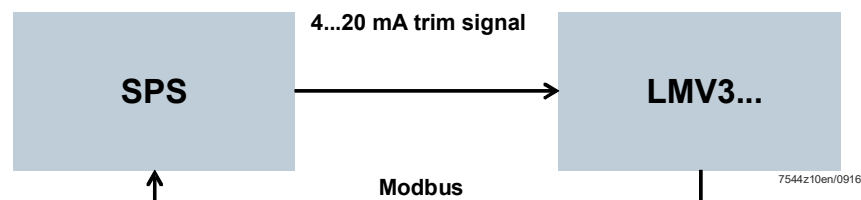

Figure 88: Trim supervision with PLC

With this supervision, the PLC can create a closed loop over the analog input of the LMV37.4 and the trim specification, including the analog output of the PLC, via Modbus.

External supervision of the residual oxygen content in the flue gas

Particularly for a trim specification based on an O₂-measurement, there is the option of additional supervision of the flue gas values with regard to the minimum / maximum O₂ value. For this, the PLC can read out the LMV37.4 phase and LMV37.4 output via Modbus and supervise output-dependent minimum / maximum O₂ values. This ensures that the application is always operated in the correct working range.

In the event of an error, a safety shutdown via the safety loop or a shutdown via the load controller ON signal can be triggered as a response as required. Another option in the event of an error is to deactivate the trim function via a 10 mA current setting in the PLC.

Trim range test via PLC

Once the curve setting or commissioning is complete, a trim range test must be carried out to check the influence on the application.

The test is initiated by the PLC, which provides both the output specification (via Modbus) and the trim specification (via 4...20 mA).

Test sequence:

1. Starting point:
The PLC delivers a stationary output specification
(→ no modulation during the test sequence)
2. Lower trim limit test:
The PLC delivers the minimum current setting (4 mA)
Verification of the flue gas values if minimum trim influence is active
3. Upper trim limit test:
The PLC delivers the maximum current setting (20 mA)
Verification of the flue gas values if maximum trim influence is active

Steps 1...3 must be carried out at least for low-fire and high-fire to guarantee a correct trim setting.

12.16 Description of connection terminals

12.16.1 VSD

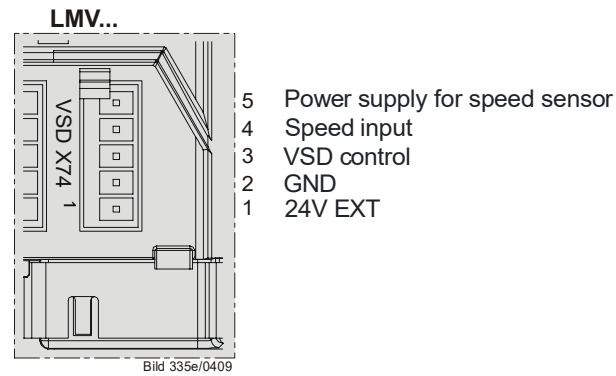

Figure 89: VSD module X74

12.16.2 PWM fan

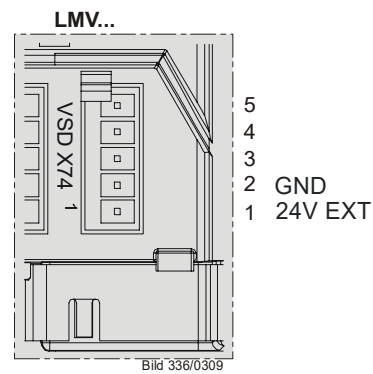

Figure 90: PWM fan X74

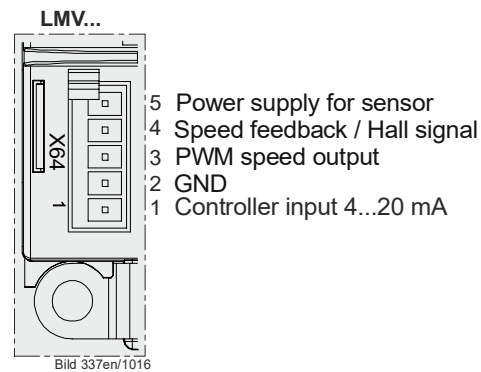

Figure 91: PWM fan X64

13 Load output X74 pin 3

The load output is only available as an alternative to VSD control. If the VSD is deactivated, the output for the VSD delivers the current burner output. The analog output is a voltage output and – using parameter 645 – can be switched between DC 0...10 V, DC 2...10 V and DC 0/2...10 V.

Parameter 645	Voltage range	Remarks
0	DC 0...10 V	No detection of line interruption
1	DC 2...10 V	Detection of line interruption possible
2	DC 0/2...10 V	No detection of line interruption. Recommended setting in connection with Micromaster VSD



Note
 When changing the analog output configuration from DC 0...10 V to DC 2...10 V or DC 0/2...10 V, the voltage values with modulating, 2-stage and 3-stage operation change (refer to chapter *Modulating operation*, chapter *2-stage operation* and chapter *3-stage operation*).

Conversion: New value = (initial value * 0.8) + 2

Example: Initially 2 V → (2 * 0.8) + 2 = 3.6 V
 Initially 5 V → (5 * 0.8) + 2 = 6 V

No.	Parameter
645	Configuration of analog output 0 = DC 0...10 V 1 = DC 2...10 V 2 = DC 0/2...10 V

13.1 Safe separation of mains voltage and extra low-voltage



Caution!
 The load output is designed for SELV or PELV (refer to chapter *Electrical connection of the LMV37.4*).
 For this reason, strict separation from the mains voltage side must be ensured!

This necessitates power supply by an external power pack (X74 pin 1, X74 pin 2).

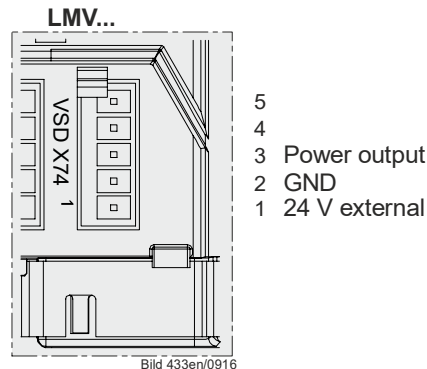

Figure 92: Power output

13.2 Modulating operation

Actual value	Voltage	Curvepoint	Display / output value
Off	DC 0 V	---	Off
Ignition load	DC 1 V	P0	10%
Low-fire	DC 2 V	P1	20%
High-fire	DC 10 V	P9	100%

The values between low-fire and high-fire are interpolated in a linear manner.

13.3 2-stage operation

Actual value	Voltage	Curvepoint	Display / output value
Off	DC 0 V	---	Off
Stage 1	DC 5 V	P1	P1
Stage 2	DC 10 V	P2	P2

13.4 3-stage operation

Actual value	Voltage	Curvepoint	Display / output value
Off	DC 0 V	---	Off
Stage 1	DC 3 V	P1	P1
Stage 2	DC 5 V	P2	P2
Stage 3	DC 10 V	P3	P3

14 Fuel meter input X75 pin 1 / X75 pin 2

A fuel meter can be connected to acquire the amount of fuel burnt. The fuel meter function is only available as an alternative to VSD control. If the VSD is deactivated, a fuel meter can be connected to terminals X75 pin 1 and X75 pin 2.



Figure 93: Fuel meter input X75

14.1 Configuration of fuel meter

14.1.1 Types of fuel meters

The LMV37.4 is designed for use with fuel meters equipped with a Reed contact. Pulse frequency at maximum fuel throughput must be below 300 Hz.

14.1.2 Configuration of pulses per volume unit

Depending on the type of fuel meter used, the number of pulses supplied by it per m^3 or l fuel must be parameterized. A maximum of 400 pulses per volume unit can be preset. The correct amount of fuel is acquired only when this parameter is set.

When the parameter is 0, the fuel meter stops.

No.	Parameter
128	Fuel meter: Pulse valency (pulses / volume unit)

14.1.3 Reading and resetting the meter readings

No.	Parameter
167	Fuel volume resettable (m^3 , l, ft^3 , gal)

The cumulated fuel volume can be read out per parameter. The meter reading can also be reset on the parameter level.

14.2 Fuel throughput

With the fuel meter connected, the LMV37.4 calculates continuously the current fuel throughput. The time required for calculating the fuel throughput varies and lies between 1 and 10 seconds. If the fuel meter delivers no pulses for more than 10 seconds, the display shows **0** fuel throughput. This means that when fuel throughput is at its minimum, the sensor should have a pulse frequency of at least 0.1 Hz. The display is smoothed to improve the settling process. With fuel throughput at its maximum, the maximum frequency is 300 Hz.

14.2.1 Configuration

Calculation of fuel throughput is configured based on the pulse valency of the connected fuel meter.

No.	Parameter
128	Fuel meter: Pulse valency (pulses/volume unit)

When the pulse valency is set to **0.00**, the display shows **0** throughput.

14.2.2 Reading out the fuel throughput

The current fuel throughput can be read out via the following parameter on the service menu:

No.	Parameter
960	Fuel throughput in volume unit /h (m ³ /h, l/h, ft ³ /h, gal/h)

Display of fuel throughput is possible up to 6553 volume units/h.



Note

Display of fuel throughput up to a value of **99.9** on the service menu is made with one decimal place, from **100** with no decimal place.

15 Connection and internal diagram

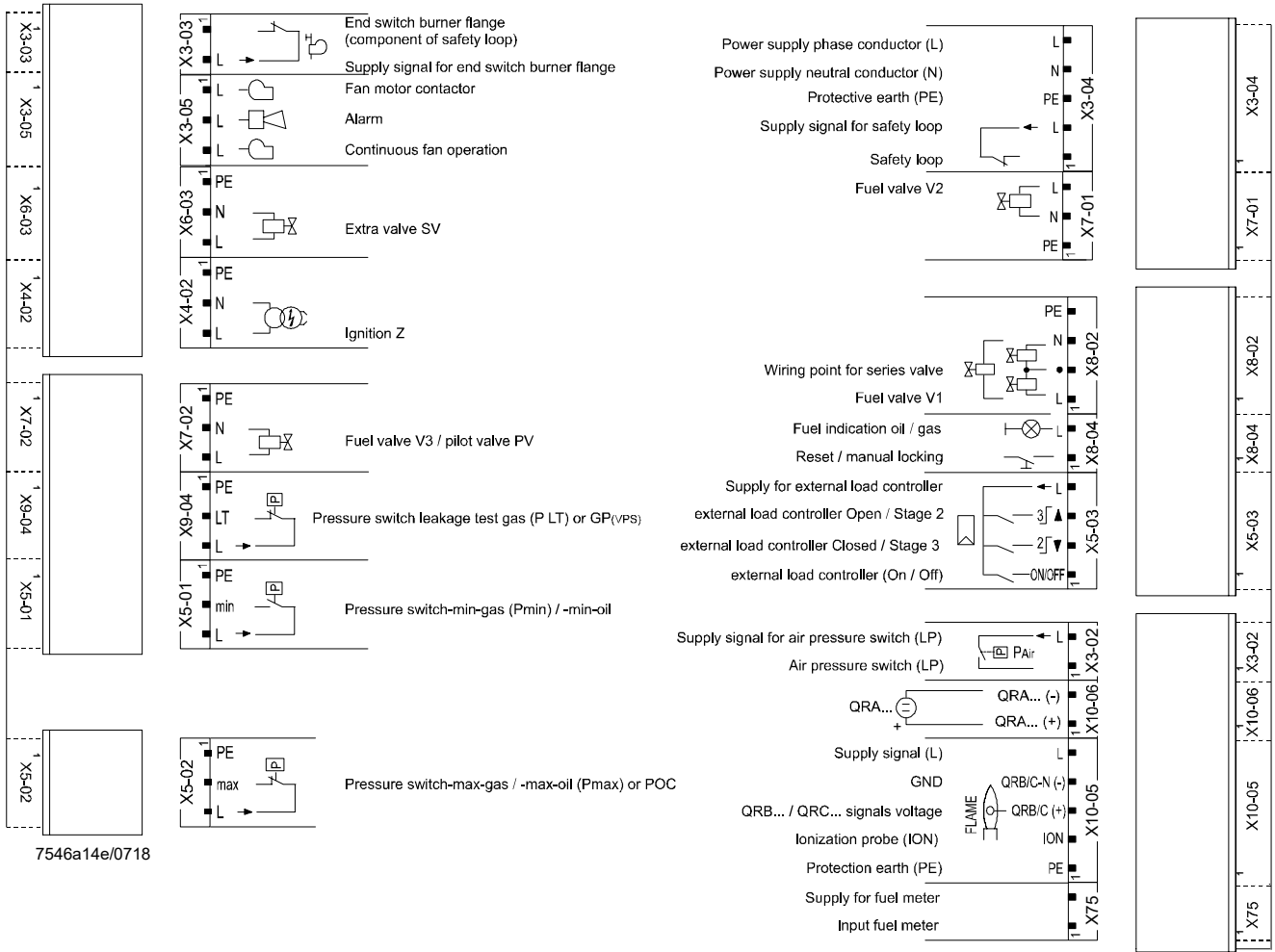

Shielding:

For shielding the cables on the VSD, refer to:

- Siemens *SED2 VSD Commissioning Manual (G5192)*, chapters 4 and 7, or
- Danfoss *Operation Manual VLT 6000 (MG60A703)*, chapter *Installation*

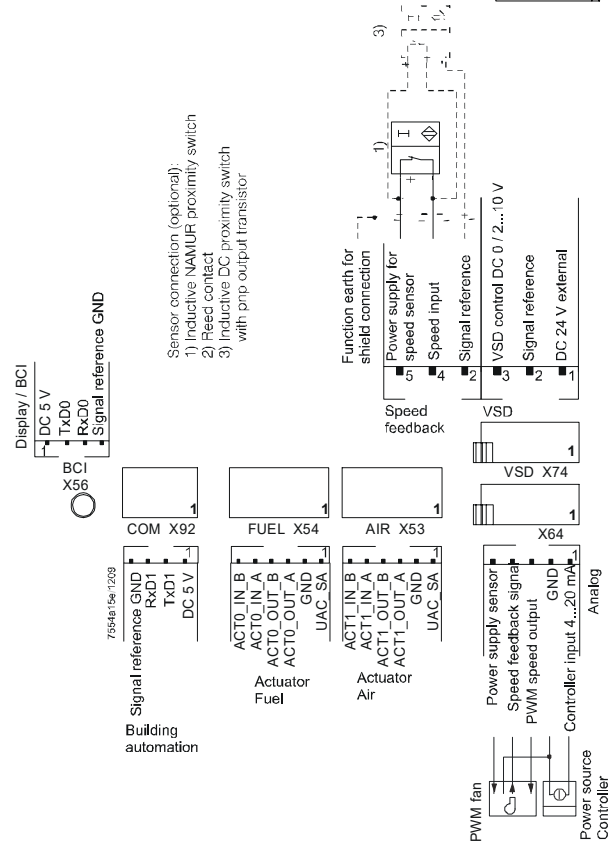

Figure 94: Inputs and outputs

16 Special feature: Burner identification

The OEM must assign an individual burner identification to every burner. This ensures that during backup/restore, incompatible parameter sets cannot be copied between different burners (also refer to the documentation on the PC software ACS410 under *Backup/Restore* and in this documentation in chapter *Backup / Restore*).

No.	Parameter
113	Burner identification

17 Connection to superposed systems

17.1 General information and building automation functions

Communication with a building automation is made possible via a data link using the COM X92 port and a special interface with galvanic separation and physical bus level adaptation. This port can be used for connection of a LMV37.4 with Modbus, depending on the configuration made.

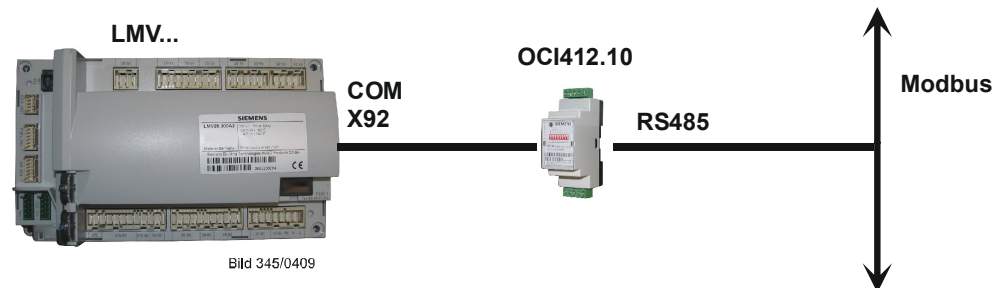

Figure 95: Connection via interface COM 92 to superposed systems



Note

Breakdown of bus communication.

If the LMV37.4 detects a breakdown of bus communication, the building automation system must rewrite the following values upon restoration of communication:

- Modbus: Mode, Modbus operating mode, and predefined target output

General setting values for connection of the LMV37.4 to the building automation system (for factory settings, refer to the parameter list):

Bus communication may only be interrupted for the time set.

If communication is disturbed for a longer period of time, the LMV37.4 delivers a fault status message and the values set in the LMV37.4 by building automation are reset.

No.	Parameter
141	Operating mode building automation 0 = off 1 = Modbus 2 = reserved
142	Setback time in the event of communication breakdown Setting value: 0 = deactivated 1...7200 s
148	Predefined output in the event of communication breakdown with building automation Setting values: For modulating operation , the setting range is as follows: 0...19.9 = burner off 20...100 = 20...100% burner output (20 = low-fire position) For multistage operation , use the following settings: 0 = burner OFF P1...P3 = stage 1...stage 3 Invalid = no output predefined by the building automation system in the event of communication breakdown Default setting: <i>Invalid</i>

The factory settings of the parameters are shown on the parameter list.



Note

For a detailed description of parameter 148, refer to chapter *Default output via building automation*.

17.2 Modbus

With this type of bus protocol, the LMV37.4 operates as a slave on the Modbus and the transmission mode used is RTU (Remote Terminal Unit).
For more detailed information, refer to the Modbus User Documentation (A7541).

No.	Parameter
145	Device address for Modbus of LMV37.4 Setting values 1...247
146	Baud rate for Modbus 0 = 9600 1 = 19200
147	Setting of parity for Modbus communication 0 = none 1 = odd 2 = even

The factory settings of the parameters are shown on the parameter list.



Note

If bus communication breaks down, the mode, Modbus operating mode and predefined target output must be rewritten.

18 PC software ACS410

The ACS410 PC software serves primarily as an operating module for the LMV37.4, providing the following basic functions:

- Visualization of system state via the following data:
 - Parameters
 - Process data
- Configuration and parameterization of the LMV37.4 (individual parameters)
- Backup and recovery of parameter sets



Note
For notes on operation and commissioning, refer to chapter *Operation*.

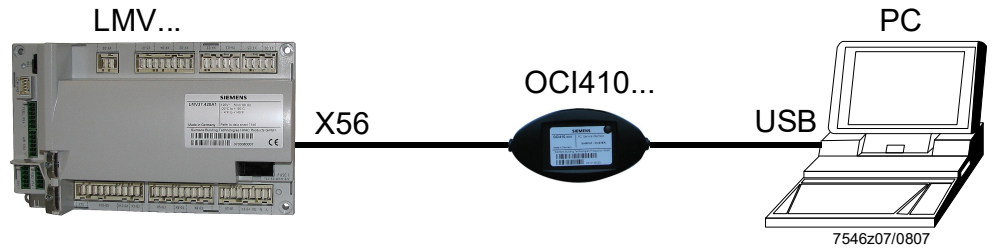

Figure 96: Communication with display / BC interface (RJ11 jack) (X56)

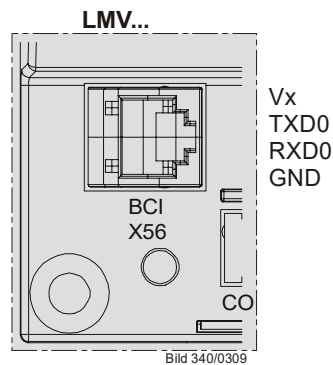

Figure 97: Display input / BC interface (RJ11 jack) X56

If communication between the LMV37.4 and the ACS410 (70 s) has broken down, the password level is reset to *Info / Service*.



Caution!
Interruption of communication between the LMV37.4 and the ACS410 (30 seconds) during the time the curves are set leads to lockout!

Error-code	Diagnostic code	Meaning for the LMV37.4
167	9	Manual locking via PC software ACS410 communication interruption

19 Error history

The LMV37.4 provides an error history in which the last 25 errors are stored. The first entry represents the current error state and can also be «error-free», refer to *Error code list*.

Error code	Diagnostic code	Meaning for the LMV37.4
200 OFF	#	LMV37.4 error-free

19.1 Error classes

The errors are subdivided into error classes, depending on the severity of the switch-off response. The current error shows all classes. Only the errors of the most important classes are included in the history.

Error class	Priority	Meaning	History
0	Highest	Lockout	●
1		Safety shutdown with software reset	●
2		Undervoltage	
3		Safety shutdown: Safety phase	●
4		Safety shutdown: Start prevention	
5		Safety shutdown: Shutdown	●
6	Lowest	Message without shutdown response	

19.2 Makeup of error history

Parameter	Index	Description
701		Current error state, can also be error-free
	.01	Error code (200 = error-free) → refer to <i>Error code list</i>
	.02	Diagnostic code → refer to <i>Error code list</i>
	.03	Error class → error classes
	.04	Phase: Phase in which error occurred → sequence diagrams
	.05	Startup counter: (parameter 166) at which the error occurred
	.06	Output: Burner output at which the error occurred
702	.01..06	Latest error in the history
•		
•		
•		
725	.01..06	Oldest error in the history

No.	Parameter
166	Total number of startups

Deleting the error history

Both the service menu and the parameter setting menu show the error history. The display on the service menu can be deleted in a way that the only errors shown are those that occurred after the deletion. The error history on the parameter setting menu cannot be deleted.

For the deletion, parameter 130 must be set to **1** and then to **2** within 6 seconds. When the parameter returns to **0**, the deletion process is completed.

No.	Parameter
130	Delete display of error history To delete the display: Set parameter to 1 , then to 2 Return value 0: Job successfully completed Return value -1: Timeout of 1 2 sequence

20 Lifecycle function

If the startup counter exceeds a defined threshold, a display error code is set and displayed. The error can be acknowledged. The display code is always set in standby (when there is no heat request). Hence, the moment the threshold is exceeded, the user is notified that the end of the lifecycle of the LMV37.4 will soon be reached.

Error code	Diagnostic code	Meaning for the LMV37.4
116	0	Designed lifecycle exceeded (250,000 startups)



Note
The LMV37.4 should be replaced when this message appears.

21 Safety notes on use of the AZL2

Caution!

To prevent the risk of fire and explosions, damage to heating plant or damage resulting from improper use of the products, ensure that the following safety notes are observed:

The burner management system covered by the present Basic Documentation may only be used as specified and only in connection with the appropriate burner and heating plant.

The burner management system with its AZL2 and the associated heating control system may only be installed and commissioned by authorized technical personnel.



The AZL2 may only be used in dry spaces. Do not use AZL2 outdoors and protect it against excessive temperatures and frost, and liquids, such as water, oil, fuel oil, etc.

Follow exactly the procedures and setting notes given in this Basic Documentation. Appropriately identified settings must only be made by authorized technical personnel.

If the AZL2 is dusty or dirty, clean it with a dry cloth.

Do not carry out any maintenance or repair work on the AZL2. Such work may only be performed by authorized technical personnel.

If you have any questions in connection with the AZL2, please contact your heating engineer or refer to one of the addresses given in this Basic Documentation.

22 Operating via AZL2

22.1 Description of unit/display and buttons

Function and operation of unit versions AZL21 and AZL23 are identical.

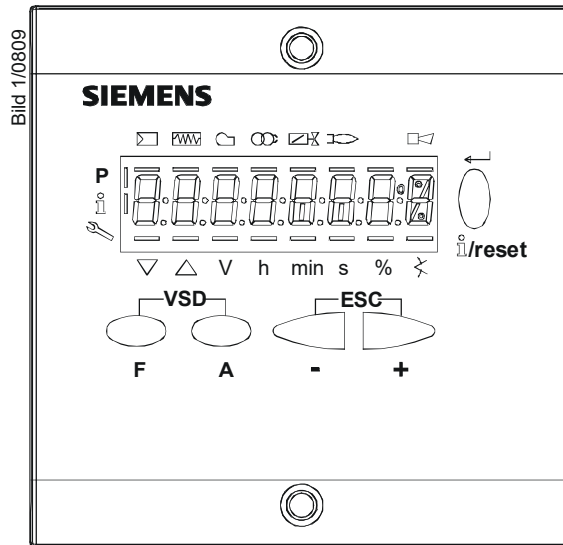







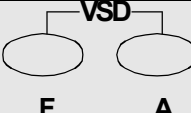







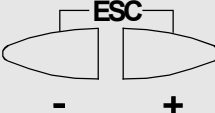



Figure 98: Description of unit/display and buttons

Button	Function
 F	Button F For adjusting the fuel actuator (keep  depressed and adjust the value by pressing  or )
 A	Button A For adjusting the air actuator (keep  depressed and adjust the value by pressing  or )
 F A	Buttons A and F: Parameter function For changing to parameter setting mode P (press simultaneously  and  plus  or )
 i/reset	Info and Enter button <ul style="list-style-type: none"> For navigating in info or service mode <ul style="list-style-type: none"> * Selection (symbol flashing) (press button for <1 s) * For changing to a lower menu level (press button for 1...3 s) * For changing to a higher menu level (press button for 3...8 s) * For changing the operating mode (press button for >8 s) Enter in parameter setting mode Reset in the event of fault One menu level down
 -	- button <ul style="list-style-type: none"> For decreasing the value For navigating during curve adjustments in info or service mode
 +	+ button <ul style="list-style-type: none"> For increasing the value For navigating during curve adjustments in info or service mode
 - +	+ and - button: Escape function (press  and  simultaneously) <ul style="list-style-type: none"> No adoption of value One menu level up

22.2 Meaning of symbols on the display

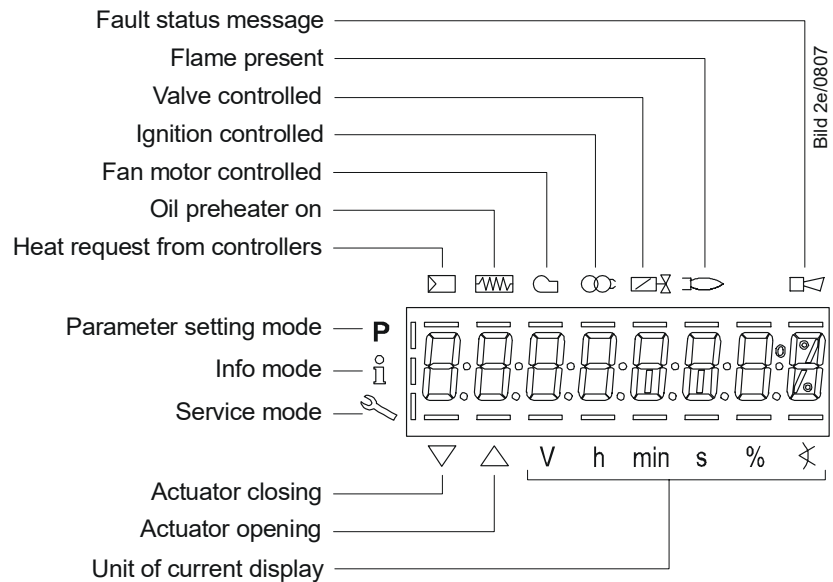

Figure 99: Meaning of display

22.3 Brightness of display

Only available with backlit LCD:

The function of the backlit display is dependent on the type of LMV37.4.

The brightness of the display can be adjusted from 0...100% using parameter 126.

No.	Parameter
126	Display brightness

22.4 Special functions

22.4.1 Manual lockout



/reset
plus other button

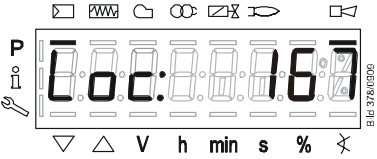

Press  **simultaneously** with any other button.

The LMV37.4 switches instantly to the lockout position, irrespective of the operating position.

The display shows the fault status message.

(Refer to chapter *Error code list!*)

Display: **Loc: 167**

The reset must be carried out as follows:



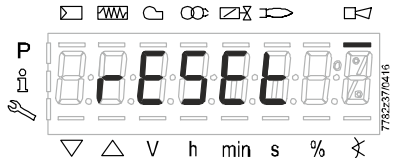

/reset
1 s



When  is pressed for 1 second, **rESEt** appears on the display.

When the button is released, the LMV37.4 is reset.

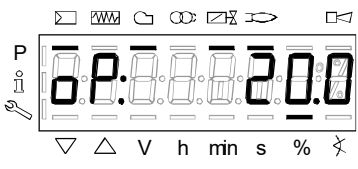
22.4.2 Manual control (manual request for output)

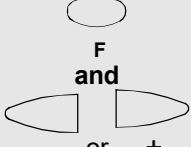
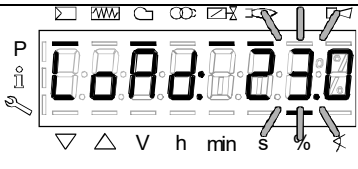
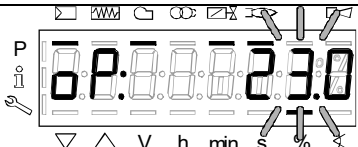
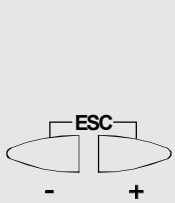
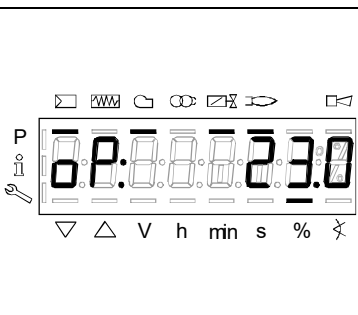
		<p>Burner is in operation.</p> <p>The display shows oP: on the left, the percentage of the current output on the right.</p> <p>Example: oP: 20.0</p>
 <p>F 1 s</p>		<p>Press F for 1 s.</p> <p>The display shows LoAd: the current output flashes.</p>
 <p>F and - or +</p>		<p>Press - or + to adjust the required manual output.</p> <p>Example: oP: 23.0</p>
		<p>Release F.</p> <p>The current manual output flashes, indicating that manual control is activated.</p>
 <p>ESC - +</p>		<p>Press - + for 3 seconds to return to automatic mode.</p> <p>The output no longer flashes.</p> <p>The display shows oP: on the left, the percentage value on the right.</p> <p>Example: oP: 23.0</p>

22.5 Timeout for menu operation

The time for automatically leaving the parameter setting level can be adjusted between 10 and 120 minutes, using the following parameter:

No.	Parameter
127	Timeout for menu operation

If, during that period of time, there is no operation via the AZL2, the parameter setting level is quit and the password level reset to *Info / Service*.



Caution!

In addition, this timeout or interruption of communication between LMV37.4 and the AZL2 during the time the curves are set, leads to lockout!

Error-code	Diagnostic code	Meaning for the LMV37.4
167	8	Manual locking by the AZL2 Timeout / communication breakdown

22.6 Backup / restore

Using the AZL2, the settings made on the LMV37.4 can be stored (backup) and then transferred back to the LMV37.4 at a later point in time.

Creating a backup data set

No.	Parameter
050.0	Index 0: Creation of backup

The following parameters can be used to read information about the backup data set:

No.	Parameter
055	Burner identification of the AZL2 backup data set
056	ASN extraction of the AZL2 backup data set
057	Software version used when creating the AZL2 backup data set

Restoring a backup data set

To transfer a backup data set back to the LMV37.4, the parameter must be set to **1**.

No.	Parameter
050.1	Index 1: Execute restore

22.6.1 Backup

	<p>Parameter 000: flashes.</p> <p>Display: Parameter 000: flashes, Int does not.</p>
	<p>Press + to select parameter 050</p> <p>Display: Parameter 050. flashes, index 00: and value 0 do not.</p>
	<p>Press i/reset to select parameter bAC_UP</p> <p>Display: Parameter bAC_UP</p>
	<p>Press i/reset to select the backup process.</p> <p>Display: Value 0</p>
	<p>Press + to shift the value in change mode 1 position to the left.</p> <p>Display: Value 1 flashes</p> <p>Note To detect potential display errors, the value is displayed 1 place shifted to the left.</p>
	<p>Press i/reset to activate the backup process.</p> <p>Display: 1 appears</p>

Approx. 5 s

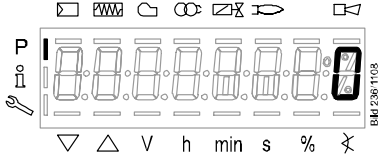

After about 5 seconds (depending on the duration of the program), **0** appears on the display, indicating the end of the backup process.

Display: **0**



Note

If an error occurs during the backup process, a negative value is displayed. For error diagnostics, the cause of the error can be determined from the diagnostic code of error message 137 (see *Error code list*).





Caution!

We recommend to make a backup whenever a parameter is changed!

22.6.2 Restore

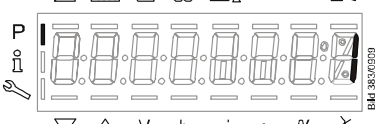
	<p>Parameter 000: flashes.</p> <p>Display: Parameter 000: flashes, Int does not.</p>
	<p>Press + to select parameter 050</p> <p>Display: Parameter 050. flashes, index 00: and value 0 do not.</p>
	<p>Press i/reset to go to parameter bAC_UP.</p> <p>Display: Parameter bAC_UP</p>
	<p>Press + to go to the rEStore function.</p> <p>Display: Parameter rEStore</p>
	<p>Press i/reset to select the restore process.</p> <p>Display: Value 0</p>
	<p>Press + to shift the value in change mode 1 position to the left.</p> <p>Display: Value 1 flashes.</p>
	<p>Note To detect potential display errors, the value is displayed 1 place shifted to the left.</p>

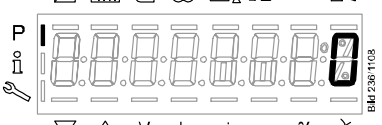
		<p>Press  to activate the restore process.</p> <p>Display: 1 appears</p>
<p>Ca. 8 s</p>		<p>After about 8 seconds (depending on the duration of the program), 0 appears on the display, indicating the end of the backup process.</p> <p>Display: 0</p>



Note

- Before restoring the backup data on the LMV37.4, the latter compares the burner identification and product no. (ASN) with the burner identification and product no. (ASN) of the backup data set. If the data accord, they are restored. If not, the restore process is aborted. In case of abortion, or if an error occurs during the restore process, the display shows a negative value. For error diagnostics, the cause of the error can be determined from the diagnostic code of error message 137 (see *Error code list*). When the restore process is successfully completed, value **0** appears on the display. The LMV37.4 is supplied with undefined burner identification. In that case, the restore process from the AZL2 is possible without having to enter the burner identification in the LMV37.4
- Information **Err C: 136 D: 1** (restore started) is displayed for a short moment



Caution!

- **On completion of the restore process, the sequence of functions and the parameter settings must be checked**
- **If using a variable speed drive, standardization must always be carried out again**

23 Operation of LMV37.4 via the AZL2

23.1 Normal display

Normal display is the standard display in normal operation, representing the highest menu level. From the normal display, you can change to the info, service or parameter level.

23.1.1 Display in standby mode

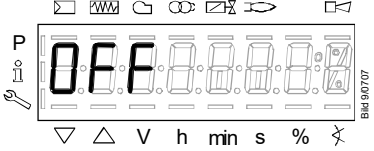

LMV37.4 is in standby mode.

Note!
OFF flashes when the *Manual OFF* function, the manual output, or load controller OFF is activated.

23.1.2 Display during startup / shutdown

23.1.2.1. Display of program phases

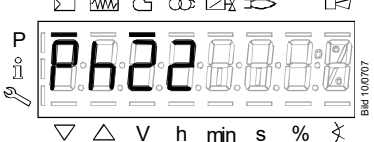

The LMV37.4 is in phase **22**. The load controller calls for heat. The bar below the □ symbol appears. The individual program phases and controlled components are displayed in accordance with the program sequence.

23.1.2.2. Display of program phase with remaining running time until end of the phase is reached





The LMV37.4 is in phase **30** and shows the remaining running time in that phase.

Example: **12 s, phase 30**

23.1.2.3. List of phase displays

Phase	Function
Ph00	Lockout phase
Ph01	Safety phase
Ph10	Home run
Ph12	Standby (stationary)
Ph22	Fan ramp up time (fan motor = ON, safety valve = ON)
Ph24	Traveling to the prepurge position
Ph30	Prepurge time
Ph35	Run the fan to ignition speed
Ph36	Traveling to the ignition position
Ph38	Preignition time
Ph39	Valve proving filling time (test pressure switch-min when mounted between fuel valve V1 and fuel valve V2)
Ph40	1st safety time (ignition transformer ON)
Ph42	1st safety time (ignition transformer OFF)
Ph44	Interval 1
Ph50	2nd safety time
Ph52	Interval 2
Ph60	Operation 1 (stationary)
Ph62	Maximum time low-fire (operation 2, preparing for shutdown, traveling to low-fire)
Ph64	Switching back to pilot: Modulation to ignition load
Ph65	Switching back to pilot: Interval 2 waiting time
Ph66	Switching back to pilot: Reactivation of ignition + pilot
Ph67	Switching back to pilot: Shutdown of main valves
Ph68	Switching back to pilot: Pilot mode waiting phase
Ph69	Switching back to pilot: Pilot mode waiting phase for burner startup
Ph70	Afterburn time
Ph71	Run the fan to postpurge speed
Ph72	Traveling to the postpurge position
Ph74	Postpurge time (no extraneous light test)
Ph78	Postpurge time (abortion when load controller ON)
Ph79	Run the fan to standby speed
Ph80	Valve proving - test space evacuating
Ph81	Valve proving - test time atmospheric pressure
Ph82	Valve proving - test space filling
Ph83	Valve proving - test time gas pressure
Ph90	Gas shortage waiting time

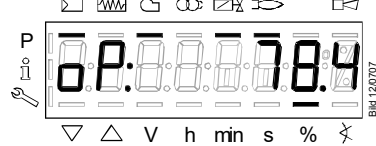
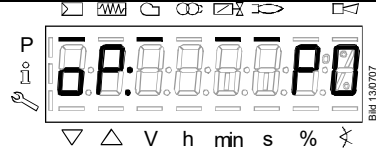
23.1.3 Display of operating position

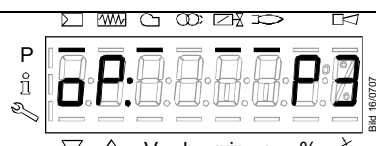
		<p>Display oP stands for <i>Operating position reached</i>. Modulating mode: Current output in %</p>
		<p>Display oP: P0 stands for <i>Ignition point</i>. Multistage operating mode: Current heating stage</p>
		<p>Display oP: P1 stands for <i>Stage 1</i>. Multistage operating mode: Current heating stage</p>
		<p>Display oP: P2 stands for <i>Stage 2</i>. Multistage operating mode: Current heating stage</p>
		<p>Display oP: P3 stands for <i>Stage 3</i>. Multistage operating mode: Current heating stage</p>

23.1.4 Fault status messages, display of errors and info

23.1.4.1. Display of errors (faults) with lockout

	<p>The display shows Loc:, the bar under the fault status message c appears.</p>
	<p>The LMV37.4 is in the lockout position.</p> <p>The display shows current error code c: alternating with diagnostic code d: (refer to <i>Flash code list</i>).</p> <p>Example: Error code 4 / diagnostic code 3</p>

23.1.4.2. Reset

	<p>Press for 1...3 s so that rESEt appears on the display.</p> <p>When you release the button, the LMV37.4 is reset.</p> <p>If you press for >1 s or <1 s, the system returns to the former menu.</p> <p>Exception: If a fault occurs in connection with the curve setting, the system returns to the parameter setting level.</p>
--	---

23.1.4.3. Activating info / service mode from lockout

	<p>Press for >3 s so that InFo, SEr and then OPERAtE appear on the display.</p>
	<p>When the button is released, a change to info / service mode is made.</p>

23.1.4.4. Error with safety shutdown

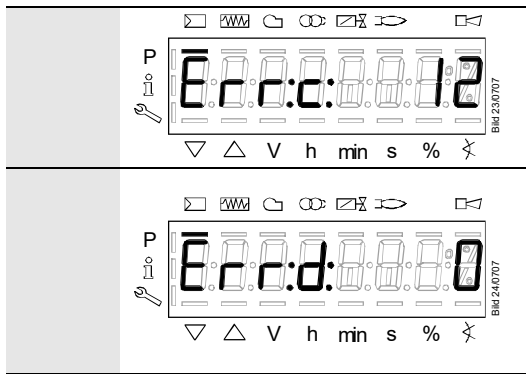

The display shows **Err:**.

The LMV37.4 initiates safety shutdown.

The display shows current error code **c**: alternating with diagnostic code **d**:

Press  **reset** to return to the normal display.

Example: Error code **12** / diagnostic code **0**

23.1.4.5. General information

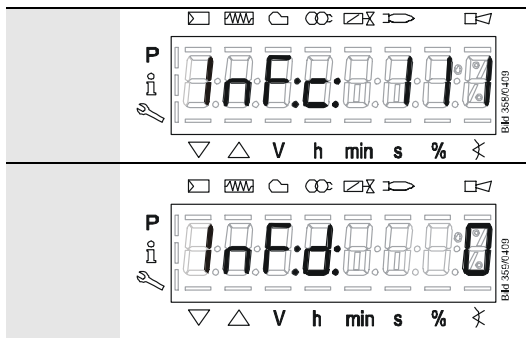

The LMV37.4 displays an event which does not lead to shutdown.

The display shows current error code **c**: alternating with diagnostic code **d**:

Press  **reset** to return to the former menu.

Example: Error code **111** / diagnostic code **0**



Note

For meaning of the error and diagnostic codes, refer to chapter *Error code list*.
When an error has been acknowledged, it can still be read out from the error history.

23.1.4.6. Prevention of startup

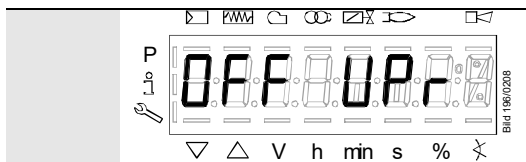

OFF UPPr appears if a LMV37.4 was not programmed or not completely parameterized, or LMV37.4 operating mode was reset or changed.
The display shows **OFF UPPr**.

23.1.4.7. Safety loop

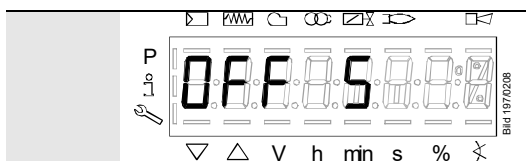

OFF S appears if a LMV37.4 safety loop and / or burner flange contact is open, and a load controller ON signal is present.

24 Menu-driven operation

24.1 Assignment of levels

The various levels can be accessed via different button combinations. The parameter level can only be accessed via password.

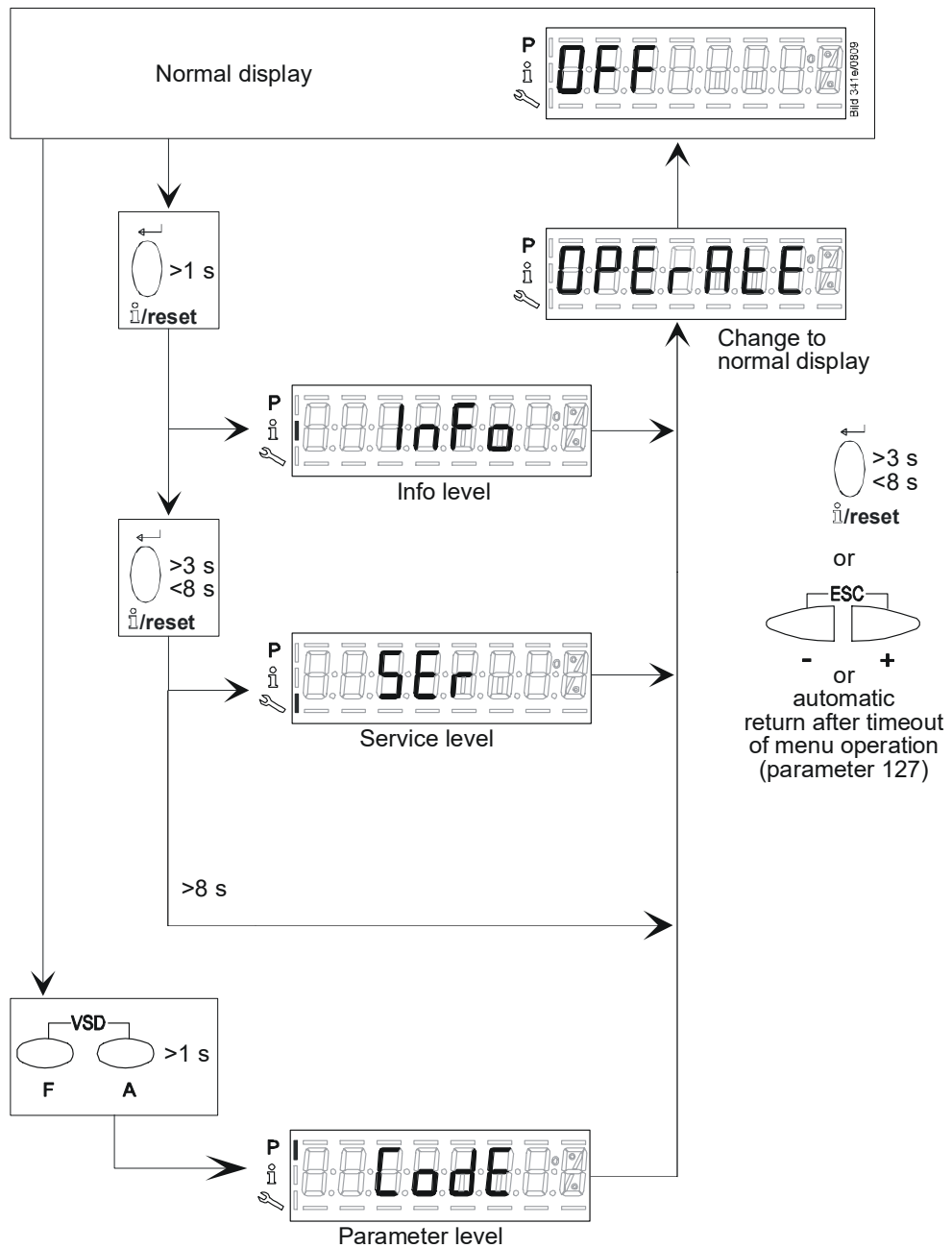
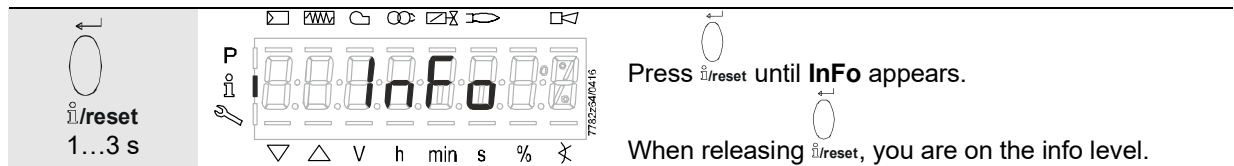

Figure 100: Assignment of levels

25 Info level

25.1 Display of info level



The info level displays information about the LMV37.4 and about operation in general.



Note

On the info level, you can press or to display the next or the previous parameter.

Instead of pressing , you can also press for <1 second.



Note

Press or for >8 seconds to return to the normal display.

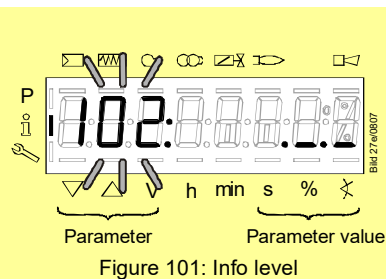

Figure 101: Info level

Note!

No change of values on the info level!

If the display shows below the parameter value, the value may consist of more than 5 digits.

The value is displayed by pressing for >1 s and <3 s.

Press for >3 s or press to return to the selection of the parameter number (parameter no. flashes).

No.	Parameter
Info level	
167	Fuel volume resettable [m ³ , l, ft ³ , gal]
162	Operating hours resettable
164	Number of startups resettable
176	<i>Switching back to pilot</i> switching cycles
163	Operating hours when LMV37.4 is live
166	Total number of startups
113	Burner identification
107	Software version
108	Software variant
102	Identification date
103	Identification number
104	Preselected parameter set: Customer code
105	Preselected parameter set: Version
143	Reserved
End	

25.2 Display of info values (examples)

25.2.1 Identification date

The identification date described below corresponds to the creation date for the program sequence and cannot be changed by the user.



The display shows parameter **102**: flashing on the left, characters **._.** on the right.

Example: **102**: **._.**

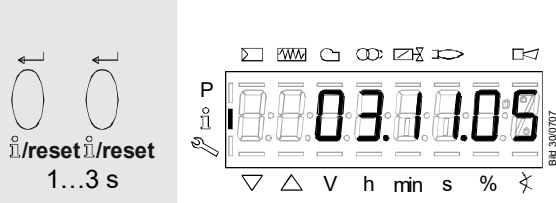

Pressing the button **i/reset** (1...3 seconds) and releasing it when **._.** flashes displays the identification date (creation date of the program sequence) **DD.MM.YY**.

Example: Identification date **03.11.05**

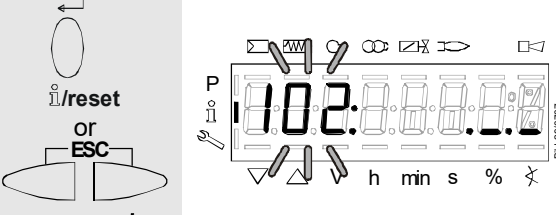

Press the **i/reset** or **ESC** button to return to the display of parameters.

To the next parameter 

25.2.2 Identification number

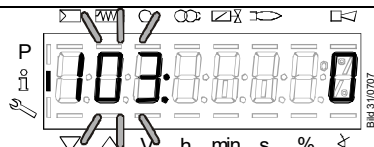

The display shows parameter **103**: flashing on the left, identification number **0** on the right.

Example: **103**: **0**

To the next parameter  or **i/reset** <1 s

 Back to the previous parameter

25.2.3 Burner identification

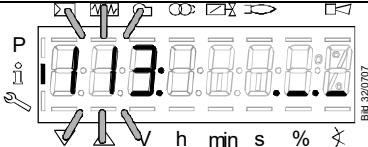

The display shows parameter **113**: flashing on the left, characters **._._** on the right.

Example: **113**: **._._**

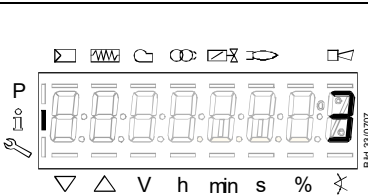



Press  for 1...3 s to show the burner's identification.

Default setting: **-----**

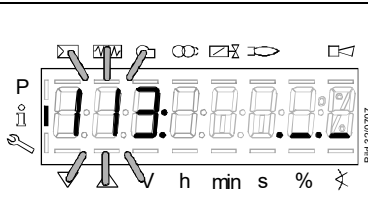
Example: **3**



Press  or  to return to the display of parameters.

The burner's identification can be set on the parameter level!

To the next parameter  **+**

 **-** Back to the previous parameter

25.2.4 Number of startups resettable



Note!
Can be deleted for service refer to chapter *Parameter list!*

The display shows parameter **164**: flashing on the left, characters **. _ . _** on the right, since display of the number of startups may comprise more than 5 digits.

Example: Parameter **164**: **. _ . _**

Pressing the button **i/reset** (1...3 seconds) and releasing it when **. _ . _** flashes displays the number of startups (can be reset).

Example: **36**

Press **i/reset** or **ESC** to show parameter **164** flashing again.

The number of startups can be reset on the parameter level!

To the next parameter **+** **-** Back to the previous parameter

25.2.5 Total number of startups

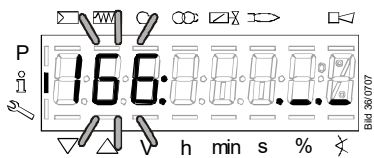

The display shows parameter **166**: flashing on the left, characters **. _ .** on the right, since the display of the total number of startups may comprise more than 5 digits.

Example: Parameter **166**: **. _ .**

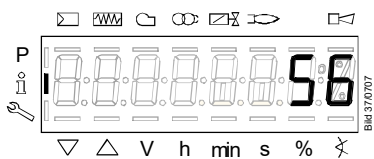

Pressing the button  (1...3 seconds) and releasing it when **. _ .** flashes displays the total number of startups.

Example: **56**

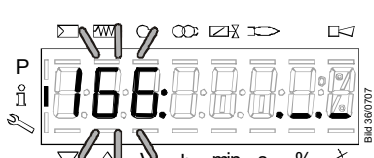

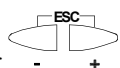
Press  or  to return to the display of parameters.

25.2.6 End of info level

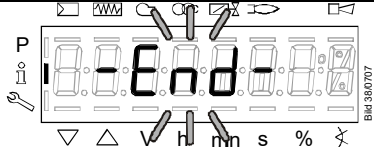

When this display appears, you have reached the end of the info level.

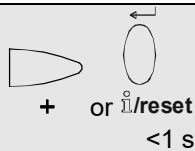

The display shows **- End -** flashing.

To the start of the info level

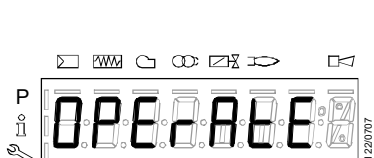

To end of info level

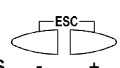
Press  or  (>8 seconds) to return to the operating mode display

OPERAtE appears for a short moment.

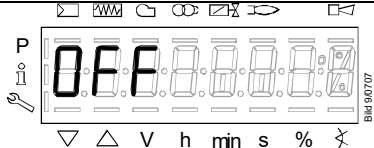

When this display appears, you are back on the normal display and you can change to the next level mode.



Press  to switch between the service and the parameter level.

26 Service level

The service level is used to display information about errors including the error history and information about the LMV37.4.



Note
 When on the service level, you can press or to display the next or the previous parameter.
 Instead of pressing , you can also press for <1 s.



Note
 Press or for >3 s to return to the normal display.



Figure 102: Service level

Note!
 No change of values on the service level.

If characters `._.` are displayed by the parameter, the value may consist of more than 5 digits.

Press for >1 s and <3 s to display the value.

Press for >3 s or to return to the selection of the parameter number (parameter number flashes).

26.1 Display of service level

Press for >3 s until **SEr** appears.

When releasing , you are on the service level.

No.	Parameter
Service level	
954	Intensity of flame
960	Actual flow rate (fuel throughput in m ³ /h, l/h, ft ³ /h, gal/h)
121	Manual output Undefined = automatic operation
922	Incremental position of actuators Index 0 = fuel Index 1 = air
936	Standardized speed
161	Number of faults
701	Error history: 701-725.01.Code <ul style="list-style-type: none"> • Error history: 701-725.02.Diagnostic code • Error history: 701-725.03.Error class • Error history: 701-725.04.Phase • Error history: 701-725.05.Startup counter • Error history: 701-725.06.Output
725	Error history: Oldest error in the history

26.2 Display of service values (example)

26.2.1 Number of faults

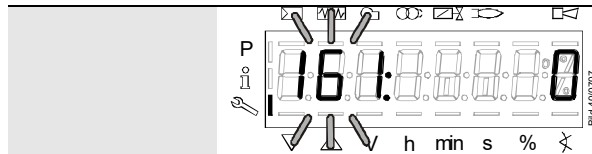

The display shows parameter **161**: flashing on the left, the number of faults that occurred thus far on the right **0**.

Example: Parameter **161: 0**

To the next parameter

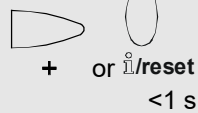

Back to the previous parameter

26.2.2 Error history

Refer to chapter *Parameter with index, without direct display/Example of parameter 701: Error history!*



Note

Can be deleted for service (refer to chapter *Parameter list!*)

26.2.3 Intensity of flame

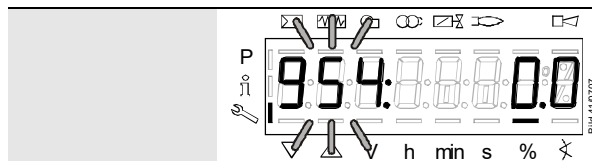

The display shows parameter **954**: flashing on the left.

On the right, the flame's intensity is displayed as a percentage.

Example: **954: 0.0**

To the next parameter

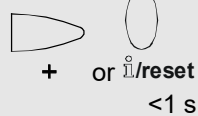

Back to the previous parameter



Note

Also refer to chapter *Intensity of flame during curve settings.*

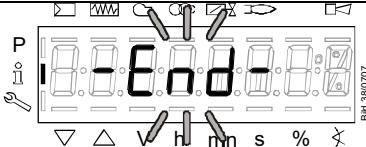

26.2.4 End of service level

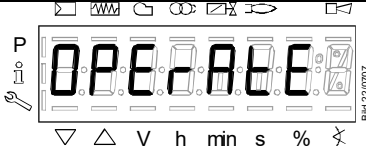

When this display appears, you have reached the end of the service level.
Display **-End-** appears flashing.

To the start of the service level  +  - To the end of the service level



Press  -  + to return to the normal display.
OPERAtE appears for a short moment.

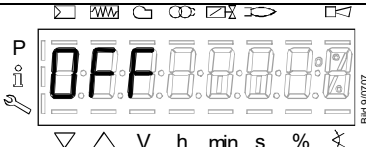

When this display appears, you are back on the normal display and you can change to the next level mode.

27 Parameter level

The parameters stored in the LMV37.4 can be displayed or changed on the parameter level.

The change to the parameter level requires a password.

Siemens supplies the LMV37.4 with the factory settings according to *Type summary*.

The OEM can change the Siemens default settings to match his own requirements.

With the LMV37.4, the LMV37.4's characteristics are determined primarily through parameter settings. Every time the unit is recommissioned, the parameter settings must be checked. The LMV37.4 must never be transferred from one plant to another without matching the unit's parameters to the new plant.

Caution!

Parameters and settings may only be changed by **qualified personnel**.

If parameters are changed, responsibility for the new parameter settings is assumed by the person who – in accordance with the access rights – has made parameter changes on the respective access level.

After parameterization, the OEM must check to ensure that safe burner operation is warranted.

The OEM which made the settings is always responsible for the parameters, their settings and compliance of the respective application with the relevant national and international standards and safety regulations, such as EN 267, EN 676, EN 746-2, EN 1643, etc.

Siemens, its suppliers and other Group Companies of Siemens AG do not assume responsibility for special or indirect damage, consequential damage, other damage, or damage resulting from wrong parameter settings.



Warning!

If the factory settings are changed, all changes made must be documented and checked by the OEM.

The OEM is obliged to mark the LMV37.4 accordingly and to include at least the list of device parameters and settings in the burner's documentation.

Siemens also recommends attaching an additional mark on the LMV37.4 in the form of an adhesive label. According to DIN EN 298, the label should be easy to read and wipe proof.

The label with a maximum size of 70 mm x 45 mm can be attached to the upper part of the housing.



Example of label:

OEM logo

Type / part no.: 1234567890ABCD

Caution! OEM settings:

Parameter

225 = 30 s (t1)

226 = 2 s (t3)

230 = 10 s (t4)

234 = 0 s (t8)

240 = 1 (Restart)

257 = 2 s (t3n)

TSA = t3n + 0.7 s

259 = 30 s (t11)

260 = 30 s (t12)

27.1 Entry of password



Note

The **OEM's** password must consist of **5** characters, the **heating engineers** of **4** characters.

		<p>Press button combination to display Code.</p>
		<p>When releasing the buttons, 7 bars appear the first of which flashes.</p>
		<p>Press or to select a number or letter.</p>
		<p>Press to confirm the value.</p> <p>The value entered changes to a minus sign (-).</p> <p>The next bar starts flashing.</p>
		<p>Press or to select a number or letter.</p>
		<p>After entry of the last character, the password must be confirmed by pressing .</p> <p>Press again to end the password entry.</p> <p>Example: Password consisting of 4 characters.</p>

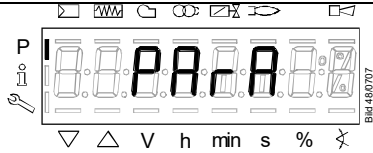

As a confirmation of correct entry, **PARA** appears for a maximum of 2 seconds.



Note

For entry of passwords or burner IDs, the following numbers and letters can be used:

	= 1		= A		= L
	= 2		= b		= n
	= 3		= C		= o
	= 4		= d		= P
	= 5		= E		= r
	= 6		= F		= S
	= 7		= G		= t
	= 8		= H		= u
	= 9		= I		= Y
	= 0		= J		

27.2 Entry of burner identification

The burner's identification is entered like a password (character by character), but from right to left and ending with «_».

		<p>Parameter 113: flashes.</p> <p>Press to go to editing mode.</p>
		<p>You are on the display for undefined burner identification. 8 bars appear.</p>
		<p>Press or to select a number. Example: Number 3 flashes.</p>
		<p>Press to confirm the value. Make the entry number by number.</p>
		<p>Press or to select the next number. Example: Number 9 flashes.</p>
		<p>After entry of the last number, burner identification must be confirmed by pressing .</p>

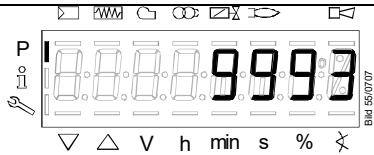

The display no longer flashes.
Example: Burner identification **9999**

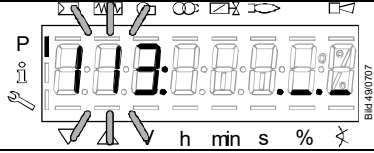
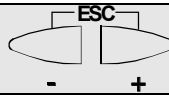

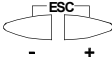
Press  to return to the parameter level.

PArAmeter **113**: for burner identification.

27.3 Change of heating engineer's password









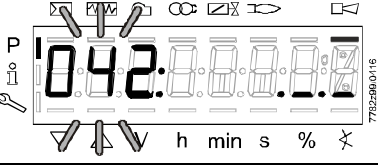

Note!

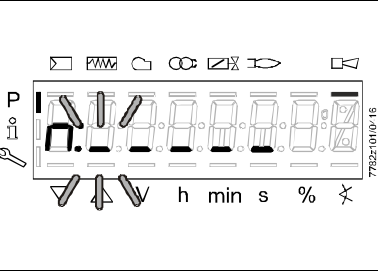
For the OEM to change the heating engineer's password, c: requires entry of the OEM password!

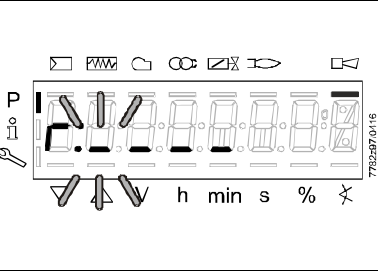

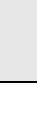
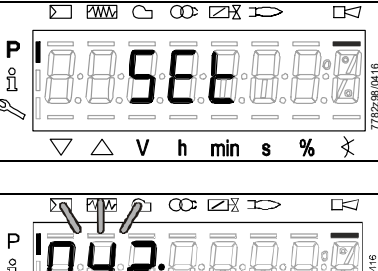

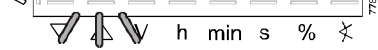
		<p>Press button combination to display 000: Int.</p> <p>Pressing the button takes you to parameter 041 heating engineer's password.</p>
		<p>Parameter 041: flashes.</p> <p>Press to go to level c: for password changes.</p>
		<p>Letter n: for new appears flashing.</p> <p>Proceed as described in chapter <i>Entry of password</i> and enter the new password (4 characters).</p> <p>After entry of the last character, the password must be confirmed by pressing .</p>
		<p>Letter r: for repeat appears flashing.</p> <p>Proceed as described in chapter <i>Entry of password</i> and repeat entry of the new password.</p> <p>After entry of the last character, the password must be confirmed by pressing .</p>
		<p>SEt confirms that the new password has been saved.</p>
		<p>Pressing the button takes you to parameter 041 heating engineer's password.</p>
<p>Continue in the parameter level to the next parameter group 100:</p>		<p>End of the parameter level -End-</p>

27.4 Change of OEM's password

		<p>Parameter 042: flashes.</p>
		<p>Press  to go to level c: for password changes.</p>
		<p>Letter n: for new appears flashing.</p> <p>Proceed as described in chapter <i>Entry of password</i> and enter the new password (5 characters).</p> <p>After entry of the last character, the password must be confirmed by pressing .</p>
		<p>Letter r: for repeat appears flashing.</p> <p>Proceed as described in chapter <i>Entry of password</i> and repeat entry of the new password.</p> <p>After entry of the last character, the password must be confirmed by pressing .</p>
		<p>SEt confirms that the new password has been saved.</p>
		<p>Parameter 042: flashes again.</p>

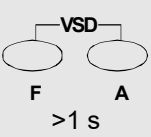
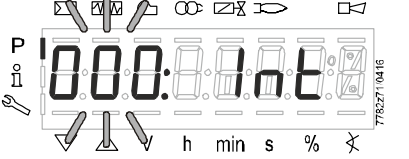
27.5 Use of parameter level

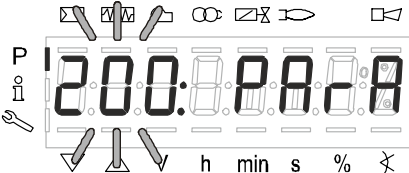
The parameters stored in the LMV37.4 can be displayed and changed on the parameter level. Normally, all parameters have been set by the burner manufacturer – with the exception of those for the fuel train and for fuel-air ratio control. A description of parameter level **400**, which is used for setting the fuel train and the fuel-air ratio curve, is given in chapter *Fuel-air ratio curves – settings and commissioning*.

		 <p>Press button combination F A to display 000: Int.</p> <p>With +, select the parameter group 100: PArA.</p>
		<p>With +, select the parameter group 200: PArA.</p>  <p>Pressing the reset button takes you to parameter 201: Burner operating mode.</p>

27.6 Structure of parameter levels

The parameters are assigned to different levels.



Bild 384e/1209

Figure 103: Structure of parameter levels

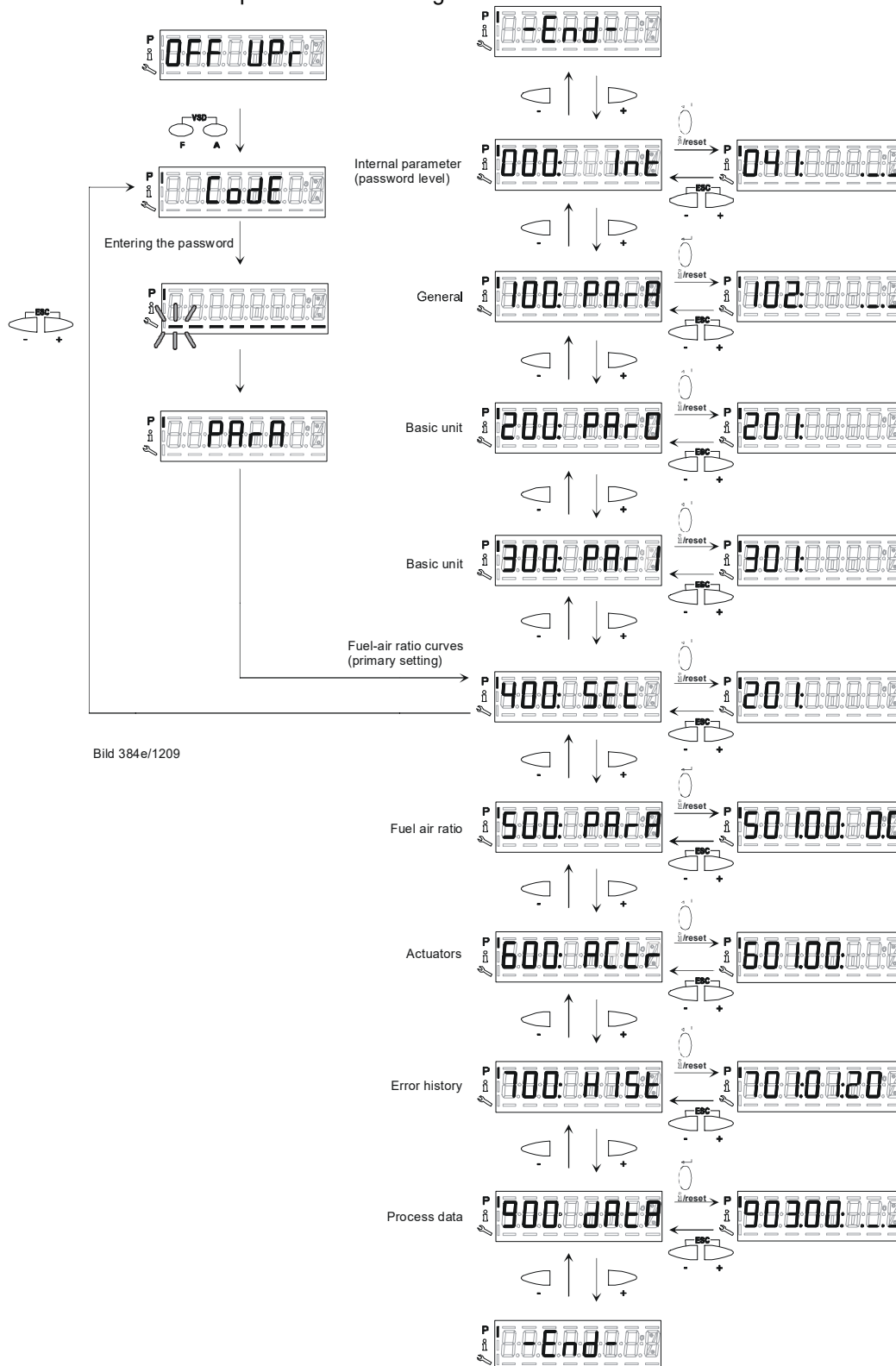

Note

The following sections explain the operating philosophy behind the parameter levels using a number of examples.



Caution!

Pay special attention to chapter **Safety notes on settings and parameter settings!**

27.7 Parameters without index, with direct display

27.7.1 Using the example of parameter 208: Program stop

		<p>PARAmeter level 200: for LMV37.4.</p>
		<p>Press to go to menu level 200:</p>
		<p>Press to select <i>Program stop</i>. Display: Parameter 208: flashes, value 0 does not.</p>
		<p>Press to go to editing mode. Display: Program stop time set Here: Value 0 → corresponding to program stop deactivated.</p>
		<p>Press or to select the required program stop time.</p> <ul style="list-style-type: none"> 0 = deactivated 1 = prepurge position (phase 24) 2 = ignition position (phase 36) 3 = interval 1 (phase 44) 4 = interval 2 (phase 52) <p>Example: 2 ignition position (phase 36)</p>

Adopt the value!

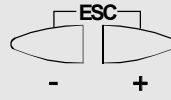
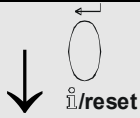

Discard the change!

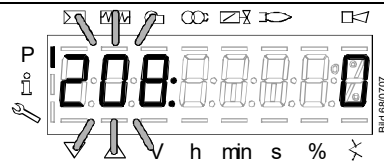
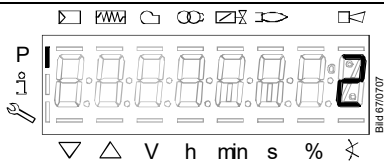

Press  to return to editing mode.

The value set is adopted.

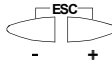

Note
To detect potential display errors, the value is displayed 1 place shifted to the right.

Press  - + to return to the parameter level.

Display: Parameter **208**: flashes, value **0** does not.

Display: Value **2**

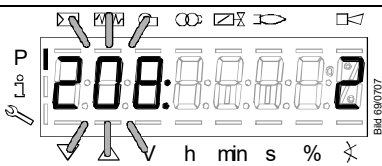
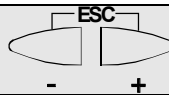

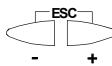
Press  - + to return to the parameter level.

PARAmeter 208: flashes, value **2** does not.

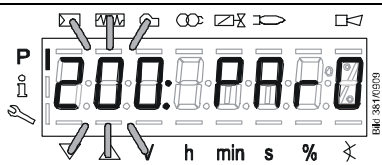
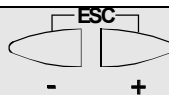

Press  - + to return to the parameter level.

PARAmeter 200: for LMV37.4.

To the next parameter level



Back to the previous parameter level

27.8 Parameters without index, with no direct display (with parameters having a value range >5 digits)

27.8.1 Using the example of parameter 162: Operating hours resettable

		<p>PARAmeter level 100: for general.</p>
		<p>Press to go to menu level 100.</p>
		<p>Press to select <i>Operating hours resettable</i>.</p> <p>Display: Parameter 162: flashes, characters -.- do not.</p>
		<p>Press to go to editing mode.</p> <p>Display: 123457</p>
		<p>You can press or to set the number of operating hours to 0.</p> <p>Display: Operating hours 0 flashes.</p>

Adopt the value!

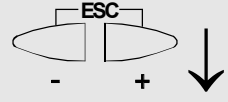
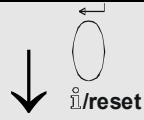

Discard the change!

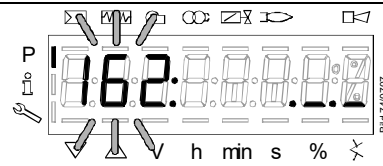
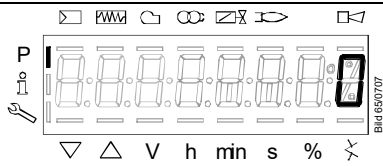

Press  **i/reset** to return to editing mode.

The value set will be adopted.

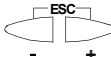

Note
To detect potential display errors, the value is displayed 1 place shifted to the right.

Press  **- +** to return to the parameter level.

Display: Parameter **162**: flashes, characters **-.-** do not.

Display: Value **0**

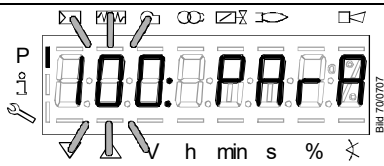
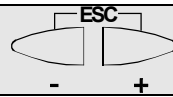

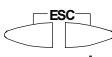







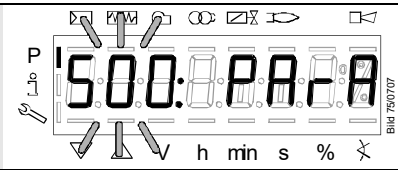

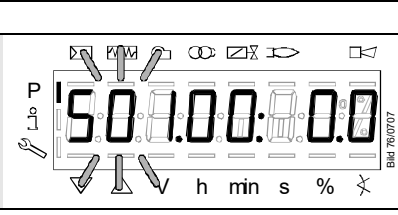

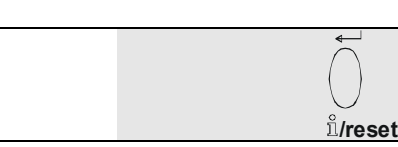
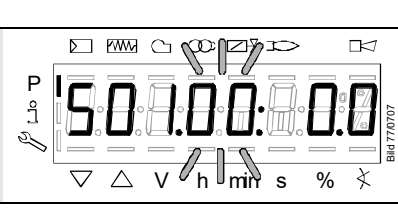
Press  **- +** to return to the parameter level.

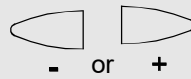
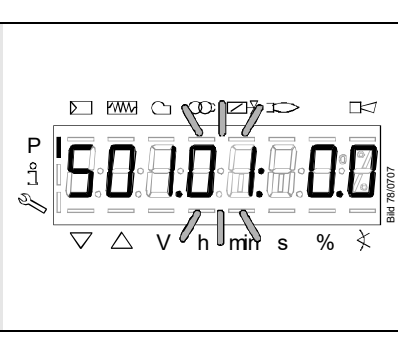
PARAmeter 100: for general.

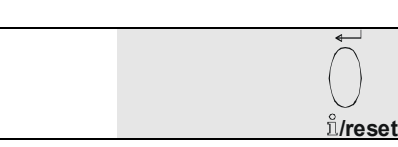
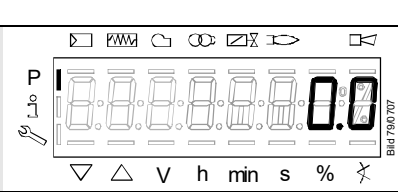
27.9 Parameter with index, with direct display

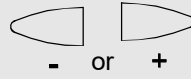
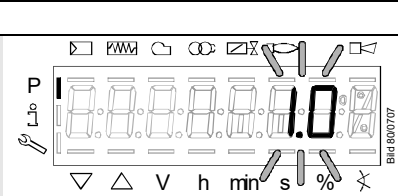
27.9.1 Using the example of parameter 501: No-flame positions fuel actuator

		<p>PARAmeter level 500: for fuel-air ratio control.</p>
		
		<p>Press  to go to menu level 500:. Display: Parameter 501. flashes, index 00: and value 0.0 do not.</p>
		
		<p>Press  to go to the index. Display: Parameter 501. does not flash, index 00: flashes, value 0.0 does not.</p>
		<p>Press  or  to select the required index. .00 = home position .01 = prepurge position .02 = postpurge position Display: Index 01: for prepurge position flashes, value 0.0 does not.</p>
		
		<p>Press  to go to editing mode. Display: Value 0.0</p>
		<p>Press  or  to select the required prepurge position. Example: 1.0</p>

Adopt the value!

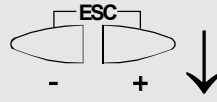
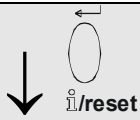

Discard the change!

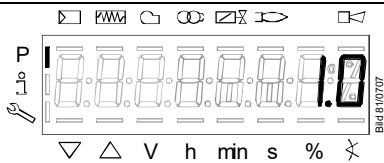

Press  to return to editing mode.

The value set will be adopted.



Note
To detect potential display errors, the value is displayed 1 place shifted to the right.

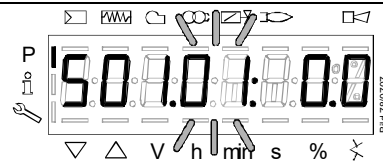

Press  to return to the index.

Display: Parameter **501**. does not flash, index **01**: flashes, value **0.0** has not changed and does not flash.

Display: Value **1.0**

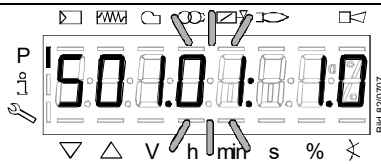
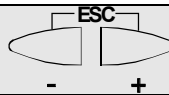

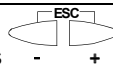
Press  to return to the index.

PARAmeter **501**: does not flash, index **01**: flashes, value **1.0** does not.

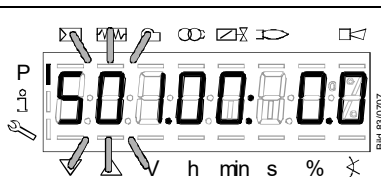
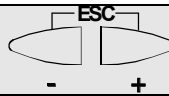

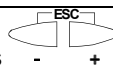
Press  to return to the parameter level.

Display: Parameter **501**. flashes, index **00**: and value **0.0** do not.

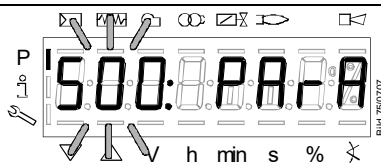
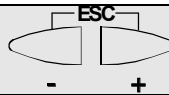

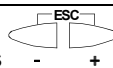
Press  to return to the parameter level.

PARAmeter **500**: for fuel-air ratio control.

27.10 Parameters with index, with no direct display

27.10.1 Using the example of parameter 701: Errors

Refer to chapter *Error code list!*



Note

Can be deleted for service, refer to chapter *Parameter list!*

		<p>HIStory 700: for error history.</p>
		<p>Press to go to the parameter level.</p>
		<p>Press to select parameter 701.</p> <p>Display: Parameter 701. flashes, index 01: and value 201 do not.</p>
		<p>Press to go to index 01:</p> <p>Display: Parameter 701. does not flash, index 01: flashes, value 201 does not.</p>
<p>To the next index</p>		<p>Back to the previous index</p>
		<p>Press to select the index:</p> <ul style="list-style-type: none"> .01 = error code .02 = diagnostic code .03 = error class .04 = error phase .05 = startup counter .06 = output <p>Example: Parameter 701., index 05: for startup counter, diagnostic code -.-</p>



reset

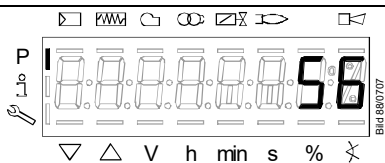

Press reset to go to display mode.

Display: Value 56

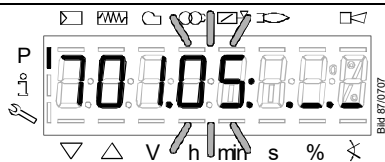
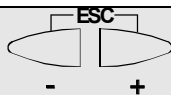

Press - + to return to the index.

Display: Parameter 701. does not flash, index 05: flashes, characters '--' do not.

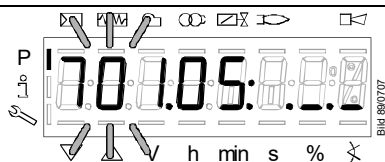
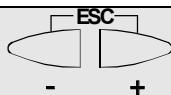

Press - + to return to the parameter level.

Display: Parameter 701. flashes index 05: does not, characters '--' do not.

To the next older error



+

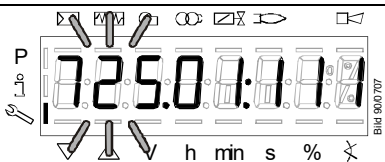

Parameters cover the period of time back to the last error since history was deleted (max. to parameter 725.)

Example:
Parameter 725., index 01:, error code 111

To the next parameter



+



Back to the previous parameter

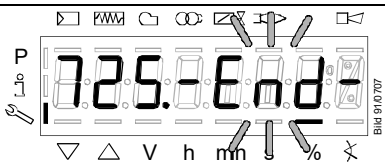

When this display appears, you have reached the end of the error history index.

Display - End - appears flashing.

To the next parameter



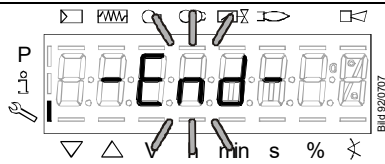

Back to the previous parameter

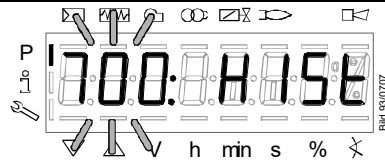
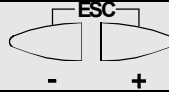

When this display appears, you have reached the end of the error history.

Display **- End -** appears flashing.



Press  to return to the parameter level.

HISt 700: for error history

To the next parameter

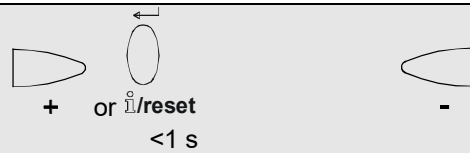

Back to the previous parameter



Note

If you wish, you can delete the error history via parameter **130**.

To delete the display, set the parameter to **1** and then to **2**.

The error history is deleted when the parameter returns to **0**.

27.11 Fuel-air ratio curves – settings and commissioning

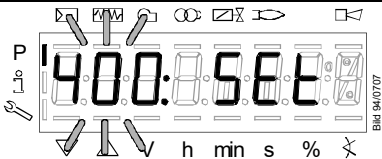

The display shows **400**: flashing on the left, **SEt** appears on the right.

27.11.1 Initial commissioning

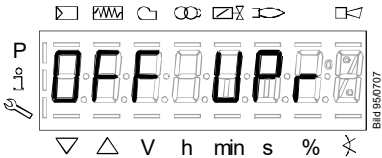

An unprogrammed LMV37.4 or a LMV37.4 whose operating mode has been reset or changed displays **OFF UPr**.

For initial commissioning, change to the parameter level (refer to chapter *Operation*). The settings can then be made on parameter level **400**.

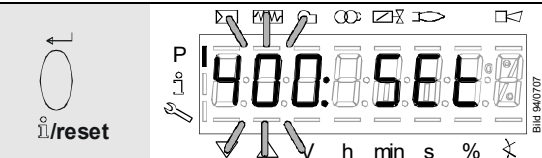

Press **i/reset** to select parameter **400** for initial commissioning and for setting fuel-air ratio control.

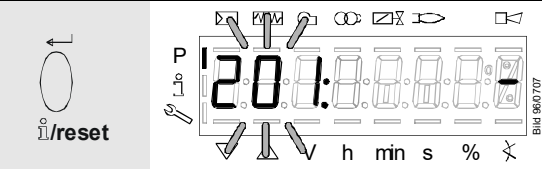

Press **i/reset** to go to the settings for fuel-air ratio control and parameter **201** for selecting the operating mode.

201: appears flashing.



Note

Ensure that the fuel train is correctly set in compliance with the type of burner used.

No.	Parameter	Actuator controlled	
		Air	Fuel
201	Burner operating mode (fuel train, modulating / multistage, actuators, etc.)	●	●
	-- = undefined (delete curves)	●	●
	1 = gas modulating (G mod)	●	●
	2 = gas modulating with pilot valve 1 (Gp1 mod)	●	●
	3 = gas modulating with pilot valve 2 (Gp2 mod)	●	●
	4 = oil modulating (Lo mod)	●	●
	5 = oil 2-stage (Lo 2 stage)	●	---
	6 = oil 3-stage (Lo 3 stage)	●	---
	7 = gas modulating pneumatic (G mod pneu)	●	---
	8 = gas modulating pneumatic with pilot valve 1 (Gp1 mod pneu)	●	---
	9 = gas modulating pneumatic with pilot valve 2 (Gp2 mod pneu)	●	---
	10 = oil modulating with pilot valve (LoGp mod)	●	●
	11 = oil 2-stage with pilot valve 2 (LoGp 2-stage)	●	---
	12 = oil modulating with 2 fuel valves (Lo mod 2 fuel valves)	●	●
	13 = oil modulating with pilot valve and 2 fuel valves (LoGp mod 2 fuel valves)	●	●
	14 = gas modulating pneumatic without actuator (G mod pneu without actuator, 0 active)	---	---
	15 = gas modulating pneumatic with pilot valve 1 without actuator (Gp1 mod pneu without actuator, 0 active)	---	---
	16 = gas modulating pneumatic with pilot valve 2 without actuator (Gp2 mod pneu without actuator, 0 active)	---	---
	17 = oil 2-stage without actuator (Lo 2-stage without actuator, 0 active)	---	---
	18 = oil 3-stage without actuator (Lo 3-stage without actuator, 0 active)	---	---
	19 = gas modulating only gas actuator (G mod only gas actuator, fuel active)	---	●
	20 = gas modulating with pilot valve 1 only gas actuator (Gp1 mod only gas actuator, fuel active)	---	●
	21 = gas modulating with pilot valve 2 only gas actuator (Gp2 mod only gas actuator, fuel active)	---	●
	22 = oil modulating only oil actuator (Lo mod only oil actuator, fuel active)	---	●
	23 = heavy oil modulating with circulation control (Ho mod separate circulation control)	●	●
	24 = heavy oil 2-stage with circulation control (Ho 2 stage separate circulation control)	●	---
	25 = heavy oil modulation without circulation control (Ho mod without circulation control)	●	●
	26 = heavy oil 2-stage without circulation control (Ho 2 stage without circulation control)	●	---
	27 = heavy oil 3-stage without circulation control (Ho 3 stage without circulation control)	●	---
	28 = gas modulating mechanical only air actuator (G mod mech only fuel active, fuel active)	●	---
	29 = gas modulating mechanical with pilot valve 2 only air actuator (Gp2 mod mech only air actuator, fuel active)	●	---

Press to go to editing mode.

Press or to select the required setting.

Example: **3** for gas modulating with pilot valve (Gp2 mod)

Press to save the selected setting.

Press to return to the parameter level.

To the next parameter



Press to change to parameter **542**: to activate the VSD / PWM fan.

You can choose:
 0 = VSD / PWM fan OFF
 1 = VSD / PWM fan ON

To the next parameter



Back to the previous parameter

Press to change to parameter **641**: to control speed standardization of the VSD.

You can choose:
 0 = speed standardization of VSD OFF
 1 = speed standardization of VSD ON

After setting speed standardization to **1**, standardization of the VSD commences. If successful, the parameter is reset to **0**. Negative values indicate errors (refer to chapter *Automatic speed standardization*).

To the next parameter



- For operating modes 1...4, 7...10, 12...16 and 19...22, refer to chapter *Setting curvepoints P0 and P9 for modulating mode («G mod», «Gp1 mod», «Gp2 mod» and «Lo mod»)*
- For operating modes 5, 6, 11, 17 and 18, refer to chapter *Setting the curvepoints for multistage mode («Lo 2-stage» and «Lo 3-stage»)*

27.11.2 Setting curvepoints P0 and P9 for modulating operation («G mod», «Gp1 mod», «Gp2 mod» and «Lo mod»)



Note

Not all actuators used in the following example can be set, depending on the selected operating mode.

Example of «G mod»

		<p>Display P0 appears blinking.</p> <p>Curvepoint for ignition load.</p>
		<p>Keep F depressed.</p> <p>You are now in setting P0 of fuel setting F for ignition position P0.</p>
		<p>Press simultaneously F and - or + to set ignition position P0 of the fuel damper.</p> <p>Example: 30.0</p>
		<p>Release F.</p> <p>The selected value is adopted.</p> <p>Example: 30.0</p>
		<p>Keep A depressed.</p> <p>You are now in setting P0 of air actuator A for ignition position P0.</p>
		<p>Press simultaneously A and - or + to set ignition position P0 of the air actuator.</p> <p>Example: 22.0</p>
		<p>Release A.</p> <p>The selected value is adopted.</p> <p>Example: 22.0</p>
		<p>Keep F and A depressed.</p> <p>You are now in setting n0, speed n is for ignition position n0</p>

Press simultaneously **F** and **A** and **-** or **+** to adjust speed **n0** of the VSD.
Example: **20.0**

Release **F** and **A**.
The selected value is adopted.
Example: **20.0**

To the next curvepoint



Press **+**.

P9 appears blinking.

Curvepoint for high-fire.

Same procedure as with **P0**

Note!
If **-** is pressed first, the display jumps to 90!

To the next curvepoint



Back to the previous curvepoint

Press **+**.

The display shows **run** (identification of start for setting the curve parameters).



Note!

You now have the option of pressing to proceed with the warm settings (see section *Warm settings for modulating operation* «G mod», «Gp1 mod», «Gp2 mod» and «Lo mod») or pressing to proceed with the cold settings (see section *Cold settings for* «G mod», «Gp1 mod», «Gp2 mod» and «Lo mod») of the LMV37.4.

27.11.3 Setting curvepoints P0 and P9 for «G mod pneu», «Gp1 mod pneu» and «Gp2 mod pneu»



Note!

Refer to chapter *Setting curvepoints P0 and P9 for modulating operation* («G mod», «Gp1 mod», «Gp2 mod» and «Lo mod»)! Here, only the air requires adjustment with .

27.11.4 Warm settings for modulating operation («G mod», «Gp1 mod», «Gp2 mod» and «Lo mod»)



Note

With the *warm settings*, the burner is started up after pressing the **Info** button. Fuel-air ratio control can now be accurately set while the flame is present. When traveling along the precalculated curve to high-fire point **P9**, all intermediate curvepoints (**P2...P8**) must be set. Automatic operation is released when – after reaching **P9** – the curve settings are quit by pressing **ESC**. If the curve settings are aborted earlier (**ESC** or shutdown due to fault), prevention of startup **OFF UPr** continues to be active until all points are set. If required, the gas pressure can be set at the high-fire point. In case the gas pressure is changed, all points must be checked by traveling along the curve downward and – if required – readjusted.

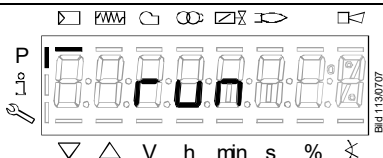

Identification of start for setting the curve parameters.

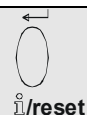

When there is a request for heat.



Note

If, during the time the curve is parameterized, an error occurs which leads to safety shutdown, parameterization of the curve is quit.



Phase *Standby* (stationary)

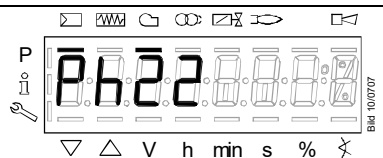

Phase *Fan ramp up*
(fan motor = ON, safety valve = ON)



Phase *Traveling to prepurge position*

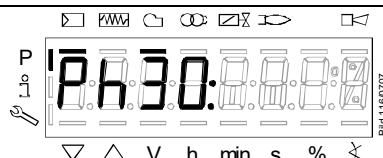

Phase *Prepurging*

Phase *Traveling to ignition position*

Wait until the burner is operating and symbol ▲ or ▼ is no longer highlighted!
 The startup sequence stops in phase 36 *Traveling to ignition position*.
 The ignition point can be adjusted under cold conditions.

Ignition position **P0** can only be set after symbol ▲ or ▼ is no longer highlighted.

For fuel, keep **F** depressed, for air **A**, as well as for VSD **F** and **A**

Press **-** or **+** to adjust the value.

When symbol ▲ or ▼ is no longer highlighted, the next curvepoint **P1** can be selected with **+**.

Phase *Traveling to ignition position*

Phase *Preignition*

Phase *1st safety time (ignition transformer ON)*

Phase *1st safety time (ignition transformer OFF), preignition time OFF*

Phase *Interval 1*

Starting the warm settings

○ ○
F or A
and
▴ ▾
- or +
as well as
○ ○
F and A
and
▴ ▾
- or +

Ignition position **P0** can only be set when symbol ▲ or ▼ is no longer highlighted.

For fuel, keep [○]F depressed, for air [○]A, as well as for VSD [○]F and [○]A

Press ▴ or ▾ to adjust the value.

When symbol ▲ or ▼ is no longer highlighted, the next curvepoint **P1** can be selected with [▴] + .

▴
+

○ ○
F or A
and
▴ ▾
- or +
as well as
○ ○
F and A
and
▴ ▾
- or +

Low-fire position **P1** can only be set when symbol ▲ or ▼ is no longer highlighted.

The value is adopted from **P0**.

For fuel, keep [○]F depressed, for air [○]A, as well as for VSD [○]F and [○]A

Press ▴ or ▾ to adjust the value.

When symbol ▲ or ▼ is no longer highlighted, the next curvepoint **P2** can be selected with [▴] + .

▴
+
 ▾
-

When changing from **P1** to **P2** for the first time, curvepoints **P2...P8** automatically calculated and saved.

CALC appears for a short moment.

To the next curvepoint ▴ +
Back to the previous curvepoint ▾ -

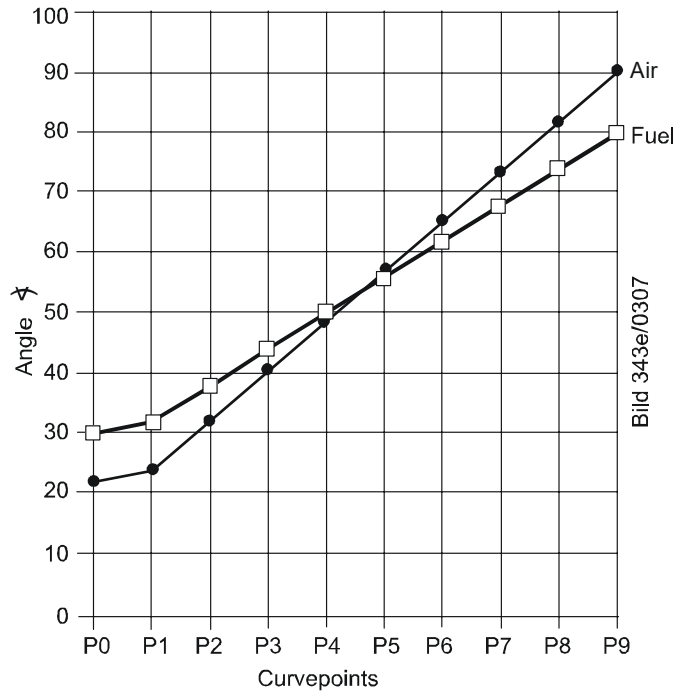

Figure 104: Setting the curvepoints



Note

Curvepoints **P2 to P8** are automatically computed as a straight line between **P1** and **P9**.

Example 1 = gas modulating

P0, P1 and P9 are set as described:

Curvepoint	Value 1 fuel	Value 2 air
P0	30.0	22.0
P1	32.0	24.0
P9	80.0	90.0

P2 through P8 have automatically been calculated:

Curvepoint	Value 1 fuel	Value 2 air
P2	38.0	32.3
P3	44.0	40.5
P4	50.0	48.8
P5	56.0	57
P6	62.0	65.3
P7	68.0	73.5
P8	74.0	81.8

Continue the same way with P2 through P9!

F or A
and
- or +
as well as
F and A
and
- or +

Bild 126/0707

High-fire position **P9** can only be set when symbol ▲ or ▼ is no longer highlighted. If required, readjust the gas pressure.

For fuel, keep **F** depressed, for air **A**, as well as for VSD **F** and **A**

Press **-** or **+** to adjust the value. When symbol ▲ or ▼ is no longer highlighted, the next curvepoint **P8** can be selected with **-**.

After setting the high-fire (P9), either a change to parameter 546 (automatic operation) can be made (ESC) or all curvepoints can be run through in the reverse order. If the gas pressure is changed, all points must be checked and – if required – readjusted.

ESC

- +

Bild 126/0707

The maximum capacity is displayed. If the display shows - - - -, the maximum capacity has not yet been specified. The LMV37.4 can be run up to 100%.

You can press to go to editing mode, enabling you to change the maximum capacity.

To the next parameter

+

Bild 127/0707

The minimum capacity is displayed. If the display shows - - - -, the minimum capacity has not yet been entered. The LMV37.4 can be run down to 20%.

You can press to go to editing mode, enabling you to change the minimum capacity.

ESC

- +

Completing parameterization of the curve

-

Back to the previous parameter

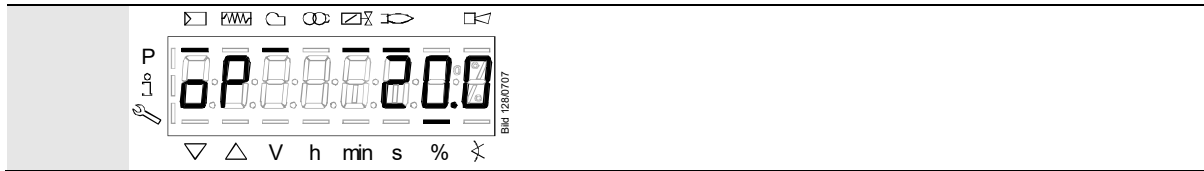
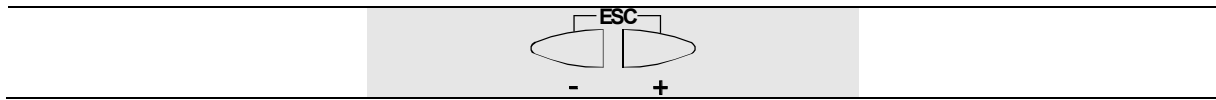
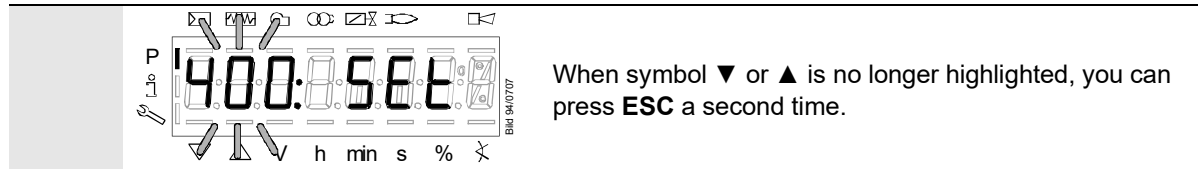

The warm settings for fuel-air ratio control by the LMV37.4 are now completed.

27.11.5 Warm settings for modulating mode («G mod pneu», «Gp1 mod pneu» and «Gp2 mod pneu»)



Note

Refer to chapter *Warm settings for modulating mode («G mod», «Gp1 mod», «Gp2 mod» and «Lo mod»)*! Here, only the air requires adjustment with **A**.

27.11.6 Cold settings for «G mod», «Gp1 mod», «Gp2 mod» and «Lo mod»



Note

Refer to chapter *Warm settings for modulating mode («G mod», «Gp1 mod», «Gp2 mod» and «Lo mod»)*!
With no flame, however, no actuator travel and no automatic operation after the settings have been made.

If **run** is shown in the display, the following must be observed:

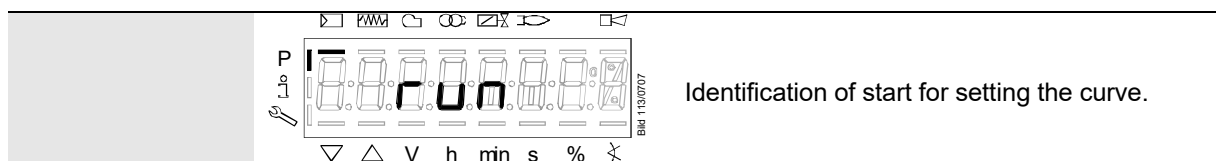

Note!

You now have the option of pressing  to continue with the cold setting for the LMV37.4.

27.11.7 Cold settings for «G mod pneu», «Gp1 mod pneu» and «Gp2 mod pneu»

Note



Refer to chapter *Warm settings for modulating mode* («G mod», «Gp1 mod», «Gp2 mod» and «Lo mod»)!

With no flame, however, no actuator travel and no automatic operation after the settings have been made. Here, only the air requires adjustment with  A .

If **run** is shown in the display, the following must be observed:

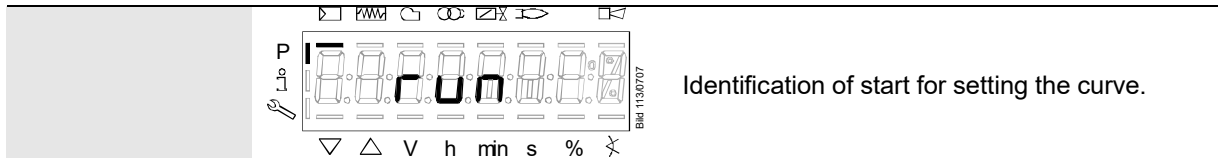

Note!



You now have the option of pressing  - + to continue with the cold setting for the LMV37.4.

27.11.8 Editing the curvepoints



Note

Changing a curvepoint in the cold position requires a new approach to all curvepoints in the warm position to verify the change on the burner itself. After changing the curvepoint, the normal display of the AZL2 shows **OFF UPr**.

To the next curvepoint		or		to select the curvepoint
				The selected curvepoint is displayed.
				Keep F depressed.
				The fuel actuator has been selected for changing.
				Keep F depressed and press - or + to adjust the fuel actuator.
				In the case of warm settings, the actuator follows directly the adjustments made.
				The changes are saved.
				After releasing F , the point is selected again.
				Keep A depressed.
				The air actuator has been selected for editing.
				Keep A depressed and press - or + to adjust the air actuator.
				In the case of warm settings, the actuator follows directly the adjustments made.
				The changes are saved.
				After releasing A , the point is selected again.
To the next curvepoint				Back to the previous curvepoint

27.11.9 Interpolating the curvepoints

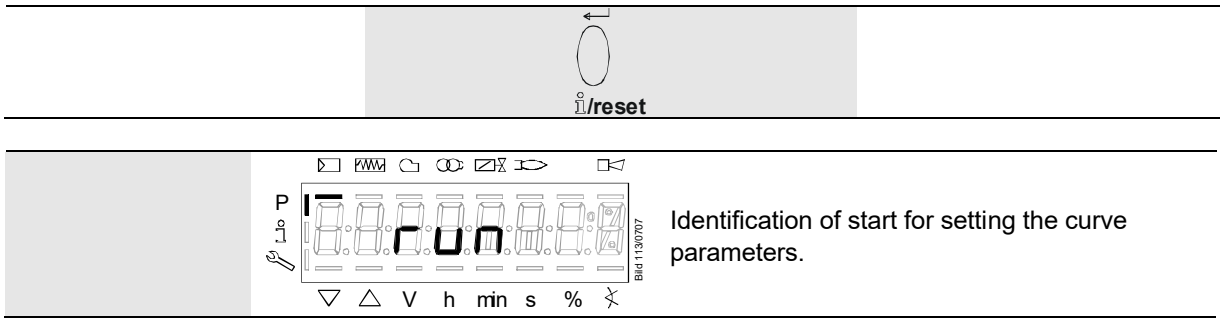

Identification of start for setting the curve parameters.

Example 1 = gas modulating

P0, P1 and P9 are set as described:	Curvepoint	Value 1 fuel	Value 2 air
	P0	30.0	22.0
	P1	32.0	24.0
	P9	80.0	90.0

P2 through P8 have automatically been calculated:	Curvepoint	Value 1 fuel	Value 2 air
	P2	38.0	32.3
	P3	44.0	40.5
	P4	50.0	48.8
	P5	56.0	57
	P6	62.0	65.3
	P7	68.0	73.5
	P8	74.0	81.8

P5 shall now be changed:

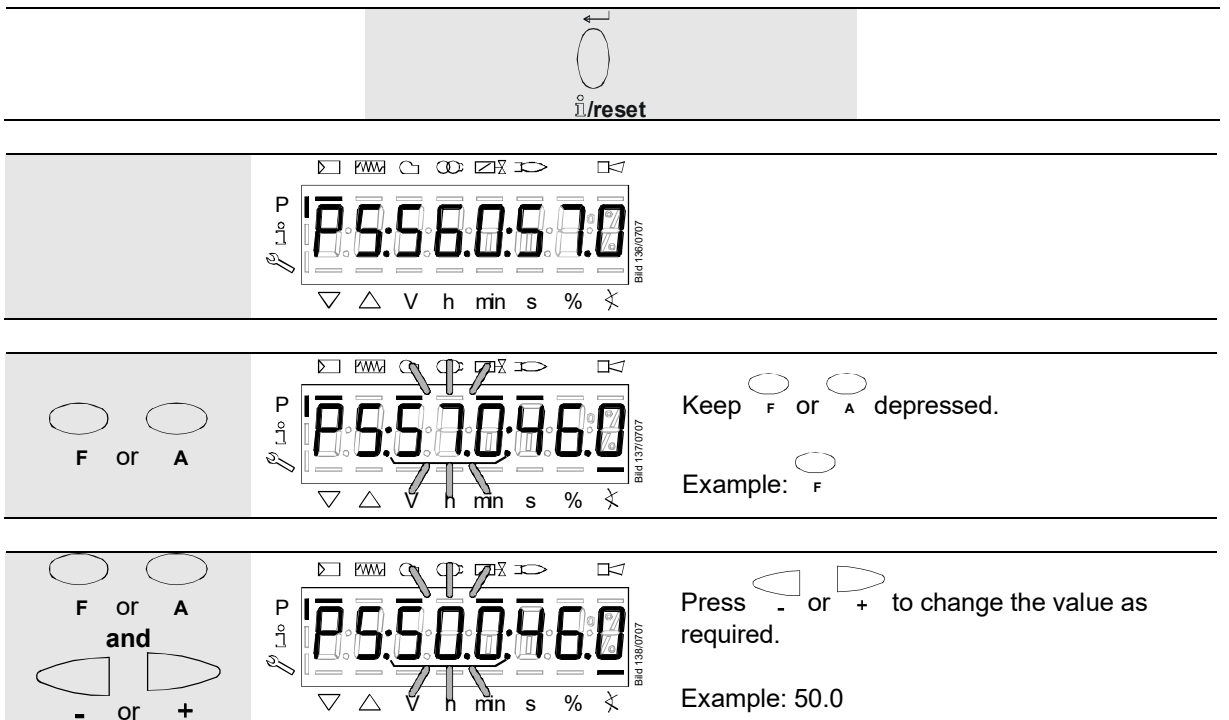

Keep **F** or **A** depressed.

Example: **F**

Press **-** or **+** to change the value as required.

Example: 50.0

Press **-** or **+** to change the value as required.
Example: **00.0**

Release **F** OR **A**.

The required value is adopted.
Example: **P5:50.0:46.0**

Keep **+** depressed for >3 s.

CALC appears.

The display jumps to **P6**.

All curvepoints from **P5** to **P9** have now been automatically recalculated (linear interpolation):

Curvepoint	Value 1 fuel	Value 2 air
P5	50.0	46.0
P6	57.5	57.0
P7	65.0	68.0
P8	72.0	79.0
P9	80.0	90.0

Keep **-** depressed for >3 s.

CALC appears.

The display jumps to **P4**.

All curvepoints from **P1** to **P5** have now been automatically recalculated (linear interpolation):

Curvepoint	Value 1 fuel	Value 2 air
P5	50.0	46.0
P4	45.5	40.0
P3	41.0	35.0
P2	36.5	29.5
P1	32.0	24.0

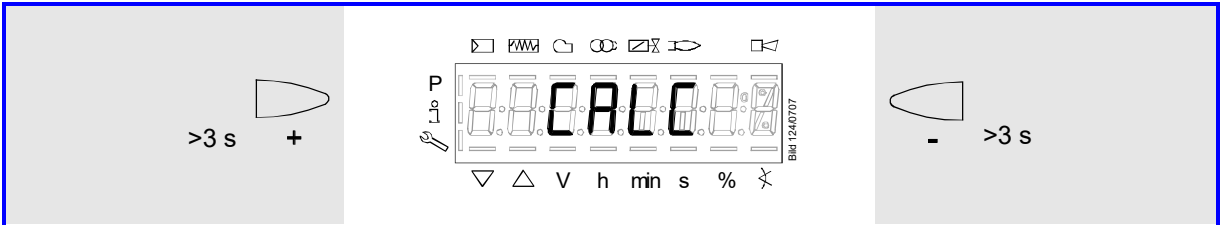

If it is not only the current curvepoint that shall be changed, but all other points in the direction of travel as well, a new straight line from the current point to **P9** (press \oplus) or **P1** (press \ominus) can be calculated by a long push on \ominus or \oplus .

Display **CALC**

Example of presentation

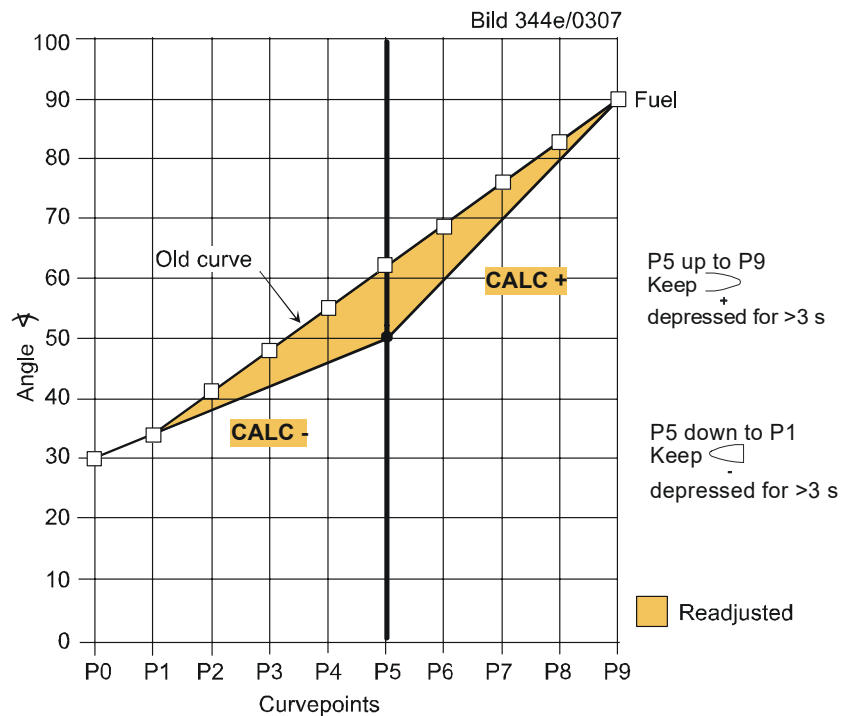

Figure 105: Changing several curvepoints



Note

Due to interpolation, a number of curvepoints change. The curvepoints changed must be approached while using the warm settings to be able to make a check on the burner. If these points have not yet been completely approached, the normal display of the AZL2 shows **OFF UPr**.

27.11.10 Setting of curvepoints for multistage mode («Lo 2-stage» and «Lo 3-stage»)

Example of «Lo 2-stage»

		<p>P0 appears blinking. Curvepoint for ignition load.</p>
		<p>Keep A depressed. You are now at P0 of air actuator A.</p>
		<p>Press simultaneously A and - or + to adjust ignition position P0 of the air actuator. Example: 20.0</p>
		<p>Keep F and A depressed. You are now at n0 of the VSD.</p>
		<p>Press simultaneously F and A and - or + to adjust speed n0 of the VSD. Example: 20.0</p>
		<p>Now, release A. The selected value is adopted. Example: 20.0</p>
		<p>Identification of start for setting the curve parameters.</p>



Note!

You now have the option of pressing /reset to proceed with the warm settings (see section *Warm settings for modulating operation* «G mod», «Gp1 mod», «Gp2 mod»

and «Lo mod») or pressing **-** **+** to proceed with the cold settings (see section *Cold settings for* «G mod», «Gp1 mod», «Gp2 mod» and «Lo mod») of the LMV37.4.

27.11.11 Warm settings for «Lo 2-stage» and «Lo 3-stage»

		<p>Identification of start for setting the curve parameters.</p>
		<p>Provided the load controller is enabled!</p>
		<p>Phase <i>Standby</i> (stationary)</p>
		<p>Phase <i>Fan ramp up</i> (fan motor = ON, safety valve = ON)</p>
		<p>Phase <i>Traveling to prepurge position</i></p>
		<p>Phase <i>Prepurging</i></p>
		<p>Phase <i>Traveling to ignition position</i></p>

Wait until the burner is operating and symbol ▲ or ▼ is no longer highlighted! The startup sequence stops in phase 36 *Traveling to ignition position*. The ignition point can be adjusted under cold conditions.

<p>A and - or + as well as F and A</p>		<p>Ignition position P0 can be set only when symbol ▲ or ▼ is no longer highlighted.</p> <p>Keep A depressed and, for VSD F and A.</p> <p>Press - or + to adjust the value.</p> <p>When symbol ▲ or ▼ is no longer highlighted, the next curvepoint P1 can be selected with +.</p>
--	--	--











A
and

- or +
as well as

F and A
and

- or +



Ignition position **P0** can be set only when symbol ▲ or ▼ is no longer highlighted.

Keep **A** depressed and, for VSD **F** and **A**.

Press **-** or **+** to adjust the value.

When symbol ▲ or ▼ is no longer highlighted, the next curvepoint **P1** can be selected with **+**.



A
and

- or +
as well as

F and A
and

- or +



Low-fire position **P1** can be set only when symbol ▲ or ▼ is no longer highlighted.

Set stage 1 **P1**.

Fuel valve **V1** is switched on.

Keep **A** depressed and, for VSD **F** and **A**.

Press **-** or **+** to adjust the value.

When symbol ▲ or ▼ is no longer highlighted, the next curvepoint **P2on** can be selected with **+**.

To the next curvepoint



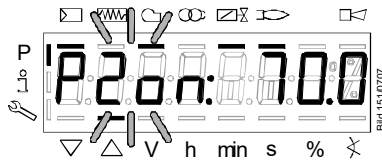
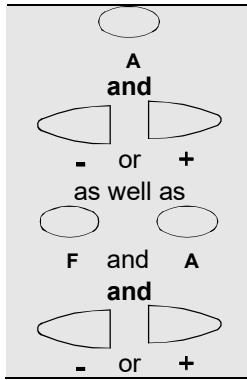

Curvepoint **P2on** can be set only when symbol ▲ or ▼ is no longer highlighted. Set switch-on point stage 2 **P2**. Fuel valve **V2** is still off.

Keep **A** depressed and, for VSD **F** and **A**. Adjust the value with - or +. When symbol ▲ or ▼ is no longer highlighted, the next curvepoint **P2_d** can be selected with +.

To the next curvepoint



Back to the previous curvepoint

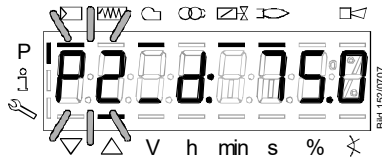
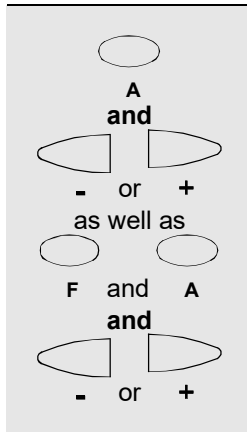

Curvepoint **P2_d** can be set only when symbol ▲ or ▼ is no longer highlighted. Fuel valve **V2** is still off and the LMV37.4 remains at curvepoint **P2on**. Presetting of operating stage **P2** with no travel, aimed at cutting the operating time if there is shortage of air.

Keep **A** depressed and, for VSD **F** and **A**. Press - or + to adjust the value. When symbol ▲ or ▼ is no longer highlighted, the next curvepoint **P2** can be selected with -.

To the next curvepoint



Back to the previous curvepoint

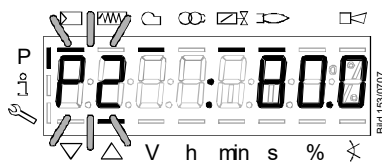
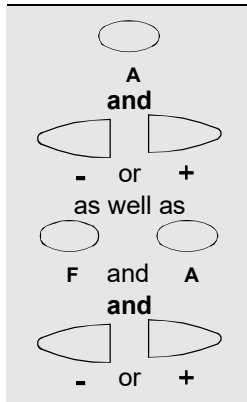

Curvepoint **P2** can only be adjusted when symbol ▲ or ▼ is no longer highlighted.

Fuel valve **V2** is switched on.

Keep **A** depressed and, for VSD **F** and **A**. Press - or + to adjust the value.

When symbol ▲ or ▼ is no longer highlighted, the next curvepoint **P2of** can be selected with -.



Back to the previous curvepoint

Curvepoint **P2of** is now adjusted.

The LMV37.4 remains at P2.

Adjust the switch-off point with no travel.

Now, the point is approached dynamically when traveling from **P2** to **P1**.

When symbol ▲ or ▼ is no longer highlighted, the next curvepoint **P1** can be selected with  .

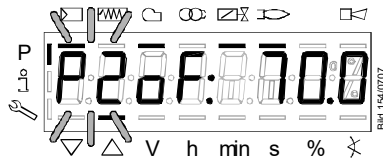

To the next curvepoint



Back to the previous curvepoint

Automatic mode is released when, after reaching **P1**, the curve settings are quit with **ESC**.

If the settings are aborted earlier (**ESC** or shutdown due to fault), start prevention **OFF UPr** is still active until all points are set.

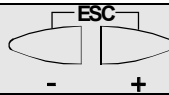
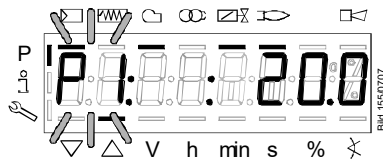

When symbol ▲ or ▼ is no longer highlighted, **ESC** can be pressed a second time.

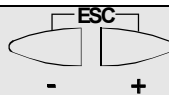
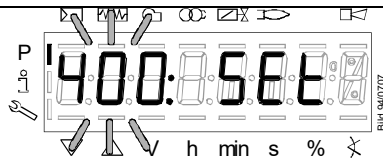

The warm settings for fuel-air ratio control of the LMV37.4 have now been configured.

27.11.12 Cold settings for multistage mode («Lo 2-stage» and «Lo 3-stage»)



Note

Refer to chapters *Warm settings for «Lo 2-stage» and «Lo 3-stage»!*
But with no flame, no actuator travel and no automatic operation after the settings have been made.

If **run** is shown in the display, the following must be observed:

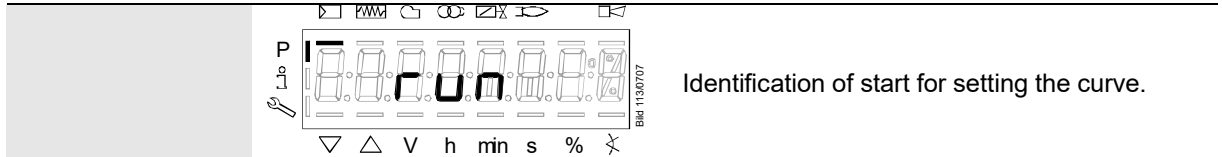

Note!

You now have the option of pressing  - + to continue with the cold setting for the LMV37.4.

27.11.13 Intensity of flame during curve settings

When setting the curve and the curvepoint is displayed, you can press  to show the intensity of flame. When pressing the button for >1 s, a change to parameter 954 is made; when releasing the button, you return to the curvepoint.

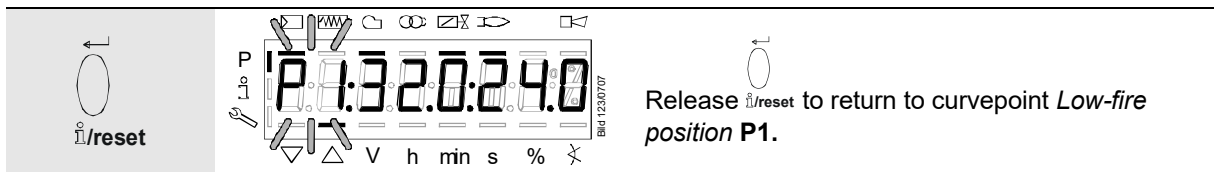
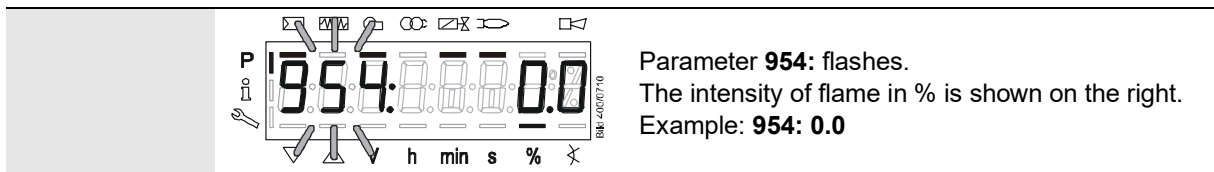
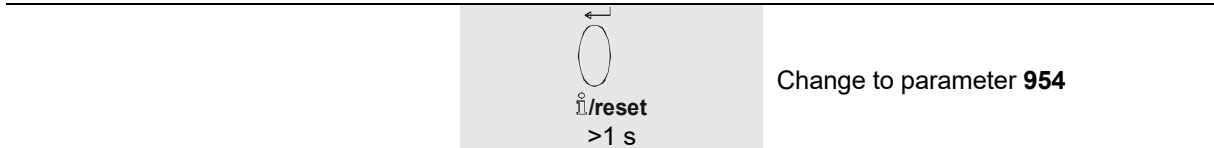
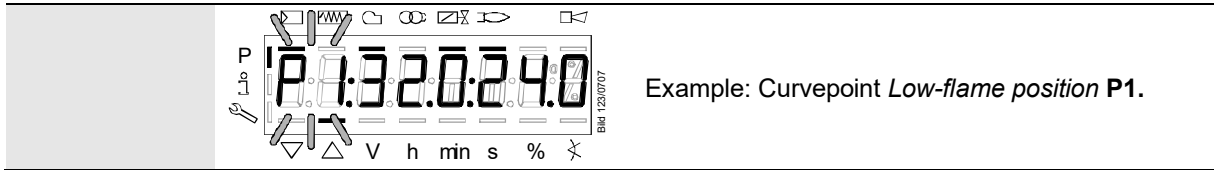

28 Parameter list LMV37.4

Abbreviations for password level:

GA	Building automation
HF	Heating engineer
HF (GA)	Heating engineer (building automation)
IS	Info / service
OEM	Manufacturer of the individual product

Par. no.	Parameter	Number of elements	Type	Edit	Value range		Increment	Default setting	Password level	
					Min.	Max.			write	read
000	Internal parameters									
041	Password heating engineer (HF) (4 characters)	1	Std_u16	Edit	0	65535	1		OEM	OEM
042	OEM password (5 characters)	1	Std_u16	Edit	0	65535	1		OEM	OEM
050	Backup / Restore via AZL2 / PC software ACS410 starting (parameterizing on 1) Index 0 = store backup Index 1 = start restore Error diagnostic via negative value (refer to error code 137)	2	Std_s8	Edit	-99	50	1	0; 0	HF	HF
055	Burner ID of AZL2 backup data record	1	Std_s32	Read only	0	99999999	1	0	---	HF
056	ASN summary of AZL2 backup data record	8	Std_u8	Read only	0	127	1	0	---	HF
057	Software version when setting the AZL2 backup data record	1	Hex_16	Read only	0x100	0xFFFF9	1	0	---	HF
100	General									
102	Identification date	1	Datum	read only	0	255	1		---	IS
103	Identification number	1	Std_u16	read only	0	65535	1		---	IS
104	Preselected parameter set: Customer code	1	Std_u8	read only	0	255	1	9	---	IS
105	Preselected parameter set: Version	1	Hex_16	read only	0	0xFFFF	1	LMV37.400Ax: V 01.06 LMV37.420Ax: V 01.07	---	IS
107	Software version	1	Hex_16	read only	0x100	0xFFFF9	1	V 03.70	---	IS
108	Software variant	1	Std_u8	read only	0	255	1	LMV37.400Ax: 1 LMV37.420Ax: 2	---	IS
111	ASN summary for verification with AZL2 backup data restore	8	Std_u8	read only	0	127	1	0	---	HF
113	Burner identification	1	Std_s32	edit	0	99999999	1	Undefined	HF	IS

Par. no.	Parameter	Number of elements	Type	Edit	Value range		Increment	Default setting		Password level	
					Min.	Max.		write	read		
121	Manual output Undefined = automatic mode	1	Output	edit/clear	0%	100%	0,1%	Undefined		IS	IS
123	Minimum output positioning step Index 0 = output building automation Index 1 = output external load controller analog Index 2 = Power of external load controller contacts	3	Output	edit	0%	100%	0,1%	Index 0 1 2	Wert 0% 1% 0%	HF	HF
124	Loss of flame test (TÜV test) starting (parameterized on 1) (switch off the fuel valves → loss of flame) Error diagnostic via negative value (refer to error code 150)	1	Std_s8	edit	-6	1	1	0		HF	HF
125	Mains frequency 0 = 50 Hz 1 = 60 Hz	1	Selection	edit	0	1	1	LMV37.400Ax: 0 LMV37.420Ax: 1		HF	HF
126	Display brightness	1	Std_u8	edit	0%	100%	1%	LMV37.400Ax: 75% LMV37.420Ax: 100%		HF	HF
127	Timeout for menu operation	1	Std_u8	edit	10 min	120 min	1 min	LMV37.400Ax: 30 min LMV37.420Ax: 60 min		OEM	HF
128	Fuel meter: Pulse valency [pulses / volume unit]	1	Std_u16	edit	0	400	0,01	0		HF	HF
130	Delete display of error history To delete the display: Set parameter to 1, then to 2 Return value 0: Job successfully completed Return value -1: Timeout of 1_2 sequence	1	Std_s8	edit	-5	2	1	0		HF	HF
133	Default output at TÜV test Invalid = TÜV test at active output 20...100 = low-fire...high-fire or stage 1 / stage 2 / stage 3 P1...P3 = stage 1...stage 3	1	Output	edit / clear	20%	100%	0,1%	undefined		HF	HF
141	Operating mode building automation system 0 = off 1 = Modbus 2 = reserved	1	Selection	edit	0	2	1	0		HF	HF
142	Setback time in the event of communication breakdown Setting value: 0 = deactivated	1	Std_u16	edit	0 s	7200 s	1 s	120 s		HF (GA)	HF (GA)

Par. no.	Parameter	Number of elements	Type	Edit	Value range		Increment	Default setting	Password level	
					Min.	Max.			write	read
	1...7200 s									
143	Reserved	1	Std_u8	edit	1	8	1	1	IS	IS
144	Reserved	1	Std_u16	edit	10 s	60 s	1 s	30 s	HF	HF
145	Device address for Modbus of LMV37.4 Setting value: 1...247	1	Std_u8	edit	1	247	1	1	HF	HF
146	Setting of Baud rate for Modbus communication 0 = 9600 1 = 19200	1	Selection	edit	0	1	1	1	HF	HF
147	Setting of parity for Modbus communication 0 = none 1 = odd 2 = even	1	Selection	edit	0	2	1	0	HF	HF
148	Default output if communication with building automation is interrupted Setting values For modulation operation the setting range is as follows: 0...19.9 = burner off 20...100 = 20...100% burner rating (20 = low-fire position) For multistage operation apply to setting range: 0 = burner OFF P1...P3 = stage 1...stage 3 Default setting: <i>Invalid</i>	1	Output	edit/ clear	0%	100%	0,1%	undefined	HF (GA)	HF (GA)
161	Number of faults	1	Std_u16	read only	0	65535	1	0	---	IS
162	Operating hours resettable	1	Std_s32	resettable	0 h	9999999 h	1 h	0 h	IS	IS
163	Operating hours when LMV37.4 is live	1	Std_s32	read only	0 h	9999999 h	1 h	0 h	---	IS
164	Number of startups resettable	1	Std_s32	resettable	0	9999999	1	0	IS	IS
166	Total number of startups	1	Std_s32	read only	0	9999999	1	0	---	IS
167	Fuel volume resettable [m ³ , l, ft ³ , gal]	1	Std_s32	resettable	0	99999999	1	0	IS	IS
176	<i>Switching back to pilot</i> switching cycles	1	Std_s32	read only	0	9999999	1	0	---	IS
186	Software drop out delay time of flame signal (100 ms)	2	Std_u8	edit	0	LMV37.400Ax: 20	1	0; 0	OEM	OEM

Par. no.	Parameter	Number of elements	Type	Edit	Value range		Increment	Default setting	Password level	
					Min.	Max.			write	read
	Index 0 = QRB / QRC (0 = deactivated, >1 = activated) Index 1 = ION / QRA (0 = deactivated, >3 = activated) (only 200 ms-steps)					LMV37.420Ax: 30				
190	Postpurging in lockout position 0 = deactivate (no-load position) 1 = active (postpurge position) When active, the <i>Alarm in the event of start prevention</i> function is only possible to a limited extent!	1	Selection	edit	0	1	1	0	HF	HF
191	Function <i>Switching back to pilot</i> 0 = deactivate 1 = active (low active) 2 = active (high active) Load controller contacts X5-03 are deactivated when function is active!	1	Std_u8	edit	0	2	1	0	OEM	HF
192	<i>Switching back to pilot</i> minimum time	1	Time	edit	5 s	120 s	0,2 s	30 s	HF	HF
193	<i>Switching back to pilot</i> maximum time	1	Time	edit	30 s	108 min	0,2 s	60 min	HF	HF
194	Restart limit value: No flame at end of safety time 1 = no restart 2...4 = 1...3 restarts Recharging time: Entering into operation	1	Std_u8	edit	1	4	1	1	OEM	OEM
195	Restart limit value: Heavy oil direct start 1 = no restart 2...15 = 1...14 restarts 16 = continuous restart Recharging time: At end of shutdown	1	Std_u8	edit	1	16	1	LMV37.400Ax: 3 LMV37.420Ax: 1	HF	HF
196	Restart limit value: Air pressure failure 1 = no restart 2 = 1 restart 3 = 2 restarts	1	Std_u8	edit	1	2	1	1	OEM	OEM

Par. no.	Parameter	Number of elements	Type	Edit	Value range		Increment	Default setting	Password level	
					Min.	Max.			write	read
	Recharging time: At end of shutdown / 24 hours of continuous operation									
197	Setting the flame signal sensitivity of the ionization probe / QRA 0 = standard 1 = approx. twice as high sensitivity	1	Std_u8	edit	0	1	1	0	OEM	HF
198	Maximum output for high flame sensitivity 2 = no maximum output for high flame sensitivity 3...9 = deactivation of the high flame sensitivity from the curvepoint P3...P9	1	Std_u8	edit	2	9	1	4	OEM	HF
199	Restart limit value: Actuators 1 = no restart 2 = 1 restart 3 = 2 restarts Recharging time: End of shutdown and after 24 hours of continuous operation	1	Std_u8	edit	1	3	1	3	OEM	OEM
200	Basic unit LMV37.4									
201	Burner operating mode (fuel train, modulating / multistage, actuators, etc.) -- = undefined (delete curves) 1 = G mod 2 = Gp1 mod 3 = Gp2 mod 4 = Lo mod 5 = Lo 2-stage 6 = Lo 3-stage 7 = G mod pneu 8 = Gp1 mod pneu 9 = Gp2 mod pneu 10 = LoGp mod 11 = LoGp 2-stage 12 = Lo mod 2 fuel valves 13 = LoGp mod 2 fuel valves 14 = G mod pneu without actuator	1	Selection	edit/ clear	1	29	1	undefined	HF	HF (GA)

Par. no.	Parameter	Number of elements	Type	Edit	Value range		Increment	Default setting	Password level	
					Min.	Max.			write	read
	15 = Gp1 mod pneu without actuator 16 = Gp2 mod pneu without actuator 17 = Lo 2-stage without actuator 18 = Lo 3-stage without actuator 19 = G mod gas actuator only 20 = Gp1 mod gas actuator only 21 = Gp2 mod gas actuator only 22 = Lo mod oil actuator only 23 = Ho mod separate circulation control 24 = Ho 2-stage separate circulation control 25 = Ho mod. without circulation control 26 = Ho 2-stage without circulation control 27 = Ho 3-stage without circulation control 28 = G mod mech air actuator only 29 = Gp2 mod mech air actuator only									
204	Behavior if analog input is invalid (4...20 mA) 0 = deactivate default output low-fire / trim function (with warning message) 1 = safety shutdown + startup prevention 2 = deactivate default output low-fire / trim function (without warning message)	1	Std_u8	edit	0	2	1	1	HF	HF
205	Function <i>Load controller contacts staged</i> 0 = standard 1 = stages interchanged	1	Std_u8	edit	0	1	1	0	OEM	OEM
208	Program stop 0 = deactivated 1 = prepurge position (phase 24) 2 = ignition position (phase 36) 3 = interval 1 (phase 44) 4 = interval 2 (phase 52)	1	Selection	edit	0	4	1	0	HF (GA)	HF (GA)
210	Alarm in the event of start prevention 0 = deactivated 1 = activated	1	Selection	edit	0	1	1	LMV37.400Ax: 0 LMV37.420Ax: 1	HF	HF
211	Fan ramp up time	1	Time	edit	2 s	60 s	0,2 s	2 s	HF	HF
212	Maximum time down to low-fire	1	Time	edit	0,2 s	10 min	0,2 s	45 s	HF	HF
213	Waiting time home run	1	Time	edit	2 s	60 s	0,2 s	2 s	OEM	OEM
214	Maximum time start release	1	Time	edit	0,2 s	10 min	0,2 s	LMV37.400Ax: 25 s LMV37.420Ax: 35 s	OEM	OEM

Par. no.	Parameter	Number of elements	Type	Edit	Value range		Increment	Default setting	Password level	
					Min.	Max.			write	read
215	Restart limit value: Safety loop 1 = no restart 2...15 = 1...14 restarts 16 = continuous restart Recharging time: Every 24 hours	1	Std_u8	edit	1	16	1	LMV37.400Ax: 16 LMV37.420Ax: 1	HF	HF
217	Maximum waiting time for detection of detector or pressure switch signal (e.g. home run, preignition)	1	Time	edit	5 s	10 min	0,2 s	30 s	OEM	OEM
221	Gas: Active detector flame evaluation 0 = QRB / QRC 1 = ION / QRA	1	Selection	edit	0	1	1	1	HF	HF
222	Gas: Prepurging 0 = inactive 1 = active	1	Selection	edit	0	1	1	1	HF	HF
223	Restart limit value: Gas pressure switch-min 1 = no restart 2...15 = 1...14 restarts 16 = continuous restart Recharging time: After the <i>Operation</i> phase	1	Std_u8	edit	1	16	1	LMV37.400Ax: 16 LMV37.420Ax: 1	HF	HF
225	Gas: Prepurge time	1	Time	edit	LMV37.400Ax: 20 s LMV37.420Ax: 5 s	60 min	0,2 s	LMV37.400Ax: 20 s LMV37.420Ax: 30 s	HF	HF
226	Gas: Preignition time	1	Time	edit	0,4 s	60 min	0,2 s	3 s	HF	HF
227	Gas: First safety time	1	Time	edit	1 s	10 s	0,2 s	LMV37.400Ax: 3 s LMV37.420Ax: 5 s	OEM	OEM
229	Gas: Time to respond to pressure faults within first and second safety time	1	Time	edit	0,4 s	9,6 s	0,2 s	1,8 s	OEM	OEM
230	Gas: Interval 1	1	Time	edit	0,4 s	60 s	0,2 s	2 s	HF	HF
231	Gas: Second safety time	1	Time	edit	1 s	10 s	0,2 s	LMV37.400Ax: 3 s LMV37.420Ax: 7 s	OEM	OEM
232	Gas: Interval 2	1	Time	edit	0,4 s	60 s	0,2 s	2 s	HF	HF
233	Gas: Afterburn time	1	Time	edit	0,2 s	60 s	0,2 s	8 s	HF	HF
234	Gas: Postpurge time (no extraneous light test)	1	Time	edit	0,2 s	108 min	0,2 s	LMV37.400Ax: 0,2 s LMV37.420Ax: 15 s	HF	HF
235	Gas: Air pressure switch	1	Selection	edit	1	2	1	1	OEM	HF

Par. no.	Parameter	Number of elements	Type	Edit	Value range		Increment	Default setting	Password level	
					Min.	Max.			write	read
	1 = active 2 = active, except phase 60...66 / 70...72 (pneumatic operation only)									
236	Gas: Input pressure switch-min 1 = pressure switch-min before fuel valve V1 (default setting) 2 = valve proving via pressure switch-min (between fuel valve V1 and fuel valve V2) 3 = pressure switch-min after fuel valve V2	1	Selection	edit	1	3	1	1	HF	HF
237	Gas: Input pressure switch-max / POC 1 = pressure switch-max 2 = POC 3 = pressure switch valve proving 4 = additional speed-dependent air pressure switch	1	Selection	edit	1	4	1	LMV37.400Ax: 1 LMV37.420Ax: 2	HF	HF
239	Gas: Forced intermittent operation 0 = inactive 1 = active	1	Selection	edit	0	1	1	1	OEM	HF
240	Restart limit value: Loss of flame 1 = no restart 2 = 1 restart Recharging time: After the <i>Operation</i> phase  Note! Parameters 240 and 280 refer to the same value. This means that no separate setting is possible for oil / gas or fuel 0 / fuel 1.	1	Std_u8	edit	1	2	1	LMV37.400Ax: 2 LMV37.420Ax: 1	OEM	OEM
241	Gas: Execution valve proving 0 = no valve proving 1 = valve proving on startup 2 = valve proving on shutdown 3 = valve proving on startup and shutdown	1	Selection	edit	0	3	1	LMV37.400Ax: 2 LMV37.420Ax: 0	HF	HF
242	Gas: Valve proving - test space evacuating	1	Time	edit	0,2 s	10 s	0,2 s	3 s	OEM	OEM
243	Gas: Valve proving - test time atmospheric pressure	1	Time	edit	0,2 s	60 s	0,2 s	10 s	OEM	OEM
244	Gas: Valve proving - test space filling	1	Time	edit	0,2 s	10 s	0,2 s	3 s	OEM	OEM
245	Gas: Valve proving - test time gas pressure	1	Time	edit	0,2 s	60 s	0,2 s	10 s	OEM	OEM

234/272

Par. no.	Parameter	Number of elements	Type	Edit	Value range		Increment	Default setting	Password level	
					Min.	Max.			write	read
246	Gas: Waiting time gas shortage	1	Time	edit	0,2 s	60 s	0,2 s	10 s	OEM	OEM
248	Gas: Postpurge time (abortion if load controller On)	1	Time	edit	1 s	108 min	0,2 s	1 s	HF	HF
249	LMV37.400Ax Gas: Prepurge time (OEM)	1	Time	edit	5 s	60 min	0,2 s	20 s	OEM	HF
261	Oil: Active detector of flame evaluation 0 = QRB / QRC 1 = ION / QRA	1	Selection	edit	0	1	1	LMV37.400Ax: 0 LMV37.420Ax: 1	HF	HF
262	Oil: Prepurging 0 = inactive 1 = active	1	Selection	edit	0	1	1	1	OEM	OEM
265	Oil: Prepurge time	1	Time	edit	LMV37.400Ax: 15 s LMV37.420Ax: 5 s	60 min	0,2 s	LMV37.400Ax: 15 s LMV37.420Ax: 30 s	HF	HF
266	Oil: Preignition time	1	Time	edit	0,6 s	60 min	0,2 s	2 s	HF	HF
267	Oil: First safety time	1	Time	edit	1 s	15 s	0,2 s	5 s	OEM	OEM
269	Oil: Time to respond to pressure faults within first and second safety time	1	Time	edit	0,4 s	14,6 s	0,2 s	1,8 s	OEM	OEM
270	Oil: Interval 1	1	Time	edit	0,4 s	60 min	0,2 s	2 s	HF	HF
271	Oil: Second safety time	1	Time	edit	1 s	15 s	0,2 s	LMV37.400Ax: 5 s LMV37.420Ax: 10 s	OEM	OEM
272	Oil: Interval 2	1	Time	edit	0,4 s	60 s	0,2 s	2 s	HF	HF
273	Oil: Afterburn time	1	Time	edit	0,2 s	60 s	0,2 s	8 s	HF	HF
274	Oil: Postpurge time (no extraneous light test)	1	Time	edit	0,2 s	108 min	0,2 s	LMV37.400Ax: 0,2 s LMV37.420Ax: 15 s	HF	HF
276	Oil: Input pressure switch-min 1 = active from phase 38 2 = active from safety time	1	Selection	edit	1	2	1	1	HF	HF
277	Oil: Input pressure switch-max/POC 1 = pressure switch-max 2 = POC 3 = not used 4 = additional speed-dependent air pressure switch	1	Selection	edit	1	4	1	1	HF	HF
279	Oil: Forced intermittent operation 0 = inactive 1 = active	1	Selection	edit	0	1	1	1	OEM	HF
280	Restart limit value: Loss of flame 1 = no restart 2 = 1 restart	1	Std_u8	edit	1	2	1	LMV37.400Ax: 2 LMV37.420Ax: 1	OEM	OEM

Par. no.	Parameter	Number of elements	Type	Edit	Value range		Increment	Default setting		Password level	
					Min.	Max.				write	read
	Recharging time: After the <i>Operation</i> phase  Note! Parameters 280 and 380 refer to the same value. This means that no separate setting is possible for oil / gas or fuel 0 / fuel 1.										
281	Oil: Point in time oil is ignited 0 = short preignition (phase 38) 1 = long preignition (with fan) (phase 22)	1	Selection	edit	0	1	1	LMV37.400Ax: 1 LMV37.420Ax: 0		HF	HF
284	Oil: Postpurge time (abortion if load controller ON)	1	Time	edit	1 s	108 min	0,2 s	1 s		HF	HF
286	Oil: Evaluation of heavy oil direct start 0 = only start signal in phase 38 1 = evaluation in phase 38...62	1	Selection	edit	0	1	1	1		HF	HF
287	Oil: Maximum time heavy oil start signal	1	Time	edit	1 s	45 s	0,2 s	45 s		HF	HF
288	LMV37.400Ax Oil: Prepurge time (OEM)	1	Time	edit	5 s	60 min	0,2 s	15 s		OEM	HF
400	Ratio curves										
401	Fuel-air ratio control curves fuel actuator (curve setting only)	13	Std_s16	edit	0°	90°	0,1°	0°; 0°; 15°; undefined		HF	HF
402	Fuel-air ratio control curves air actuator (curve setting only)	13	Std_s16	edit	0°	90°	0,1°	0°; 90°; 45°; undefined		HF	HF
403	Fuel-air ratio control curves VSD (curve setting only)	13	Std_s16	edit	10%	100%	0,1%	0%; 100%; 50%; undefined		HF	HF
500	Fuel-air ratio control										
501	No-flame positions fuel actuator Index 0 = home position Index 1 = prepurge position Index 2 = postpurge position	3	Std_s16	edit	0°	90°	0,1°	Index 0 1 2	Wert 0° 0° 15°	HF	HF
502	No-flame positions air actuator Index 0 = home position Index 1 = prepurge position Index 2 = postpurge position	3	Std_s16	edit	0°	90°	0,1°	Index 0 1 2	Wert 0° 90° 45°	HF	HF

Par. no.	Parameter	Number of elements	Type	Edit	Value range		Increment	Default setting		Password level	
					Min.	Max.		Index	Wert	write	read
503	No-flame speeds VSD Index 0 = no-load speed Index 1 = prepurge speed Index 2 = postpurge speed	3	Std_s16	edit	0%	100%	0,1%	Index 0 1 2	Wert 0% 100% 50%	HF	HF
522	Ramp up	1	Std_u8	edit	5 s	40 s	1 s	10 s		HF	HF
523	Ramp down	1	Std_u8	edit	5 s	40 s	1 s	10 s		HF	HF
529	Separate movement of the PWM fan (ignition speed / postpurge speed) 0 = inactive 1 = active 2 = active (50% tolerance increase outside operation)	1	Std_u8	edit	0	2	1	0		OEM	HF
530	Activation trim function 0 = inactive 1 = active 2 = active (including test function for analog input) 3 = active (including ignition speed) 4 = active (including ignition speed and analog input test)	1	Std_u8	edit	0	4	1	0		OEM	HF
531	Speed change of forced travel	1	Std_u8	edit	1.8%	4%	0.1%	1.8%		OEM	OEM
542	Activation of VSD / PWM fan 0 = deactivated 1 = active 2 = activated (No restart)	1	Selection	edit	0	2	1	0		HF	HF
544	Ramp modulating	1	Std_u8	edit	16 s	80 s	1 s	32 s		HF	HF
545	Lower output limit undefined = 20%	1	Output	edit	20%	100%	0,1%	undefined		HF (GA)	HF (GA)
546	Upper output limit undefined = 100%	1	Output	edit	20%	100%	0,1%	Undefined		HF (GA)	HF (GA)
547	Lower trim limit	1	Std_u16	Edit	-15%	0%	0,1%	-4%		OEM	HF (GA)
548	Upper trim limit	1	Std_u16	edit	0%	25%	0,1%	4%		OEM	HF (GA)
549	Trim damping (based on low-fire)	1	Std_u8	edit	0%	100%	1%	88%		OEM	HF
550	Trim delay time (after entering phase 60)	1	Std_u8	edit	0 s	255%	1 s	25 s		OEM	HF
551	Wait time until warning with active trim limit	1	Time	edit	0 s	60 min	0,2 s	0 s		OEM	HF
552	Behavior if maximum trim limitation time is exceeded 0 = Warning message only (trim impact remains active) 1 = Warning and deactivation of the trim function	1	Std_u8	edit	0	2	1	0		OEM	HF

Par. no.	Parameter	Number of elements	Type	Edit	Value range		Increment	Default setting		Password level	
					Min.	Max.		write	read		
	2 = Shutdown										
600	Actuators										
601	Selection of reference point Index 0 = fuel Index 1 = air Setting values: 0 = CLOSED (<0°) 1 = OPEN (>90°)	2	Selection	edit	0	1	1	Index 0 1	Wert 1 0	OEM	HF
602	Actuator's direction of rotation Index 0 = fuel Index 1 = air Setting values: 0 = counterclockwise 1 = clockwise (exclusively for SQM3)	2	Selection	edit	0	1	1	Index 0 1	Wert 0 0	OEM	HF
606	Tolerance limit of position monitoring [0.1°] Index 0 = fuel Index 1 = air Greatest position error where a fault is securely detected → error detection band: (parameter 606 -0.6°) to parameter 606	2	Std_u8	edit	0,5°	4°	0,1°	Index 0 1	Wert 1,7° 1,7°	OEM	HF
611	Type of reference Index 0 = fuel Index 1 = air Setting values: 0 = standard 1 = range stop in the usable range 2 = internal range stop (SQN1) 3 = both	2	Std_u8	edit	0	3	1	Index 0 1	Wert 0 0	OEM	HF
613	Type of actuator Index 0 = fuel Index 1 = air	2	Std_u8	edit	0	2	1	0; 0		OEM	HF

Par. no.	Parameter	Number of elements	Type	Edit	Value range		Increment	Default setting	Password level	
					Min.	Max.			write	read
	Setting values: 0 = 5 s / 90° (1 Nm, 1,2 Nm, 3 Nm) 1 = 10 s / 90° (6 Nm) 2 = 17 s / 90° (10 Nm)									
641	Activation of the speed standardization of VSD Error diagnostics of negative values (refer to error code 82) 0 = no speed standardization 1 = speed standardization active	1	Std_s8	edit	-25	1	1	0	HF	HF
642	Standardized speed Index 0 = speed 1 Index 1 = speed 2 (internal monitoring) Fuel 1: Index 2 = speed 3 Index 3 = speed 4 (internal monitoring)	4	Std_u16	read only	650	14000	1	Undefined	---	HF
643	Setting the speed signal 0 = asymmetrical 1 = symmetrical	1	Selection	edit	0	1	1	0	OEM	HF
644	Setting pulses per revolution	1	Std_u8	edit	1	6	1	3	OEM	HF
645	Configuration of analog output 0 = DC 0...10 V 1 = DC 2...10 V 2 = DC 0/2...10 V	1	Std_u8	edit	0	2	1	0	HF	
647	No-load time for speed measurement in modulating operation [25 ms]	1	Std_u8	edit	4	8	1	8	OEM	HF
652	VSD behavior when safety loop / burner flange is open 0 = no VSD control when safety loop / burner flange is open 1 = VSD control independent of safety loop / burner flange	1	Std_u8	edit	0	1	1	1	HF	HF
653	VSD standstill supervision in standby mode 0 = deactivate 1 = active	1	Std_u8	edit	0	1	1	1	HF	HF
661	Internal speed control of LMV37.4 0 = deactivated (controlled PWM fan) 1 = activated (VSD)	1	Std_u8	edit	0	1	1	1	OEM	HF

Par. no.	Parameter	Number of elements	Type	Edit	Value range		Increment	Default setting	Password level	
					Min.	Max.			write	read
662	Speed supervision neutral zone	1	Std_u8	edit	0,5%	3,5%	0,1%	0,5%	OEM	HF
663	Speed supervision low deviation zone	1	Std_u8	edit	2%	5,5%	0,1%	2%	OEM	HF
664	Speed supervision: Maximum time outside low deviation zone	1	Time	edit	8 s	16 s	0,2 s	8 s	OEM	HF
665	Speed supervision: Maximum time outside medium deviation zone	1	Time	edit	3 s	7 s	0,2 s	3 s	OEM	HF
667	Minimum prepurge speed	1	Std_s16	edit / clear	40%	100%	0,1%	undefined	OEM	HF
668	Maximum ignition speed	1	Std_s16	edit / clear	20%	75%	0,1%	undefined	OEM	HF
669	Minimum / maximum speed limitation in operation Index 0 = minimum speed Index 1 = maximum speed	2	Std_s16	edit / clear	10%	100%	0,1%	undefined	OEM	HF
670	Speed air pressure switch OFF	1	Std_s16	edit	20%	90%	0,1%	50%	OEM	HF
671	Speed air pressure switch ON	1	Std_s16	edit	45%	100%	0,1%	80%	OEM	HF
700	Error history									
701	Current error state	6								
701.01	Error code	1	Std_u8	read only	0	255	1	0	---	IS
701.02	Diagnostic code	1	Std_u8	read only	0	255	1	0	---	IS
701.03	Error class	1	Std_u8	read only	0	6	1	0	---	IS
701.04	Error phase	1	Std_u8	read only	0	255	1	0	---	IS
701.05	Startup counter	1	Std_s32	read only	0	99999999	1	0	---	IS
701.06	Output	1	Output	read only	0%	100%	0,1%	0%	---	IS
702	Latest error in the history	6								
725	Oldest error in the history	6								
900	Process data									
903	Current output Index 0 = fuel Index 1 = air	2	Output	read only	0%	100%	0,1%	0%	---	IS For query via ACS410
916	Input value analog input 4 mA = -15% 10 mA = 0% 20 mA = 25%	1	Std_s16	read only	-20%	30%	0,1%	0%	---	HF (GA)
917	Target value trim function (with limitation and damping)	1	Std_s16	read only	-17,5%	27,5%	0,1%	0%	---	HF

Par. no.	Parameter	Number of elements	Type	Edit	Value range		Increment	Default setting	Password level	
					Min.	Max.			write	read
918	Current trim correction	1	Std_s16	read only	-17,5%	27,5%	0,1%	0%	---	HF (GA)
922	Incremental position of actuators Index 0 = fuel Index 1 = air	2	Std_s16	read only	-50°	150°	0,01°	0°	---	IS
932	Speed specification of the frequency converter / fan	1	Std_s16	read only	0%	3276,7%	0,1%	0%	---	HF
933	Offset from the VSD speed control	1	Std_s16	read only	-10%	15%	0,1%	0%	---	HF
935	Absolute speed	1	Std_u16	read only	0	65535	0,1	0	---	HF (GA)
936	Standardized speed	1	Std_s16	read only	-200%	200%	0,1%	0%	---	IS
942	Active load controller source 1 = output during curve settings 2 = manual output 3 = default output via building automation 4 = default output via analog input 5 = external load controller via contacts	1	Selection	read only	0	255	1	0	---	HF
947	Result of contact sensing (bit-coded) Bit 0.0 = 1: Pressure switch-min Bit 0.1 = 2: Pressure switch-max Bit 0.2 = 4: Pressure switch valve proving Bit 0.3 = 8 = Air pressure switch Bit 0.4 = 16: Load controller OPEN Bit 0.5 = 32: Load controller ON Bit 0.6 = 64: Load controller CLOSE Bit 0.7 = 128: Safety loop Bit 1.0 = 1: Safety valve Bit 1.1 = 2: Ignition Bit 1.2 = 4: Fuel valve 1 Bit 1.3 = 8: Fuel valve 2 Bit 1.4 = 16: Fuel valve 3 / pilot valve Bit 1.5 = 32: Reset	2	Std_u8	read only	0	255	1	0	---	IS For query via ACS410
948	Contact feedback network counter register	14	Std_u8	read only	0	255	1	0	---	HF
950	Required relay state (bit-coded) Bit 0 = 1: Alarm Bit 1 = 2: Safety valve Bit 2 = 4: Ignition Bit 3 = 8: Fuel valve V1 Bit 4 = 16: Fuel valve V2 Bit 5 = 32: Fuel valve V3 / pilot valve	1	Std_u8	read only	0	255	1	0	---	IS For query via ACS410

Par. no.	Parameter	Number of elements	Type	Edit	Value range		Increment	Default setting	Password level	
					Min.	Max.			write	read
951	Mains voltage (normalized) AC 230 V: Voltage = value x 1.683 AC 120 V: Voltage = value x 0.843	1	Std_u8	read only	0 V	255 V	1 V	0 V	---	HF (GA)
954	Intensity of flame	1	Std_u8	read only	0%	100%	1%	0%	---	IS
960	Actual flow rate (m³/h, l/h, ft³/h, gal/h)	1	Std_u16	read only	0	6553,5	0,1	0	---	IS
961	Phase (state for external module and display)	1	Std_u8	read only	0	255	1	0	---	IS For query via ACS410
981	Error memory: Code	1	Std_u8	read only	0	255	1	0	---	IS For query via ACS410
982	Error memory: Diagnostic code	1	Std_u8	read only	0	255	1	0	---	IS For query via ACS410
992	Error flags	10	Hex_32	resettable	0	0xFFFFFFFF	1	0	HF	HF

Legend

Std_u8 8 bit integer, not signed
Std_u16 16 bit integer, not signed
Std_u32 32 bit integer, not signed
Std_s8 8 bit integer, signed



Note

This data type is also used to mark an invalid or signed values by using the value «-1».

Std_s16 16 Bit integer, signed



Note

This data type is also used to mark an invalid or signed values by using the value «-1».

Std_s32 32 Bit integer, signed



Note



This data type is also used to mark an invalid or signed values by using the value «-1».

29 Error code list (all LMV2 types / LMV3 types)

Error code	Diagnostic code	Meaning for the LMV37.4	Recommended measures or causes
no Comm		No communication between LMV37.4 and AZL2	Check wiring for line interruption/loose contact
2	#	No flame at the end of first safety time	
	1	<i>No flame at the end of first safety time</i>	
	2	<i>No flame at the end of second safety time</i>	
	4	<i>No flame at the end of first safety time (software version \leq V02.00)</i>	
3	#	Air pressure failure	
	0	<i>Air pressure off</i>	
	1	<i>Air pressure on</i>	
	2	<i>Evaluation of air pressure</i>	Correct the setting of parameter 235 or 335 (Deactivation of the air pressure check in operation only allowed in pneumatic operation!)
	4	<i>Air pressure on – prevention of startup</i>	
	20	<i>Air pressure, combustion pressure – start prevention</i>	
	68	<i>Air pressure, POC – start prevention</i>	
	84	<i>Air pressure, combustion pressure, POC – start prevention</i>	
4	#	Extraneous light	
	0	<i>Extraneous light during startup</i>	
	1	<i>Extraneous light during shutdown</i>	
	2	<i>Extraneous light during startup – prevention of startup</i>	
	6	<i>Extraneous light during startup, air pressure – start prevention</i>	
	18	<i>Extraneous light during startup, combustion pressure – start prevention</i>	
	24	<i>Extraneous light during startup, air pressure, combustion pressure – start prevention</i>	
	66	<i>Extraneous light during startup, POC – start prevention</i>	
	70	<i>Extraneous light during startup, air pressure, POC – start prevention</i>	
	82	<i>Extraneous light during startup, combustion pressure, POC – start prevention</i>	
86	<i>Extraneous light during startup, air pressure, combustion pressure, POC – start prevention</i>		
7	#	Loss of flame	
	0	<i>Loss of flame</i>	
	3	<i>Loss of flame (software version \leq V02.00)</i>	

Error code	Diagnostic code	Meaning for the LMV37.4	Recommended measures or causes
	3...255	<i>Loss of flame due to TÜV test (loss-of-flame test)</i>	Diagnostics corresponds to the period of time from shutdown of fuel valves to the detection of loss of flame (increment 0.2 s → Value 5 = 1 s)
12	#	Valve proving	
	0	<i>Fuel valve V1 leaking (fuel valve V2 with valve proving via X5-01)</i>	For valve proving via X5-01 (gas pressure switch-min) <ul style="list-style-type: none"> • Check to see if the valve on the burner side is leaking • Check to see if the pressure switch for the valve proving is closed when gas pressure is present • Check wiring to see if there is a short-circuit
	1	<i>Fuel valve V2 leaking (fuel valve V1 with valve proving via X5-01)</i>	For valve proving via X5-01 (gas pressure switch-min) <ul style="list-style-type: none"> • Check to see if the valve on the gas side is leaking • Check wiring to see if there is a short-circuit
	2	<i>Valve proving not possible</i>	Valve proving activated, but pressure switch-min selected as input function for X9-04 (check parameters 238 and 241)
	3	<i>Valve proving not possible</i>	Valve proving activated, but no input assigned (check parameters 236 and 237)
	4	<i>Valve proving not possible</i>	Valve proving activated, but 2 inputs assigned (set parameter 237 to pressure switch-max or POC)
	5	<i>Valve proving not possible</i>	Valve proving activated, but 2 inputs assigned (check parameters 236 and 237)
	81	<i>V1 leaking</i>	Check to see if the valve on the gas side is leaking Check wiring to see if there is an open-circuit
	83	<i>V2 leaking</i>	Check to see if the valve on the burner side is leaking Check to see if the pressure switch for the leakage test is closed when gas pressure is present Check wiring for short-circuit Check whether the gas pressure is present if the gas pressure switch-min was mounted after the fuel valves.
14	#	POC	
	0	<i>POC open</i>	Check to see if the valve's closing contact is closed
	1	<i>POC closed</i>	Check wiring Check to see if the valve's closing contact opens when valve is controlled
	64	<i>POC open – prevention of startup</i>	Check wiring to see if there is a line interruption. Check to see if the valve's closing contact is closed
18	#	Air pressure fault (speed-dependent air pressure switch)	
	0	<i>Air pressure off</i>	Check the setting for parameter 671. Air pressure switch (X5-02) must report an ON signal above the configured ON threshold.
	1	<i>Air pressure on</i>	Check the setting for parameter 670. Air pressure switch (X5-02) must report an OFF signal below the configured OFF threshold.
	128	<i>Invalid parameterization</i>	Check the setting of the speed thresholds (parameter 671 > 670).
19	80	<i>Combustion pressure, POC – start prevention</i>	Check to see if pressure switch has closed with no combustion pressure present Check wiring for short-circuit

Error code	Diagnostic code	Meaning for the LMV37.4	Recommended measures or causes
20	#	Pressure switch-min	
	0	No minimum gas / oil pressure	Check wiring for line interruption
	1	Gas shortage / prevention of startup	Check wiring for line interruption
21	#	Pressure switch-max / POC	
	0	Pressure switch-max: Max. gas / oil pressure exceeded POC: POC open (software version ≤ V02.00)	Check wiring to see if there is a line interruption. POC: Check to see if the valve's closing contact is closed
	1	POC closed (software version ≤ V02.00)	Check wiring. Check if the valve closure contact opens when valve is controlled.
	64	POC open –prevention of startup (software version ≤ V02.00)	Check wiring. Check if the valve closure contact opens when valve is controlled.
22 OFF S	#	Safety loop / burner flange	
	0	Safety loop / burner flange open	
	1	Safety loop / burner flange open / prevention of startup	
	3	Safety loop/burner flange, extraneous light – start prevention	
	5	Safety loop/burner flange, air pressure – start prevention	
	17	Safety loop/burner flange, combustion pressure – start prevention	
	19	Safety loop/burner flange, extraneous light, combustion pressure – start prevention	
	21	Safety loop/burner flange, air pressure, combustion pressure – start prevention	
	23	Safety loop/burner flange, extraneous light, air pressure, combustion pressure – start prevention	
	65	Safety loop/burner flange, POC – start prevention	
	67	Safety loop/burner flange, extraneous light, POC – start prevention	
	69	Safety loop/burner flange, air pressure, POC – start prevention	
	71	Safety loop/burner flange, extraneous light, air pressure, POC – start prevention	
81	Safety loop/burner flange, combustion pressure, POC – start prevention		
83	Safety loop/burner flange, extraneous light, combustion pressure, POC – start prevention		
85	Safety loop/burner flange, air pressure, combustion pressure, POC – start prevention		
87	Safety loop/burner flange, extraneous light, air pressure, combustion pressure, POC – start prevention		
23	#	Gas pressure switch-min / heavy oil direct start	

Error code	Diagnostic code	Meaning for the LMV37.4	Recommended measures or causes
	0	No minimum gas pressure	Check wiring to see if there is an open-circuit (X5-01)
	1	Gas shortage – start prevention	Check wiring to see if there is an open-circuit (X5-01)
	2	Heavy oil direct start	Check wiring to see if there is an open-circuit (X9-04) Check that the oil is preheated correctly
50	#	Internal error	Make a reset; if error occurs repeatedly, replace the LMV37.4
51	#	Internal error	Make a reset; if error occurs repeatedly, replace the LMV37.4
55	#	Internal error	Make a reset; if error occurs repeatedly, replace the LMV37.4
56	#	Internal error	Make a reset; if error occurs repeatedly, replace the LMV37.4
57	#	Internal error	Make a reset; if error occurs repeatedly, replace the LMV37.4
58	#	Internal error	Make a reset; if error occurs repeatedly, replace the LMV37.4
60	#	Internal error: No valid load controller source	
	0	Internal fault: No valid load controller source	Reset; if error occurs repeatedly, replace the LMV37.4.
	1	Analog output preset valid – prevention of startup	1. Check wiring of analog predefined output to see if there is an open-circuit / loose contact. 2. LMV37.4.520A1: When the trim function is activated (parameter 530), the default output must not be on invalid if the Modbus communication (parameter 148 / 149) is interrupted.
	2	Analog output preset valid – default output low-fire	1. Check wiring of analog predefined output to see if there is an open-circuit / loose contact. 2. LMV37.4.520A1: When the trim function is activated (parameter 530), the default output must not be on invalid if the Modbus communication (parameter 148 / 149) is interrupted.  Note! This information is provided in connection with the thermal shock protection function (manual interruption of 4...20 mA analog input)
61 Fuel Chg	#	Fuel changeover	
Fuel Chg	0	Fuel 0	No error - change to Fuel 0
Fuel Chg	1	Fuel 1	No error - change to Fuel 1
62 Fuel Err	#	Invalid fuel signals / fuel information	
Fuel Err	0	Invalid fuel selection (Fuel 0 + 1 = 0)	Check wiring to see if there is an open-circuit  Note Curves cannot be set
Fuel Err	1	Different fuel selection between the μ Cs	Make a reset; if error occurs repeatedly, replace the LMV37.4
Fuel Err	2	Different fuel signals between the μ Cs	Make a reset; if error occurs repeatedly, replace the LMV37.4
Fuel Err	3	Invalid fuel selection (Fuel 0 + 1 = 1)	Check wiring for short-circuit  Note Curves cannot be set. LMV37.4: Optional press reset button >3 seconds.
65	#	Internal error	Make a reset; if error occurs repeatedly, replace the LMV37.4
66	#	Internal error	Make a reset; if error occurs repeatedly, replace the LMV37.4

246/272

Error code	Diagnostic code	Meaning for the LMV37.4	Recommended measures or causes
67	#	Internal error	Make a reset; if error occurs repeatedly, replace the LMV37.4
70	#	Internal error fuel-air ratio control: Position calculation modulating	
	23	<i>Output invalid</i>	No valid output
	26	<i>Curvepoints undefined</i>	Adjust the curvepoints for all actuators
71	#	Special position undefined	
	0	<i>Home position</i>	Parameterize the home position for all actuators used
	1	<i>Prepurge position</i>	Parameterize the prepurge position for all actuators used
	2	<i>Postpurge position</i>	Parameterize the postpurge position for all actuators used
	3	<i>Ignition position</i>	Parameterize the ignition position for all actuators used
72	#	Internal error fuel-air ratio control	Make a reset; if error occurs repeatedly, replace the LMV37.4
73	#	Internal error fuel-air ratio control: Position calculation multistep	
	23	<i>Output invalid</i>	No valid output
	26	<i>Curvepoints undefined</i>	Adjust the curvepoints for all actuators
75	#	Internal error fuel-air ratio control: Data clocking check	
	1	<i>Current output different</i>	Check the external load controller, including the connection. Parameters 123.1 and 123.2 must be identical (example: set to 1).
	2	<i>Target output different</i>	Check the external load controller, including the connection. Parameters 123.1 and 123.2 must be identical (example: set to 1).
	4	<i>Target positions different</i>	Check the external load controller, including the connection. Parameters 123.1 and 123.2 must be identical (example: set to 1).
	6	<i>Target output and target position different</i>	Check the external load controller, including the connection. Parameters 123.1 and 123.2 must be identical (example: set to 1).
	16	<i>Different positions reached</i>	Can be caused by different standardized speeds (e.g. after restore of data set) when the VSD is activated → standardize again and check adjustment of the fuel-air ratio control system
76	#	Internal error fuel-air control	Make a reset; if error occurs repeatedly, replace the LMV37.4
80	#	Control range limitation of VSD	<p>LMV37.4 could not correct the difference in speed and reached a control range limit.</p> <p>1. LMV37.4 is not standardized for this motor → repeat standardization.</p> <p> Caution! Settings of fuel-air ratio control must be checked!</p> <p>2. Ramp time settings of the VSD are not shorter than those of the LMV37.4 (parameters 522, 523) or the setting for the modulating operating ramp is incorrect (parameter 544)</p> <p>3. Characteristic of the VSD is not linear. Configuration of the voltage input at the VSD must accord with that of the LMV37.4 (parameter 645).</p> <p>4. VSD does not follow quickly enough the changes of the LMV37.4. Check settings of the VSD (input filter, slippage compensation, hiding different speeds)</p>

Error code	Diagnostic code	Meaning for the LMV37.4	Recommended measures or causes
	1	Control range limitation at the bottom	VSD speed was too high
	2	Control range limitation at the top	VSD speed was too low
81	1	Interrupt limitation speed input	Too much electromagnetic interference on the sensor line → improve EMC
82	#	Error during VSD's speed standardization	
	1	Timeout of standardization (VSD ramp down time too long)	Timeout at the end of standardization during ramp down of the VSD → Ramp time settings of the VSD are not shorter than those of the LMV37.4 (parameter: 523)
	2	Storage of standardized speed not successful	Error during storage of the standardized speed → lock the LMV37.4, then reset it and repeat the standardization
	3	Line interruption speed sensor	LMV37.4 receives no pulses from the speed sensor: 1. Motor does not turn. 2. Speed sensor is not connected. 3. Speed sensor is not activated by the sensor disk (check distance)
	4	Speed variation / VSD ramp up time too long / speed below minimum limit for standardization	Motor has not reached a stable speed after ramp up. 1. Ramp time settings of the VSD are not shorter than those of the LMV37.4 (parameters 522, 523). 2. Characteristic of the VSD is not linear. Configuration of the voltage input at the VSD must accord with that of the LMV37.4 (parameter 645). 3. VSD does not follow quickly enough the changes of the LMV37.4. Check settings of the VSD (input filter, slippage compensation, hiding different speeds) 4. Speed of VSD lies below the minimum for standardization (650 1/min)
	5	Wrong direction of rotation	Motor's direction of rotation is wrong. 1. Motor turns indeed in the wrong direction → change parameterization of the direction of rotation or interchange 2 live conductors. 2. Sensor disk is fitted the wrong way → turn the sensor disk.
	6	Unplausible sensor signals	The required pulse pattern (60°, 120°, 180°) has not been correctly identified. 1. Speed sensor does not detect all tappets of the sensor disk → check distance 2. As the motor turns, other metal parts are detected also, in addition to the tappets → improve mounting. 3. Electromagnetic interference on the sensor lines → check cable routing, improve EMC 4. Checking the settings for parameters 643 (symmetry) and 644 (number of pulses per revolution)
	7	Invalid standardized speed	The standardized speed measured does not lie in the permissible range. → Motor turns too slowly or too fast.
	15	Speed deviation $\mu C1 + \mu C2$	The speeds of microcomputer 1 and 2 deviated too much. This can be caused by wrong

248/272

Error code	Diagnostic code	Meaning for the LMV37.4	Recommended measures or causes
			standardized speeds (e.g. after restoring a data set to a new LMV37.4) → repeat standardization and check the fuel-air ratio
	20	<i>Wrong phase of phase manager</i>	Standardization was made in a wrong phase. Permitted are only phases ≤12 → load controller OFF, start standardization again
	21	<i>Safety loop / burner flange open</i>	Safety loop or burner flange is open → repeat standardization with safety loop closed
	22	<i>Air actuator not referenced</i>	Air actuator has not been referenced or has lost its referencing. 1. Check if the reference position can be approached. 2. Check if actuators have been mixed up. 3. If error only occurs after the start of standardization, the actuator might be overloaded and cannot reach its destination.
	23	<i>VSD deactivated</i>	Standardization was started with VSD deactivated → activate the VSD and repeat standardization
	24	<i>No valid operation mode</i>	Standardization was started without valid operation mode → activate valid operation mode and repeat standardization
	25	<i>Pneumatic fuel-air ratio control</i>	Standardization was started with pneumatic fuel-air ratio control → standardization with pneumatic fuel-air ratio control not possible  Attention! If speed supervision is required in the pneumatic fuel-air ratio control, the relevant parameters must be set (parameters 667 / 668 / 669) before standardization.
	128	<i>Running command with no preceding standardization</i>	VSD is controlled but not standardized → make standardization
	255	<i>No standardized speed available</i>	Motor turns but is not standardized → make standardization
83	#	Speed error VSD	Required speed has not been reached
	0	<i>Speed error when trim function is active</i>	Increase parameter 662 (neutral zone in speed supervision) and parameter 663 (close range in speed supervision)
	Bit 0 Valency 1	<i>Lower control range limitation of control</i>	Speed has not been reached because control range limitation has become active → for measures, refer to error code 80
	Bit 1 Valency 2...3	<i>Upper control range limitation of control</i>	Speed has not been reached because control range limitation has become active → for measures, refer to error code 80
	Bit 2 Valency 4...7	<i>Interruption via disturbance pulses</i>	Speed has not been reached due to too much electromagnetic interference on the sensor line → for measures, refer to error code 81
	Bit 3 Valency ≥ 8	<i>Curve too steep in terms of ramp speed</i>	Check speed differential between the curvepoints and the modulating operating ramp setting (parameter 544). 1. Modulating operating ramp 32 seconds Curve slope max. 10% for LMV37.4 ramp of 20 seconds (20% for 10 seconds or 40% for 5

Error code	Diagnostic code	Meaning for the LMV37.4	Recommended measures or causes
			<p>seconds)</p> <ol style="list-style-type: none"> Modulating operating ramp 48 seconds Curve slope max. 10% for LMV37.4 ramp of 30 seconds (20% for 15 seconds or 30% for 10 seconds) Modulating operating ramp 64 seconds Curve slope max. 10% for LMV37.4 ramp of 40 seconds (20% for 20 seconds or 40% for 10 seconds) → Between the ignition point (P0) and the low-fire point (P1), the speed change in modulating mode may be a maximum of 40%, independent of the LMV37.4 ramp. The setting of the VSD ramp must be about 20% faster than the ramps in the LMV37.4 (parameters 522, 523).
	Bit 4 Valency ≥ 16	Interruption of speed signal	<p>No speed detected in spite of control.</p> <ol style="list-style-type: none"> Check if the motor turns. Check if the speed sensor delivers a signal (LED / check distance from the sensor disk). Check wiring of the VSD.
	Bit 5 Valency ≥ 32	Quick shutdown due to excessive speed deviation	<p>Speed deviation was for about 1 s >10% outside the anticipated range.</p> <ol style="list-style-type: none"> Check ramp times of the LMV37.4 and VSD. Check wiring of the VSD.
	Bit 6 Valency ≥ 64	Minimum speed fall below (phase-dependent)	<ol style="list-style-type: none"> Standby (phase 12): Check the setting for the minimum speed and maximum speed during operation (parameter 669.0 / 669.1; MAX > MIN). Check the speed recording (absolute speed parameter 935, standardized speed parameter 936). Prepurge phase (phase 30): Read-in speed or prepurge speed (parameter 503.1 / 506.1) below the minimum speed for prepurging (parameter 667). Operating phases (phase 40...64): Read-in speed or setting of the speed curve below the minimum speed in operation (parameter 669.0).
	Bit 7 Valency ≥ 128	Maximum speed exceeded (phase-dependent)	<ol style="list-style-type: none"> Standby (phase 12): Setting preignition time (parameter gas 226 / 336 or oil 266 / 366) at least 3 seconds (or \geq parameter 665) Standby (phase 12): Check the setting for the minimum speed and maximum speed during operation (parameter 669.0 / 669.1; MAX > MIN). Check the speed recording (absolute speed parameter 935, standardized speed parameter 936). Preignition time (phase 38): Read-in speed or setting of the ignition speed (P0) above the maximum speed for ignition (parameter 668). Operating phases (phase 40...64): Read-in speed or setting of the speed curve above the maximum speed in operation (parameter 669.1).
84	#	Curve slope actuators	
	Bit 0	VSD: Curve too steep in terms of ramp speed	Check speed differential between the curvepoints and the modulating operating ramp setting

Error code	Diagnostic code	Meaning for the LMV37.4	Recommended measures or causes
	<i>Valency 1</i>		(parameter 544). 1. Modulating operating ramp 32 seconds Curve slope max. 10% for LMV37.4 ramp of 20 seconds (20% for 10 seconds or 40% for 5 seconds) 2. Modulating operating ramp 48 seconds Curve slope max. 10% for LMV37.4 ramp of 30 seconds (20% for 15 seconds or 30% for 10 seconds) 3. Modulating operating ramp 64 seconds Curve slope max. 10% for LMV37.4 ramp of 40 seconds (20% for 20 seconds or 40% for 10 seconds) → Between the ignition point (P0) and the low-fire point (P1), the speed change in modulating mode may be a maximum of 40%, independent of the LMV37.4 ramp. 4. Setting of the VSD ramp must be about 20% shorter than the ramps in the LMV37.4 (parameters 522 and 523)
	<i>Bit 1 Valency 2..3</i>	<i>Fuel actuator: Curve too steep in terms of ramp rate</i>	Check position differential between the curvepoints and the modulating operating ramp setting (parameter 544). 1. Modulating operating ramp 32 seconds The slope of the curve may be a maximum position change of 31° (15° for SQM33.6 and 9° for SQM33.7) between 2 curve points in modulating mode. 2. Modulating operating ramp 64 seconds The slope of the curve may be a maximum position change of 62° (30° for SQM33.6 and 18° for SQM33.7) between 2 curve points in modulating mode.
	<i>Bit 2 Valency 4..7</i>	<i>Air actuator: Curve too steep in terms of ramp rate</i>	Check position differential between the curvepoints and the modulating operating ramp setting (parameter 544). 1. Modulating operating ramp 32 seconds The slope of the curve may be a maximum position change of 31° (15° for SQM33.6 and 9° for SQM33.7) between 2 curve points in modulating mode. 2. Modulating operating ramp 64 seconds The slope of the curve may be a maximum position change of 62° (30° for SQM33.6 and 18° for SQM33.7) between 2 curve points in modulating mode.
85	#	Referencing error ones actuators	
	<i>0</i>	<i>Referencing error of fuel actuator</i>	Referencing of fuel actuator not successful. Reference point could not be reached. 1. Check the setting of the actuator type (parameter 613.0 or 614) 2. Check to see if actuators have been mixed up 3. Check to see if actuator is locked or overloaded
	<i>1</i>	<i>Referencing error of air actuator</i>	Referencing of air actuator not successful. Reference point could not be reached.

Error code	Diagnostic code	Meaning for the LMV37.4	Recommended measures or causes
			<ol style="list-style-type: none"> 1. Check the setting of the actuator type (parameter 613.1) 2. Check to see if actuators have been mixed up 3. Check to see if actuator is locked or overloaded
	Bit 7 Valency ≥ 128	Referencing error due to parameter change	Parameterization of an actuator (e.g. the reference position) has been changed. To trigger new referencing, this error is set
86	#	Error fuel actuator	
	0	Position error	Target position could not be reached within the required tolerance band. → Check to see if actuator is locked or overloaded.
	Bit 0 Valency 1	Line interruption	Line interruption detected at actuator's terminals. → Check wiring (voltage X54 across pin 5 or 6 and pin 2 >0.5 V).
	Bit 3 Valency ≥ 8	Curve too steep in terms of ramp rate	Check position differential between the curvepoints and the modulating operating ramp setting (parameter 544). <ol style="list-style-type: none"> 1. Modulating operating ramp 32 seconds The slope of the curve may be a maximum position change of 31° (15° for SQM33.6 and 9° for SQM33.7) between 2 curve points in modulating mode. 2. Modulating operating ramp 64 seconds The slope of the curve may be a maximum position change of 62° (30° for SQM33.6 and 18° for SQM33.7) between 2 curve points in modulating mode.
	Bit 4 Valency ≥ 16	Step deviation in comparison with last referencing	Actuator was overloaded or mechanically twisted. <ol style="list-style-type: none"> 1. Check the setting of the actuator type (parameter 613.0 or 614) 2. Check to see if the actuator is blocked somewhere along its working range. 3. Check to see if the torque is sufficient for the application.
87	#	Error air actuator	
	0	Position error	Target position could not be reached within the required tolerance band. → Check to see if actuator is locked or overloaded.
	Bit 0 Valency 1	Line interruption	Line interruption detected at actuator's terminals. → Check wiring (voltage X53 across pin 5 or 6 and pin 2 >0.5 V).
	Bit 3 Valency ≥ 8	Curve too steep in terms of ramp rate	Check position differential between the curvepoints and the modulating operating ramp setting (parameter 544). <ol style="list-style-type: none"> 1. Modulating operating ramp 32 seconds The slope of the curve may be a maximum position change of 31° (15° for SQM33.6 and 9° for SQM33.7) between 2 curve points in modulating mode. 2. Modulating operating ramp 64 seconds The slope of the curve may be a maximum position change of 62° (30° for SQM33.6 and 18° for SQM33.7) between 2 curve points in modulating mode.
	Bit 4 Valency ≥ 16	Sectional deviation in comparison with last referencing	Actuator was overloaded or mechanically twisted. <ol style="list-style-type: none"> 1. Check the setting of the actuator type (parameter 613.1) 2. Check to see if the actuator is blocked somewhere along its working range.

252/272

Error code	Diagnostic code	Meaning for the LMV37.4	Recommended measures or causes
			3. Check to see if the torque is sufficient for the application.
90	#	Internal error LMV37.4	
91	#	Internal error LMV37.4	
93	#	Error flame signal acquisition	
	3	Short-circuit of sensor	Short-circuit at QRB 1. Check wiring. 2. Flame detector possibly fault.
95	#	Error relay supervision	
	3 Ignition transformer 4 Fuel valve V1 5 Fuel valve V2 6 Fuel valve V3	External power supply NO contact	Check wiring
96	#	Error relay supervision	
	3 Ignition transformer 4 Fuel valve V1 5 Fuel valve V2 6 Fuel valve V3	Relay contacts have welded	Test the contacts: 1. LMV37.4 connected to power: Fan output must be dead. 2. Disconnect power: Disconnect fan. No resistive connection between fan output and neutral conductor allowed. If one of the 2 tests fails, release the LMV37.4 since contact have definitively welded and safety can no longer be ensured.
97	#	Error relay supervision	
	0	Safety relay contacts have welded or external power supply fed to safety relay	Test the contacts: 1. LMV37.4 connected to power: Fan output must be dead. 2. Disconnect power: Disconnect fan. No resistive connection between fan output and neutral conductor allowed. If one of the 2 tests fails, release the LMV37.4 since contacts have definitively welded and safety can no longer be ensured.
98	#	Error relay supervision	
	2 Safety valve 3 Ignition transformer 4 Fuel valve V1 5 Fuel valve V2 6 Fuel valve V3	Relay does not pull in	Make a reset; if error occurs repeatedly, replace the LMV37.4
99	#	Internal error relay control	Make a reset; if error occurs repeatedly, replace the LMV37.4
	3	Internal error relay control	Make a reset. If error occurs repeatedly, replace the LMV37.4 Software version V03.10: If error C:99 D:3 occurs during standardization of the VSD, deactivate temporarily function <i>Alarm in case of start prevention</i> (parameter 210 = 0, when using a release contact) or <i>interrupt</i> the load controller-ON signal
100	#	Internal error relay control	Make a reset; if error occurs repeatedly, replace the LMV37.4

Error code	Diagnostic code	Meaning for the LMV37.4	Recommended measures or causes
105	#	Internal error contact sampling	
	0 Pressure switch-min 1 Pressure switch-max / POC 2 Pressure switch valve proving / Fuel selection Fuel 0 / Reset 3 Air pressure switch 4 Fuel selection Fuel 1 / Load controller OPEN 5 Load controller ON/OFF 6 Fuel selection Fuel 0 / Load controller CLOSED 7 Safety loop / Burner flange 8 Safety valve 9 Ignition transformer 10 Fuel valve V1 11 Fuel valve V2 12 Fuel valve V3 13 Fuel selection Fuel 1 / Reset		Can be caused by capacitive loads or supply of DC voltage to the mains voltage inputs. The diagnostic code indicates the input where the problem occurred
106	#	Internal error contact request	Make a reset; if error occurs repeatedly, replace the LMV37.4
	0 Pressure switch-min 1 Pressure switch-max / POC 2 Pressure switch valve proving / Fuel selection Fuel 0 / Reset 3 Air pressure switch 4 Fuel selection Fuel 1 / Load controller OPEN 5 Load controller ON/OFF 6 Fuel selection Fuel 0 / Load controller CLOSED 7 Safety loop / Burner flange 8 Safety valve 9 Ignition transformer 10 Fuel valve V1 11 Fuel valve V2 12 Fuel valve V3 13 Fuel selection Fuel 1 / Reset		
107	#	Internal error contact request	Make a reset; if error occurs repeatedly, replace the LMV37.4
	0 Pressure switch-min		

Error code	Diagnostic code	Meaning for the LMV37.4	Recommended measures or causes
	1 Pressure switch-max / POC 2 Pressure switch valve proving / Fuel selection Fuel 0 / Reset 3 Air pressure switch 4 Fuel selection Fuel 1 / Load controller OPEN 5 Load controller ON/OFF 6 Fuel selection Fuel 0 / Load controller CLOSED 7 Safety loop / Burner flange 8 Safety valve 9 Ignition transformer 10 Fuel valve V1 11 Fuel valve V2 12 Fuel valve V3 13 Fuel selection Fuel 1 / Reset		
108	#	Internal error contact request	Make a reset; if error occurs repeatedly, replace the LMV37.4
	0 Pressure switch-min 1 Pressure switch-max / POC 2 Pressure switch valve proving / Fuel selection Fuel 0 / Reset 3 Air pressure switch 4 Fuel selection Fuel 1 / Load controller OPEN 5 Load controller ON/OFF 6 Fuel selection Fuel 0 / Load controller CLOSED 7 Safety loop / Burner flange 8 Safety valve 9 Ignition transformer 10 Fuel valve V1 11 Fuel valve V2 12 Fuel valve V3 13 Fuel selection Fuel 1 / Reset		
110	#	Internal error voltage monitor test	Make a reset; if error occurs repeatedly, replace the LMV37.4
111	#	Power failure	Mains voltage to low Exchange ratio diagnostics code → voltage value (120 V: 0.843 / 230 V: 1,683)
112	0	<i>Mains voltage recovery</i>	Error code for triggering a reset on power restoration (no error)

Error code	Diagnostic code	Meaning for the LMV37.4	Recommended measures or causes
113	#	Internal error mains voltage supervision	Make a reset; if error occurs repeatedly, replace the LMV37.4
115	#	Internal error system counter	
116	0	<i>Designed life time exceeded (250'000 startups)</i>	Warning threshold has been reached. The LMV37.4 should be replaced
117	0	<i>Life time exceeded Operation no longer allowed</i>	Switch-off threshold has been reached
120	0	<i>Interrupt limitation fuel meter input</i>	Too many disturbance pulses at the fuel meters input → Improve EMC
121	#	Internal error EEPROM access	Make a reset, repeat last parameterization / check. Restore the parameter set, if error occurs repeatedly, replace the LMV37.4
122	#	Internal error EEPROM access	Make a reset, repeat last parameterization / check. Restore the parameter set, if error occurs repeatedly, replace the LMV37.4
123	#	Internal error EEPROM access	Make a reset, repeat last parameterization / check. Restore the parameter set, if error occurs repeatedly, replace the LMV37.4
124	#	Internal error EEPROM access	Make a reset, repeat last parameterization / check. Restore the parameter set, if error occurs repeatedly, replace the LMV37.4
125	#	Internal error EEPROM read access	Make a reset, repeat last parameterization / check. If error occurs repeatedly, replace the LMV37.4
126	#	Internal error EEPROM write access	Make a reset, repeat last parameterization / check. If error occurs repeatedly, replace the LMV37.4
127	#	Internal error EEPROM access	Make a reset, repeat last parameterization / check. Restore the parameter set, if error occurs repeatedly, replace the LMV37.4
128	0	<i>Internal error EEPROM access - synchronization during initialization</i>	Make a reset; if error occurs repeatedly, replace the LMV37.4
129	#	Internal error EEPROM access – command synchronization	Make a reset, repeat last parameterization / check. If error occurs repeatedly, replace the LMV37.4
130	#	Internal error EEPROM access - timeout	Make a reset, repeat last parameterization / check. If error occurs repeatedly, replace the LMV37.4
131	#	Internal error EEPROM access - page on abort	Make a reset, repeat last parameterization / check. If error occurs repeatedly, replace the LMV37.4
132	#	Internal error EEPROM register initialization	Make a reset; if error occurs repeatedly, replace the LMV37.4
133	#	Internal error EEPROM access – Request synchronization	Make a reset, repeat last parameterization / check. If error occurs repeatedly, replace the LMV37.4
134	#	Internal error EEPROM access – Request synchronization	Make a reset, repeat last parameterization / check. If error occurs repeatedly, replace the LMV37.4
135	#	Internal error EEPROM access – Request synchronization	Make a reset, repeat last parameterization / check. If error occurs repeatedly, replace the LMV37.4
136	#	Restore	
	1	<i>Restore started</i>	Restore of a backup has been started (no error) New LMV37.4 require resetting following restore!
		for further diagnostic codes for error code 136, refer to error code 137	For measures, refer to error code 137
137	#	Internal error – backup / restore	
	157 (-99)	<i>Restore – ok, but backup < data set of current LMV37.4</i>	Restore successful, but backup data record is smaller than in the current LMV37.4
	239 (-17)	<i>Backup – storage of backup in AZL2 faulty</i>	Reset and repeat backup

Error code	Diagnostic code	Meaning for the LMV37.4	Recommended measures or causes
	240 (-16)	Restore – no backup in AZL2	No backup stored in AZL2
	241 (-15)	Restore – abortion due to unsuitable product no. (ASN)	Backup has an unsuitable product no. (ASN) and must not be loaded on the LMV37.4
	242 (-14)	Backup – backup made is inconsistent	Backup is faulty and cannot be transferred back
	243 (-13)	Backup – data comparison between μ Cs faulty	Reset and repeat backup
	244 (-12)	Backup data are incompatible	Backup data are incompatible with the current software version, restore not possible
	245 (-11)	Access error to parameter Restore_Complete	Reset and repeat backup
	246 (-10)	Restore – timeout when storing in EEPROM	Reset and repeat backup
	247 (-9)	Data received are inconsistent	Backup data record invalid, restore not possible
	248 (-8)	Restore cannot at present be made	Reset and repeat backup
	249 (-7)	Restore – abortion due to unsuitable burner identification	Backup has an unsuitable burner identification and must not be transferred to the LMV37.4
	250 (-6)	Backup – CRC of one page is not correct	Backup data record invalid, restore not possible
	251 (-5)	Backup – burner identification is not defined	Define burner identification and repeat backup
	252 (-4)	After restore, pages still on ABORT	Reset and repeat backup
	253 (-3)	Restore cannot at present be made	Reset and repeat backup
	254 (-2)	Abortion due to transmission error	Reset and repeat backup
	255 (-1)	Abortion due to timeout during backup / restore	Make a reset, check the connections and repeat backup / restore In case of repeated backup timeout, the AZL2 does not yet support backup functionality
146	#	Timeout building automation interface	Refer to Modbus User Documentation (A7541)
	1	Modbus timeout	
	2	eBus timeout	
150	#	TÜV test	
	1 (-1)	Invalid phase	TÜV test may only be started in phase 60 (operation)
	2 (-2)	TÜV test default output too low	TÜV test default output must not be smaller than the lower output limit
	3 (-3)	TÜV test default output too high	TÜV test default output must not be greater than the upper output limit
	4 (-4)	Manual interruption	No error: Manual abortion of TÜV test by user
	5 (-5)	TÜV test timeout	No loss of flame after shutdown of fuel valves 1. Check to see if there is extraneous light 2. Check wiring to see if there is a short-circuit 3. Check to see if valve is leaking
154	#	Trim function: Invalid analog value	1. Check wiring of analog trim specification to see if there is an open-circuit / loose contact 2. Check the process date of the read-in trim specification (parameter 916; 4 mA = -15% / 12 mA = 0% / 20 mA = 15%)
	1	Start prevention	
	2	Warning message (trim function temporarily deactivated)	
155	#	Trim function: Invalid curve setting VSD / PWM fan	The curve setting of the VSD / PWM fan must include a reserve for the set trim range. ((Minimum value curve + negative trim range) \leq curve point \leq (maximum value curve - positive trim range))

Error code	Diagnostic code	Meaning for the LMV37.4	Recommended measures or causes
	1..9	<i>Minimum value VSD curve fall below</i>	The curvepoint of the VSD curve is below the permissible minimum value (diagnostic code = curvepoint number, e.g. 1 = P1)
	21..29	<i>Maximum value VSD curve exceeded</i>	The curvepoint of the VSD curve is above the permissible maximum value (diagnostic code = curvepoint number, e.g. 21 = P1)
	41..49	<i>Fuel 1: Minimum value VSD curve fall below</i>	Fuel 1: The curvepoint of the VSD curve is below the permissible minimum value (diagnostic code = curvepoint number, e.g. 41 = P1)
	61..69	<i>Fuel 1: Maximum value VSD curve exceeded</i>	Fuel 1: The curvepoint of the VSD curve is above the permissible maximum value (diagnostic code = curvepoint number, e.g. 61 = P1)
156	#	Trim function: Maximum time for range limit exceeded	 Warning message! Trim function is in limitation for too long (parameter 535; 916 < 531 or 916 > 532). This can be an indication that the trim function or the VSD curve is set incorrectly.
	0	<i>Trim function at lower limit</i>	
	1	<i>Trim function at upper limit</i>	
	10	<i>Fuel 1: Trim function at lower limit</i>	
	11	<i>Fuel 1: Trim function at upper limit</i>	
157	#	Trim function: Analog input test	Test value of the analog input is outside the tolerance range
	0	<i>Analog value standby</i>	<ol style="list-style-type: none"> 1. Check whether a current setting of 12 mA is present in standby. 2. Check parameter 916 (permissible value range -1...+1%).
	1	<i>Analog value prepurging</i>	<ol style="list-style-type: none"> 1. Check whether a current setting of 4 mA is present in prepurging. 2. Check parameter 916 (permissible value range -16...-14%).
165	#	Internal error	
	90	<i>Internal error</i>	Replace LMV37.4 if error occurs constantly.
166	0	<i>Internal error watchdog reset</i>	
167	#	Manual locking	LMV37.4 has been manually locked (no error)
	1	<i>Manual locking by contact</i>	
	2	<i>Manual locking by AZL2</i>	
	3	<i>Manual locking by PC software ACS410</i>	
	8	<i>Manual locking by the AZL2 Timeout / communication breakdown</i>	During a curve adjustment via the AZL2, the timeout for menu operation has elapsed (setting via parameter 127), or communication between the LMV37.4 and the AZL2 has broken down
	9	<i>Manual locking by the PC software ACS410 Communication breakdown</i>	During a curve adjustment via the ACS410, communication between the LMV37.4 and the ACS410 was interrupted for more than 30 seconds
	33	<i>Manual locking by the PC software ACS410 Test of lockout</i>	Via PC software ACS410, a reset attempt was made with an error-free LMV37.4.
168	#	Internal error management	Make a reset; if error occurs repeatedly, replace the LMV37.4
169	#	Internal error management	Make a reset; if error occurs repeatedly, replace the LMV37.4
170	#	Internal error management	Make a reset; if error occurs repeatedly, replace the LMV37.4

258/272

Error code	Diagnostic code	Meaning for the LMV37.4	Recommended measures or causes
171	#	Internal error management	Make a reset; if error occurs repeatedly, replace the LMV37.4
200 OFF	#	LMV37.4 error-free	No error
201 OFF UPr0 or OFF UPr1	#	Prevention of startup	Start prevention due to unparameterized LMV37.4 Go to error history, entry 702, for initial cause of the error with shutdown in connection with the first curve settings
	Bit 0 Valency 1	<i>No operating mode selected</i>	
	Bit 1 Valency 2..3	<i>No fuel train defined</i>	
	Bit 2 Valency 4..7	<i>No curves defined</i>	
	Bit 3 Valency 8..15	<i>Standardized speed undefined</i>	Carry out speed standardization. If no speed signal is present in pneumatic operation, the parameters 667, 668, 669.0 / 669.1 must be set to <i>invalid</i> to switch off the start prevention.
	Bit 4 Valency 16..31	<i>Backup / restore was not possible</i>	
202	#	Internal error operating mode selection	Redefine the operating mode (parameter 201)
203	#	Internal error	Redefine the operating mode (parameter 201). Make a reset; if error occurs repeatedly, replace the LMV37.4
204	Phase number	Program stop	Program stop is active (no error)
205	#	Internal error	Make a reset; if error occurs repeatedly, replace the LMV37.4
206	0	<i>Inadmissible combination of units (LMV37.4 – AZL2)</i>	
207	#	Version compatibility LMV37.4 – AZL2	
	0	<i>LMV37.4 version too old</i>	
	1	<i>AZL2 version too old</i>	
208	#	Internal error	Make a reset; if error occurs repeatedly, replace the LMV37.4
209	#	Internal error	Make a reset; if error occurs repeatedly, replace the LMV37.4
210	0	<i>Selected operation mode is not released for the LMV37.4</i>	Select a released operation mode for the LMV37.4
240	#	Internal error	Make a reset; if error occurs repeatedly, replace the LMV37.4
242	#	Invalid parameterization	
	0	<i>Invalid setting parameter 277</i>	Set parameter 277 to a valid value
	1	<i>Invalid setting parameter 377</i>	Set parameter 377 to a valid value
245	#	Internal error	Make a reset; if error occurs repeatedly, replace the LMV37.4
250	#	Internal error	Make a reset; if error occurs repeatedly, replace the LMV37.4

30 Revision history of LMV37.4

Software changes

Software version V01.20

- Optimizations regarding ACS410 (backup / restore)
- Faster parameterization with AZL2 (3-stage)
- Burner identification setting (entering the password)
- Optimization: LMV37.4 hooks itself up in phase 38
- Optimization: Cold setting via P0 (adoption P0 → P1, correct CALC function)
- Optimization: Delete history (acknowledgement upon completion)
- Prepurging oil – activated / deactivated (parameter 262) for OEM level released
- Setting range of pulse valency fuel meter (parameter 128) increased to 400 pulses per volume unit
- New parameter 645 = configuration analog output

Software version V01.30

- Optimization of phase manager (rectification of error 107)
- Presetting of parameter 281 (time oil ignition) changed to long preignition (with fan)

Software version V01.40

- Optimization: Modbus mode and operating mode are maintained when a reset is made
- Extension: Additional Modbus addresses (refer to Modbus Documentation A7541)
- Extension: Actuator tolerance can be parameterized by OEM and read by the heating engineer
- Change: The heating engineer can set the time when valve proving takes place
- Extension: Calculation of fuel throughput
- Optimization: Plausibility check for continuous operation with ionization amplifier
- Optimization: Separate diagnostic code in the event standardization has not been successful due to an undefined operating mode
- Optimization: Change of password without having to enter the currently valid password
- Extension: Restore of data set possible only when type references of LMV37.4 and data set are identical
- Optimization: Alarm in the event of start prevention after a fixed time of 5 seconds
- Extension: Selection of POC function or *Pressure switch-max*

Software version V01.60

- Optimization: Filtering of analog power output
- Optimization: Plausibility check of ionization amplifier revised

Software version V01.70

Optimization: Final test sequence revised.

Software version V01.80

- Optimization: Valve proving during shutdown after display error in operation
- Optimization: Any valve proving aborted by *Pressure switch-min* during shutdown is repeated with the next startup

Software version V01.90

- Scaling of analog input changed (no *burner OFF* function)
- Optimization: Variable step width between ignition and low-fire (40% difference in speed, independent of ramp time; traveling time varies between 4 and 16 seconds with a 5-second to 20-second ramp)
- Optimization: Checking the standardized speed between microcomputer 1 and microcomputer 2 (wrong standardized speeds after restore)
Objective: Avoiding wrong standardized speeds after restore to new hardware resulting from resonator tolerances of the 2 microcomputers
- Revision of standardization of VSD signal in terms of control and evaluation of errors
- Optimization: Curve adjustment with pneumatic fuel-air ratio control. Here, the curve can be adjusted with no need for making the standardization beforehand of VSD
- Optimization: Parameter access when firing on oil
- Optimization: Assessment of *Pressure switch-min* in phase 62

Software version V2.00

- Correction to fuel train Gp1: First safety time was up to 0.4 seconds too long
- Correction to fuel train Gp1: Evaluation of pressure switches in phases 40 to 50 (*Pressure switch-min* / *Pressure switch-max* were not valued in phase 44, *Pressure switch-min* / *Pressure switch-max* were evaluated in phase 50 although the main valve was switched on)
- First error reception for gas shortage with first setting (gas shortage error was exceeded with first setting of *OFF UPr* – both errors occur in the same cycle)
- Timeout (parameter 127) or communication breakdown with the AZL2 leads to lockout during the time the curves are set (error code: 167, diagnostics: 8)
→ with cold setting, no startup on completion of the password time
- Communication breakdown with the ACS410 (30 seconds) leads to lockout during the time the curves are set (error code: 167, diagnostics 9)

Software version V02.90

- Optimization: Indication of errors on the parameter and info / service menu
- Optimization: Rectification of eBus error telegrams, correction of manufacturer's code for safety temperature limiter, extension of service data query PB:03h SB:10h in order to read out / query the meter readings for the second fuel; the current fuel is output in query PB:05h SB:09h
- Optimization: Curve setting invalid (OFF UPr) upon change to cold settings
- Optimization: Setting of minimum / maximum output via the parameterized output
- Optimization: Shorter startup time with valve proving (prepurge or postpurge time simultaneously with valve proving)
- New function: Loss-of-flame test (TÜV test), forced shutdown of fuel valves
- Extension: Oil pressure switch-min active from phase 38 or safety time (phase 40)
- Extension: Setting of dead band zone for load controller contacts, analog input and building automation system output
- Extension: POC for firing on oil (alternative to pressure switch-max)
- New function: Valve proving via pressure switch-min
- New function: Abortion of postpurging (see postpurge time, extraneous light test in phase 78)
- New function: Evaluation of load controller contacts for multistage operation (normal / interchanged)
- New fuel trains LoGp, Lo-2V, LoGp-2V
- New operating modes (e.g. without actuator)
- New function: Backup / restore via AZL2 (only with new software version AZL2)

Software version V03.00

Optimization: Maximum time of safety phase reduced from 28 to 27 seconds.

Software version V03.10

- Optimization: If power supply fails during the restore process, the data set can be repaired by starting a new restore process (since the backup / restore option is not yet available with V03.00 because there is no suitable AZL2, this effect cannot occur)
- Optimization: When making a reset via the AZL2, an *incomplete* reset occurred in very rare cases (display showed *RESEt*, but reset was not triggered)
- Optimization: The time ascertained by the loss-of-flame test was 0.2 seconds too long
- Optimization: Reduced detection of undervoltage when fan motor is started in phase 22 (when a single-phase motor and the LMV37.4 were powered via the same phase, undervoltage detection could occur on startup; in that case, the LMV37.4 was not operated as specified)
- Optimization: Better overview through text changes of groups 200 = PAr0, 300 = PAr1 and 600 = ACtr on the parameter menu (initially PArA), and hiding of unused parameters after selection of fuel train/operating mode
- Optimization: Control of the fan output during standardization (standby) for using a release contact via an external relay at the fan's output
- Optimization: Curve setting invalid (OFF UPr) after new / further standardization
- Optimization: To shorten the startup time, there is no referencing when postpurging is aborted via load controller ON (direct start)
- Automatic return travel of the SQN1 at the lower internal stop
- Parameter on Siemens level
Longer ignition off time during the first safety time (increased from 0.4 to 0.6 seconds) to prevent wrong error diagnostics in connection with QRA2 (C:7 in place of C:2)

Software version V03.30

- Extension: Display of intensity of flame when setting the curves
- Optimization: Display and diagnostics of changing start preventions
- Optimization: No unplausible relay setpoint (error C:99 D:3) when starting standardization, alarm in case of start prevention and load controller ON signal
- Optimization: No VSD standardization with pneumatic fuel-air ratio control
- Optimization: Referencing in connection with direction of rotation *Right* and home position 90°

Software version V03.40

- Extension: Supports SQM33.6 or SQM33.7
- Extension: Postpurging in the lockout position
- Extension: Heavy oil operating modes
- Optimization: Shutdown of VSD control when burner flange / safety loop is open
- Optimization: Minimum setting for prepurge time: 5 seconds
- Extension: *Switching back to pilot* function
- Optimization: Standstill supervision of the VSD can be switched off in standby mode
- Extension: Restart counter: No flame at the end of safety time, adjustable air pressure failure (OEM), heavy oil direct start (SO))
- Extension: Air pressure supervision in operation with pneumatic fuel-air ratio control can be switched off (OEM)
- Extension: VSD ramp time increased to 40 seconds
- Extension: Modbus data points
127 = Fuel 0 operating mode (parameter 201)
128 = Fuel 1 operating mode (parameter 301)
129 = *Switching back to pilot* cycle counter (parameter 176)

Software version V03.70

- Optimization: No locking with C:75 via asynchronous load controller source
- Extension: Support of PWM fans and symmetrical feedback
- Extension: Increase in the maximum speed to 14000 rpm
- Extension: Additional monitoring of the minimum prepurge speed, maximum ignition speed and minimum speed / maximum speed during operation
- Extension: Increased flexibility when setting the curve (gradient VSD curve)
- Extension: Operating modes for G / Gp2 with mechanical fuel-air ratio control (air actuator only)
- Extension: Trim function for e.g. O2 or temperature
- Extension: Separate phase for running the fan to ignition speed, postpurge speed or standby speed, as well as increased speed tolerance outside operation
- Extension: Speed-dependent air pressure switch
- Extension: Increase in the flame sensitivity
- Extension: Gas pressure switch-min positioned after the fuel valves (CSA 149.3)
- Extension: Immediate lockout in the event of inadequate air supply (UL 795 / EN 676)
- Optimization: No restarts during successive error messages
- Extension: At the end of the speed standardization, the speed must be <10%
- Extension: Modbus data points
 - 140 = fuel 0 operating mode (parameter 201)
 - 141 = fuel 1 operating mode (parameter 301)
 - 142 = meter for function *Revert to Pilot*
 - 144 = lower range limit trim function
 - 145 = upper range limit trim function
 - 146 = lower range limit trim function fuel 1
 - 147 = upper range limit trim function fuel 1
 - 148 = input value analog input trim function
 - 149 = current trim impact
 - 150 = absolute speed
 - 151 = standardized mains voltage (conversion required)

Software version V03.80

- Optimization: Forced travel for very slow PWM fan
- Extension: OEM parameter 531 "Speed change of forced travel"
- Optimization: Trim change only if the speed is within the neutral zone and no forced travel is active
- Optimization: No forced travel for symmetrical speed signal in the "pneumatic modulating ratio control without speed feedback signal" operating mode. Exception: MIN/MAX speed supervision is active
- Optimization: Speed standardization without valid load target possible
- Optimization: If flame sensitivity is high (parameter 197 = 1), the test for extraneous light is also performed with high sensitivity
- Optimization: Error code 168 is no longer generated if a reset is performed during start prevention
- Extension: Parameter 544 "Modulating operating ramp" provided with "16 s" option

31 List of figures

Figure 1: Note on mounting	11
Figure 2: Electrical connection.....	13
Figure 3: Connection interface OCI410 on the BC interface	14
Figure 4: System structure.....	20
Figure 5: Ionization input at AC 120 V / AC 230 V.....	28
Figure 6: Measuring circuit for ionization probe.....	28
Figure 7: Measuring circuit QRA.....	29
Figure 8: QRB1/QRB3 input at AC 230 V.....	30
<i>Figure 9: Measuring circuit QRC</i>	<i>32</i>
Figure 10: Dimension LMV37.4	33
Figure 11: Flame signal input X10-05.....	34
Figure 12: Flame signal input X10-06.....	34
Figure 13: Safety loop X3-04	39
Figure 14: Burner flange X3-03	40
Figure 15: Inputs for external load controller ON / OFF X5-03.....	40
Figure 16: Inputs external load controller Open / Close X5-03.....	40
Figure 17: Air pressure switch X3-02.....	41
Figure 18: Gas pressure switch valve proving X9-04	42
Figure 19: Gas pressure switch-min / oil pressure switch-min X5-01	44
Figure 20: Gas / oil pressure switch-max or POC X5-02.....	47
Figure 21: Additional speed-dependent air pressure switch.....	49
Figure 22: Reset X8-04.....	50
Figure 23: Output alarm X3-05	51
Figure 24: Fan motor contactor X3-05.....	51
Figure 25: Continuous fan operation X3-05.....	51
Figure 26: Output ignition X4-02.....	52
Figure 27: Output fuel valve V1 X8-02.....	53
Figure 28: Output fuel valve V2 X7-01.....	53
Figure 29: Output fuel valve V3 / pilot valve X7-02.....	53
Figure 30: Output safety valve X6-03	53
Figure 31: Output for indication of operation X8-04.....	53
Figure 32: Valve proving with separate	56
Figure 33: Valve proving via gas pressure switch-min	57
Figure 34: Without manual lockout	59
Figure 35: With manual lockout.....	59

Figure 36: Message in the case of program stop.....	66
Figure 37: Continuous fan.....	67
Figure 38: Application example of postpurging in the lockout position with fan but without VSD	69
Figure 39: Application example of postpurging in the lockout position with fan and VSD release contact.....	69
Figure 40: Wiring LMV37.4 with universal controller RWF55.....	71
Figure 41: Switching back to pilot sequence in connection with an RWF55 universal controller	71
Figure 42: Gas direct ignition	72
Figure 43: Gas pilot ignition 1	72
Figure 44: Gas pilot ignition 2	72
Figure 45: Gas – fuel valve control	73
Figure 46: Light oil direct ignition, 1-stage	74
Figure 47: Light oil direct ignition, 2-stage	74
Figure 48: Light oil direct ignition, 3-stage	74
Figure 49: Light oil direct ignition, modulating.....	75
Figure 50: Light oil ignition, modulating	75
Figure 51: Light oil direct ignition - fuel valve control	75
Figure 52: Light oil direct ignition, modulating, without shutdown facility for adjustable head.....	76
Figure 53: Light oil direct ignition, modulating, with shutdown facility for adjustable head	76
Figure 54: Light oil direct ignition – fuel valve control	76
Figure 55: Light oil with gas pilot ignition	77
Figure 56: Light oil with gas pilot ignition – fuel valve control	77
Figure 57: Light oil with gas pilot ignition	78
Figure 58: Light oil with gas pilot ignition – fuel valve control	78
Figure 59: Heavy oil direct ignition, 2-stage, with circulation control	79
Figure 60: Heavy oil direct ignition, modulating, with circulation control.....	79
Figure 61: Heavy oil direct ignition – fuel valve control.....	80
Figure 62: Program for gas direct ignition «G», «G mod», «G mod pneu»	82
Figure 63: Program for gas pilot ignition «Gp1», «Gp1 mod», «Gp1 mod pneu».....	83
Figure 64: Program for gas pilot ignition «Gp2», «Gp2 mod», «Gp2 mod pneu».....	84
Figure 65: Program for light oil direct ignition «Lo», «Lo mod», «Lo 2-stage», «Lo 3- stage»	85
Figure 66: Program light oil pilot ignition «LoGp» «LoGp mod» «LoGp 2 stage».....	86
Figure 67: Program Heavy oil direct ignition «Ho», «Ho mod separate circulation control», «Ho 2-stage separate circulation control».....	87

Figure 68: Program heavy oil direct ignition «Ho», «Ho mod without circulation control», «Ho 2-stage without circulation control», «Ho 3-stage without circulation control»	88
Figure 69: Modulating operation X5-03	95
Figure 70: 2-stage operation X5-03	96
Figure 71: 3-stage operation X5-03	96
Figure 72: Shifting multistage operation (OPEN pin 3 / CLOSE pin 2)	97
Figure 73: External load controller via analog input X64 pin 1 / X64 pin 2	101
Figure 74: Definition of curves	108
Figure 75: Restriction of modulation range	111
Figure 76: Adjustment of output	114
Figure 77: Fuel actuator (X54)	117
Figure 78: Air actuator (X53)	117
Figure 79: Angle definitions with SQM33	121
Figure 80: Direction of rotation (example SQM3)	122
Figure 81: Function principle of VSD	127
Figure 82: Connection of VSD to the LMV37.4	128
Figure 83: Power output	129
Figure 84: Sensor disk	130
Figure 85: Speed sensor	131
Figure 86: Extended speed supervision	135
Figure 87: Setting range trim limits	145
Figure 88: Trim supervision with PLC	148
Figure 89: VSD module X74	150
Figure 90: PWM fan X74	150
Figure 91: PWM fan X64	150
Figure 92: Power output	151
Figure 93: Fuel meter input X75	153
Figure 94: Inputs and outputs	155
Figure 95: Connection via interface COM 92 to superposed systems	156
Figure 96: Communication with display / BC interface (RJ11 jack) (X56)	159
Figure 97: Display input / BC interface (RJ11 jack) X56	159
Figure 98: Description of unit/display and buttons	163
Figure 99: Meaning of display	164
Figure 100: Assignment of levels	177
Figure 101: Info level	178
Figure 102: Service level	183
Figure 103: Structure of parameter levels	194
Figure 104: Setting the curvepoints	212

Index

A

Acquisition of speed	
Fan forced travel	132
Speed extended supervision..	135
ACS410	159
Display / diagnostics.....	34
Actuators	117
Angles definition	117
Direction of rotation	122
Error detection band	125
Forced travel.....	125
Function principle	117
Line interruption detection.....	125
Mixup protection	126
Proposal - implementation ...	126
Monitoring the actuator positions	123
Referencing.....	118
Reference run	120
AZL2	
Backup	167, 168
Burner identification	180
Burner identification entry	189
Buttons description	163
Display / diagnostics.....	34
Display brightness	164
Display description	163
Display of info level.....	178
Display of service level.....	183
Error display	175
Error history.....	184
Error safety shutdown	176
Fault status messages.....	175
Faults number.....	184
Flame intensity	184
Fuel-air ratio curves	204, 217
Flame intensity	226
G mod	207, 209
G mod pneu.....	208, 215
Gp1 mod.....	207, 209
Gp1 mod pneu	208, 215
Gp2 mod.....	207, 209, 215
Gp2 mod pneu	208
Initial commissioning.....	204
Interpolation.....	216
Lo 2-stage.....	220, 221, 225
Lo 3-stage.....	220, 221, 225
Lo mod.....	207, 209
General information	176
Heating engineer's password change.....	191
Identification date.....	179
Identification number.....	179

Index parameter, direct display	199
Info / service mode	175
Info level	178
Info level end	182
Info value display	179
Level assignment	177
LMV37.4 operation	172
Manual control	166
Manual lockout	165
Meaning of symbol	164
Menu operation timeout	166
Menu-driven operation	177
No parameter index, no direct display	197
No parameters index / direct display	195
Normal display	172
OEM's password change	192
Operating	163
Operating position display	174
Parameter index, no direct display	201
Parameter level	186
Parameter level structure	194
Parameter level use	193
Password entry	187
Phase display list	173
Program phase display - running time	172
Program phases display	172
Reset	175
Restore	167, 170
Safety loop	176
Safety notes	162
Service level	183
Service level end	185
Service value display	184
Shutdown display	172
Special functions	165
Standby mode display	172
Startup display	172
Startup number resettable	181
Startup number total	182
Startup prevention	176

B

Burner Identification	156
------------------------------------	-----

C

Connection diagram	155
---------------------------------	-----

D

Digital inputs	
Setting time - pressure switch..	46

X3-02	41	Error history makeup.....	161
X3-03 pin 1 / 2.....	40	F	
X3-04 pin 1 / 2.....	39	Fan control	127
X5-01	44	Connection terminals	150
X5-02	47	PWM fan	150
X5-03 pin 1.....	40	VSD	150
X5-03 pin 2.....	40	Control	141
X5-03 pin 3.....	40	EMC	141
X8-04 pin 1.....	50	Function principle	127
X9-04	42	Parameter settings	136
Digital outputs		PWM fan special conditions ..	141
X3-05 pin 1.....	51	Ramp time	129
X3-05 pin 2.....	51	Safe separation	129
X3-05 pin 3.....	51	Speed acquisition	130
Digital outputs		Hall generator	131
X4-02	52	Proximity switch	130
Digital outputs		Speed control	133
X8-02	53	Speed standardization	137
Digital outputs		Speed supervision	134
X7-01	53	Trim function	144
Digital outputs		External tests	148
X7-02	53	VSD / PWM fan activation	127
Digital outputs		X64 pin 3	128
X6-03	53	X74 pin 3	128
Digital outputs		Flame detector	
X8-04 pin 2	53	Flame detection sensitivity	37
Dimensions	33	Flame detectors	
Display / diagnostics	34	Extraneous light	36
E		Flame intensity	36
Electronic fuel-air ratio control		Loss of flame	35
Curves definition	108	No flame at the end of safety time	3
Home position	105	Supervision	36
Ignition	106	Fuel meter input	153
Max. curve slope	109	Configuration	153
Min. / Max. output	112	Pulses per volume unit	153
Modulating operation	107	Reading	153
Modulation range	111	Resetting	153
Multistage operation	113	Types	153
Curve definition	113	Fuel throughput	154
Modulation range	115	Configuration	154
Operating position	114	Reading out	154
Output adjustment	114	Function description	20
Traveling speed	113	Europe	20
Operating position	110	General information	21
Operating position end	115	North America	20
Outside - operating position ...	105	I	
Postpurging	106	Internal diagram.....	155
Prepurging	106	Ionization probe	
Running position	110	Technical data	27
Setting notes	116	L	
Traveling speed	105, 109	Lifecycle function	161
Electronic ratio control	105	LMV37.4	34
General	105	Cable lengths	25
Error history	160	Connections of actuators	25
Error classes	160		

Cross-sectional areas	25	Special functions	59
Digital inputs	38	Start without prepurging	64
Digital outputs	51	Startup	61
Dimensions	33	Switching back to pilot	70
Error code list	243	Time parameters	54
Flame detectors	35	TÜV test	68
Fuel trains	72	Valve proving	55
Inputs / outputs	34	X5-01	57
Parameter list	227	X9-04	56
Program sequence	54	PWM fan	
Sequence diagrams	81	Acquisition of speed	143
Technical data	22	Characteristics	142
Terminal loading inputs	23	Q	
Terminal loading outputs	23	QRA	
X74 pin 3	25	Technical data	29
Load controller connection	95	QRB	
Emergency operation	104	Technical data	30
Load controller sources	103	QRB4	
Manual control	104	Technical data	31
Manual output	100	QRC	
Output - curve settings	100	Technical data	32
Threshold - modulating operation		S	
.....	101	Safety functions	
Threshold - multistage operation		Restart counter	61
.....	102	Safety notes	10
X5-03 pin 1	95	Commissioning notes	15
X5-03 pin 2	95	Disposal notes	19
X5-03 pin 3	95	Flame detectors	
X64 pin 1	101	Electrical connection	15
X64 pin 2	101	Installation notes	12
X92	98	Life cycle	19
Load output	151	LMV37.4	
2-stage operation	152	Electrical connections	13
3-stage operation	152	Mounting notes	11
Modulating operation	152	Service notes	19
Safe separation	151	Setting notes	17
M		Standards and certificates	18
Make of structure	20	Warning notes	10
O		X56	
Operating mode selection	92	Connection BC interface via	
Deleting curves	94	integrated RJ jack	14
P		Sequence diagram	
Program sequence		Ho, Ho mod separate circulation	
Alarm	60	control, Ho 2-stage separate	
Continuous fan	67	circulation control	87
Forced intermittent operation ..	66	Ho, Ho mod without circulation	
Gas shortage program	65	control, Ho 2-stage without	
Low-fire shutdown	66	circulation control, Ho 3-stage	
Manual lockout	59	without circulation control	88
Phase 00	57	Sequence diagrams	
Phase 01	58	G	82
Postpurging	69	G mod	82
Program stop	66	G mod pneu	82
Reset	59	Gp1	83

Gp1 mod	83	T	
Gp1 mod pneu.....	83	Technical data.....	22
Gp2.....	84	AGV50 from AZL2 to BC interface	
Gp2 mod	84	26
Gp2 mod pneu.....	84	Environmental conditions	26
Lo	85	Flame detectors.....	27
Lo 2-stage.....	85	Trim function	
Lo 3-stage.....	85	Internal check optional	146
Lo mod.....	85	Settings / mode of operation..	145
LoGp	86	Type summary	21
LoGp 2 stage	86	X	
LoGp mod.....	86	X53 / X54.....	117
Superposed system connection..	156	X74 pin 3.....	151
Building automation functions		X75 pin 1.....	153
.....	156	X75 pin 2.....	153
General information.....	156		
Modbus	158		